

Linear Algebra for Team-Based Inquiry Learning

PREVIEW Edition

Linear Algebra for Team-Based Inquiry Learning

PREVIEW Edition

Steven Clontz
University of South Alabama

Drew Lewis

Contributing Authors

Jessalyn Bolkema
California State University, Dominguez Hills

Jeff Ford
Gustavus Adolphus College

Jordan Kostiuk
Brown University

Sharona Krinsky
California State University, Los Angeles

Jennifer Nordstrom
Linfield University

Kate Owens
College of Charleston

September 12, 2024

Website: [Team-Based Inquiry Learning](#)¹

©2021–2024 Steven Clontz and Drew Lewis

This work is freely available for noncommercial use in your classroom, as well as any other purpose allowed by our license at [GitHub.com/TeamBasedInquiryLearning](#)².

¹[tbil.org](#)

²[github.com/TeamBasedInquiryLearning/library/blob/main/LICENSE.md](#)

For Instructors

Features of the text. The book is organized into Modules. You can think of a module as a chapter in a textbook.

In a TBIL course, each module starts with a **Readiness Assurance Process** to check understanding of and solidify prerequisite knowledge (from other courses or previous modules) that will be needed in the upcoming module. The front page for each module provides a list of these Readiness Assurance outcomes, along with study resources and exercise students can use to refresh themselves on this prerequisite knowledge. Readiness Assurance Tests that assess this knowledge are available as part of the TBIL Resource Library (see [TBIL Resource Library](#)). Join the TBIL community (see [Community and Support](#)) to gain access to these.

Within each module there is a varying amount of sections, one per learning outcome. Each section is designed to guide students into being able to demonstrate their understanding of that specific outcome. The learning outcome can be tested with a CheckIt Exercise, which are linked at the end of each section.

Within each section, students engage in Activities, which are interspersed with definitions, theorems, remarks, examples, etc. as needed to guide the learning process. The activities start in an exploratory way then building the concepts on the results of this exploration. The concepts are then practiced with less scaffolding to build fluency. Finally, towards the end of the section we connect the concepts and extend them to new settings.

Each section/learning outcome is designed with an exercise, a specific set of tasks, that the students need to be able to solve to demonstrate their competency. Virtually limitless randomized versions of the exercise can be generated via CheckIt to build a problem bank and allow for reassessment.

Community and Support. If you are adopting this text in your class, please fill out this [short form](#)³ so we can track usage, let you know about updates, etc.

Implementation of these materials is supported by a TBIL community of practice which offers both formal and informal professional development opportunities. The best way to connect with us is on our [Slack workspace](#)⁴.

These materials are a product of our TBIL community. Feedback and suggestions

³forms.gle/Ktfbma6iBn2gN1W78

⁴chat.tbil.org/

for improvements are most welcome, either through our [GitHub Repository](#)⁵ or the [Slack workspace](#)⁶.

⁵github.com/TeamBasedInquiryLearning/library

⁶chat.tbil.org/

Video Resources

Videos are available at the end of each section. A complete playlist of videos aligned with this text is [available on YouTube](#)⁷.

⁷www.youtube.com/watch?v=kpOK7RhFEiQ&list=PLwXCBkIf7xBMo3zMnD7WVt39rANLlSdmj

Contents

For Instructors	v
Video Resources	vii
1 Systems of Linear Equations (LE)	1
1.1 Linear Systems, Vector Equations, and Augmented Matrices (LE1)	2
1.2 Row Reduction of Matrices (LE2)	10
1.3 Counting Solutions for Linear Systems (LE3)	18
1.4 Linear Systems with Infinitely-Many Solutions (LE4)	23
2 Euclidean Vectors (EV)	29
2.1 Linear Combinations (EV1)	30
2.2 Spanning Sets (EV2)	36
2.3 Subspaces (EV3)	42
2.4 Linear Independence (EV4)	51
2.5 Identifying a Basis (EV5)	56
2.6 Subspace Basis and Dimension (EV6)	63
2.7 Homogeneous Linear Systems (EV7)	67
3 Algebraic Properties of Linear Maps (AT)	73
3.1 Linear Transformations (AT1)	74
3.2 Standard Matrices (AT2)	80
3.3 Image and Kernel (AT3)	87
3.4 Injective and Surjective Linear Maps (AT4)	95
3.5 Vector Spaces (AT5)	105
3.6 Polynomial and Matrix Spaces (AT6)	111

4	Matrices (MX)	117
4.1	Matrices and Multiplication (MX1)	118
4.2	The Inverse of a Matrix (MX2)	123
4.3	Solving Systems with Matrix Inverses (MX3)	128
4.4	Row Operations as Matrix Multiplication (MX4)	131
5	Geometric Properties of Linear Maps (GT)	136
5.1	Row Operations and Determinants (GT1)	137
5.2	Computing Determinants (GT2)	152
5.3	Eigenvalues and Characteristic Polynomials (GT3)	157
5.4	Eigenvectors and Eigenspaces (GT4)	162

Appendices

A	Applications	166
A.1	Civil Engineering: Trusses and Struts	166
A.2	Computer Science: PageRank	174
A.3	Geology: Phases and Components	180
B	Appendix	182
B.1	Sample Exercises with Solutions	182
B.2	Definitions	206

Back Matter

Index	209
--------------	------------

Chapter 1

Systems of Linear Equations (LE)

Learning Outcomes

How can we solve systems of linear equations?

By the end of this chapter, you should be able to...

1. Translate back and forth between a system of linear equations, a vector equation, and the corresponding augmented matrix.
2. Explain why a matrix isn't in reduced row echelon form, and put a matrix in reduced row echelon form.
3. Determine the number of solutions for a system of linear equations or a vector equation.
4. Compute the solution set for a system of linear equations or a vector equation with infinitely many solutions.

Readiness Assurance. Before beginning this chapter, you should be able to...

1. Determine if a system to a two-variable system of linear equations will have zero, one, or infinitely-many solutions by graphing.
 - Review: [Khan Academy](#)¹
2. Find the unique solution to a two-variable system of linear equations by back-substitution.
 - Review: [Khan Academy](#)²
3. Describe sets using set-builder notation, and check if an element is a member of a set described by set-builder notation.
 - Review: [YouTube](#)³

¹bit.ly/2l21etm

²www.khanacademy.org/math/algebra-basics/alg-basics-systems-of-equations/alg-basics-solving-systems-with-substitution/v/practice-using-substitution-for-systems

³youtu.be/xnfUZ-NTsCE

1.1 Linear Systems, Vector Equations, and Augmented Matrices (LE1)

Learning Outcomes

- Translate back and forth between a system of linear equations, a vector equation, and the corresponding augmented matrix.

1.1.1 Warm Up

Activity 1.1.1 Consider the pairs of lines described by the equations below. Decide which of these are parallel, identical, or transverse (i.e., intersect in a single point).

(a)

$$\begin{aligned} -x_1 + 3x_2 &= 1 \\ 2x_1 - 5x_2 &= 2 \end{aligned}$$

(b)

$$\begin{aligned} -x_1 + 3x_2 &= 1 \\ 2x_1 - 6x_2 &= -2 \end{aligned}$$

(c)

$$\begin{aligned} -x_1 + 3x_2 &= 1 \\ 2x_1 - 6x_2 &= 3 \end{aligned}$$

1.1.2 Class Activities

Definition 1.1.2 A **matrix** is an $m \times n$ array of real numbers with m rows and n columns:

$$\begin{bmatrix} a_{11} & a_{12} & \cdots & a_{1n} \\ a_{21} & a_{22} & \cdots & a_{2n} \\ \vdots & \vdots & \ddots & \vdots \\ a_{m1} & a_{m2} & \cdots & a_{mn} \end{bmatrix} = [\vec{v}_1 \quad \vec{v}_2 \quad \cdots \quad \vec{v}_n].$$

Frequently we will use matrices to describe an ordered list of its **column vectors**:

$$\begin{bmatrix} a_{11} \\ a_{21} \\ \vdots \\ a_{m1} \end{bmatrix}, \begin{bmatrix} a_{12} \\ a_{22} \\ \vdots \\ a_{m2} \end{bmatrix}, \cdots, \begin{bmatrix} a_{1n} \\ a_{2n} \\ \vdots \\ a_{mn} \end{bmatrix} = \vec{v}_1, \vec{v}_2, \cdots, \vec{v}_n.$$

When order is irrelevant, we will use set notation:

$$\left\{ \begin{bmatrix} a_{11} \\ a_{21} \\ \vdots \\ a_{m1} \end{bmatrix}, \begin{bmatrix} a_{12} \\ a_{22} \\ \vdots \\ a_{m2} \end{bmatrix}, \dots, \begin{bmatrix} a_{1n} \\ a_{2n} \\ \vdots \\ a_{mn} \end{bmatrix} \right\} = \{\vec{v}_1, \vec{v}_2, \dots, \vec{v}_n\}.$$

◇

Definition 1.1.3 A **Euclidean vector** is an ordered list of real numbers

$$\begin{bmatrix} a_1 \\ a_2 \\ \vdots \\ a_n \end{bmatrix}.$$

We will find it useful to almost always typeset Euclidean vectors vertically, but the notation $[a_1 \ a_2 \ \dots \ a_n]^T$ is also valid when vertical typesetting is inconvenient. The set of all Euclidean vectors with n components is denoted as \mathbb{R}^n , and vectors are often described using the notation \vec{v} .

Each number in the list is called a **component**, and we use the following definitions for the sum of two vectors, and the product of a real number and a vector:

$$\begin{bmatrix} a_1 \\ a_2 \\ \vdots \\ a_n \end{bmatrix} + \begin{bmatrix} b_1 \\ b_2 \\ \vdots \\ b_n \end{bmatrix} = \begin{bmatrix} a_1 + b_1 \\ a_2 + b_2 \\ \vdots \\ a_n + b_n \end{bmatrix} \quad c \begin{bmatrix} a_1 \\ a_2 \\ \vdots \\ a_n \end{bmatrix} = \begin{bmatrix} ca_1 \\ ca_2 \\ \vdots \\ ca_n \end{bmatrix}$$

◇

Following are some examples of addition and scalar multiplication in \mathbb{R}^4 .

$$\begin{bmatrix} 3 \\ -3 \\ 0 \\ 4 \end{bmatrix} + \begin{bmatrix} 0 \\ 2 \\ 7 \\ 1 \end{bmatrix} = \begin{bmatrix} 3+0 \\ -3+2 \\ 0+7 \\ 4+1 \end{bmatrix} = \begin{bmatrix} 3 \\ -1 \\ 7 \\ 5 \end{bmatrix}$$

$$-4 \begin{bmatrix} 0 \\ 2 \\ -2 \\ 3 \end{bmatrix} = \begin{bmatrix} -4(0) \\ -4(2) \\ -4(-2) \\ -4(3) \end{bmatrix} = \begin{bmatrix} 0 \\ -8 \\ 8 \\ -12 \end{bmatrix}$$

□

Definition 1.1.5 A **linear equation** is an equation of the variables x_i of the form

$$a_1x_1 + a_2x_2 + \dots + a_nx_n = b.$$

A **solution** for a linear equation is a Euclidean vector

$$\begin{bmatrix} s_1 \\ s_2 \\ \vdots \\ s_n \end{bmatrix}$$

that satisfies

$$a_1s_1 + a_2s_2 + \cdots + a_ns_n = b$$

(that is, a Euclidean vector whose components can be plugged into the equation). \diamond

Remark 1.1.6 In previous classes you likely used the variables x, y, z in equations. However, since this course often deals with equations of four or more variables, we will often write our variables as x_i , and assume $x = x_1, y = x_2, z = x_3, w = x_4$ when convenient.

Definition 1.1.7 A **system of linear equations** (or a **linear system** for short) is a collection of one or more linear equations.

$$\begin{array}{r} a_{11}x_1 + a_{12}x_2 + \cdots + a_{1n}x_n = b_1 \\ a_{21}x_1 + a_{22}x_2 + \cdots + a_{2n}x_n = b_2 \\ \vdots \qquad \qquad \qquad \vdots \qquad \qquad \qquad \vdots \qquad \qquad \qquad \vdots \\ a_{m1}x_1 + a_{m2}x_2 + \cdots + a_{mn}x_n = b_m \end{array}$$

Its **solution set** is given by

$$\left\{ \left[\begin{array}{c} s_1 \\ s_2 \\ \vdots \\ s_n \end{array} \right] \mid \left[\begin{array}{c} s_1 \\ s_2 \\ \vdots \\ s_n \end{array} \right] \text{ is a solution to all equations in the system} \right\}.$$

\diamond

Remark 1.1.8 When variables in a large linear system are missing, we prefer to write the system in one of the following standard forms:

Original linear system:

Verbose standard form:

Concise standard form:

$$\begin{array}{r} x_1 + 3x_3 = 3 \\ 3x_1 - 2x_2 + 4x_3 = 0 \\ -x_2 + x_3 = -2 \end{array} \qquad \begin{array}{r} 1x_1 + 0x_2 + 3x_3 = 3 \\ 3x_1 - 2x_2 + 4x_3 = 0 \\ 0x_1 - 1x_2 + 1x_3 = -2 \end{array} \qquad \begin{array}{r} x_1 \qquad + 3x_3 = 3 \\ 3x_1 - 2x_2 + 4x_3 = 0 \\ -x_2 + x_3 = -2 \end{array}$$

Remark 1.1.9 It will often be convenient to think of a system of equations as a vector equation.

By applying vector operations and equating components, it is straightforward to see that

the vector equation

$$x_1 \begin{bmatrix} 1 \\ 3 \\ 0 \end{bmatrix} + x_2 \begin{bmatrix} 0 \\ -2 \\ -1 \end{bmatrix} + x_3 \begin{bmatrix} 3 \\ 4 \\ 1 \end{bmatrix} = \begin{bmatrix} 3 \\ 0 \\ -2 \end{bmatrix}$$

is equivalent to the system of equations

$$\begin{aligned} x_1 + 3x_3 &= 3 \\ 3x_1 - 2x_2 + 4x_3 &= 0 \\ -x_2 + x_3 &= -2 \end{aligned}$$

Definition 1.1.10 A linear system is **consistent** if its solution set is non-empty (that is, there exists a solution for the system). Otherwise it is **inconsistent**. \diamond

Fact 1.1.11 All linear systems are one of the following:

1. Consistent with one solution: *its solution set contains a single vector, e.g.* $\left\{ \begin{bmatrix} 1 \\ 2 \\ 3 \end{bmatrix} \right\}$
2. Consistent with infinitely-many solutions: *its solution set contains infinitely many vectors, e.g.* $\left\{ \begin{bmatrix} 1 \\ 2 - 3a \\ a \end{bmatrix} \mid a \in \mathbb{R} \right\}$
3. Inconsistent: *its solution set is the empty set, denoted by either $\{\}$ or \emptyset .*

Activity 1.1.12 All inconsistent linear systems contain a logical **contradiction**. Find a contradiction in this system to show that its solution set is the empty set.

$$\begin{aligned} -x_1 + 2x_2 &= 5 \\ 2x_1 - 4x_2 &= 6 \end{aligned}$$

Activity 1.1.13 Consider the following consistent linear system.

$$\begin{aligned} -x_1 + 2x_2 &= -3 \\ 2x_1 - 4x_2 &= 6 \end{aligned}$$

(a) Find several different solutions for this system:

$$\begin{bmatrix} 1 \\ -1 \end{bmatrix} \quad \begin{bmatrix} ? \\ 2 \end{bmatrix} \quad \begin{bmatrix} 0 \\ ? \end{bmatrix} \quad \begin{bmatrix} ? \\ ? \end{bmatrix} \quad \begin{bmatrix} ? \\ ? \end{bmatrix}$$

(b) Suppose we let $x_2 = a$ where a is an arbitrary real number. Which of these expressions for x_1 in terms of a satisfies both equations of the linear system?

- | | |
|----------------|--------------------|
| A. $x_1 = -3a$ | C. $x_1 = 2a - 3$ |
| B. $x_1 = 3$ | D. $x_1 = -4a + 6$ |

(c) Given $x_2 = a$ and the expression you found in the previous task, which of these describes the solution set for this system?

- A. $\left\{ \left[\begin{array}{c} 2a-3 \\ a \end{array} \right] \mid a \in \mathbb{R} \right\}$ C. $\left\{ \left[\begin{array}{c} a \\ b \end{array} \right] \mid a \in \mathbb{R} \right\}$
- B. $\left\{ \left[\begin{array}{c} a \\ 2a-3 \end{array} \right] \mid a \in \mathbb{R} \right\}$ D. $\left\{ \left[\begin{array}{c} 2a-3 \\ 2b-3 \end{array} \right] \mid a \in \mathbb{R} \right\}$

Activity 1.1.14 Consider the following linear system.

$$\begin{aligned} x_1 + 2x_2 - x_4 &= 3 \\ x_3 + 4x_4 &= -2 \end{aligned}$$

Substitute $x_2 = a$ and $x_4 = b$, and then solve for x_1 and x_3 :

$$x_1 = ? \qquad x_3 = ?$$

Then use these to describe the solution set

$$\left\{ \left[\begin{array}{c} ? \\ a \\ ? \\ b \end{array} \right] \mid a, b \in \mathbb{R} \right\}$$

to the linear system.

Observation 1.1.15 Solving linear systems of two variables by graphing or substitution is reasonable for two-variable systems, but these simple techniques won't usually cut it for equations with more than two variables or more than two equations. For example,

$$\begin{aligned} -2x_1 - 4x_2 + x_3 - 4x_4 &= -8 \\ x_1 + 2x_2 + 2x_3 + 12x_4 &= -1 \\ x_1 + 2x_2 + x_3 + 8x_4 &= 1 \end{aligned}$$

has the exact same solution set as the system in the previous activity, but we'll want to learn new techniques to compute these solutions efficiently.

Remark 1.1.16 The only important information in a linear system are its coefficients and constants.

Original linear system:

Verbose standard form:

Coefficients/constants:

$$\begin{array}{lll} x_1 + 3x_3 = 3 & 1x_1 + 0x_2 + 3x_3 = 3 & 1 \ 0 \ 3 \mid 3 \\ 3x_1 - 2x_2 + 4x_3 = 0 & 3x_1 - 2x_2 + 4x_3 = 0 & 3 \ -2 \ 4 \mid 0 \\ -x_2 + x_3 = -2 & 0x_1 - 1x_2 + 1x_3 = -2 & 0 \ -1 \ 1 \mid -2 \end{array}$$

Definition 1.1.17 A system of m linear equations with n variables is often represented by writing its coefficients and constants in an **augmented matrix**: the $m \times n$ matrix of its

coefficients augmented with the m constant values as a final column.

$$\begin{aligned} a_{11}x_1 + a_{12}x_2 + \dots + a_{1n}x_n &= b_1 \\ a_{21}x_1 + a_{22}x_2 + \dots + a_{2n}x_n &= b_2 \\ &\vdots \qquad \qquad \qquad \vdots \qquad \qquad \vdots \\ a_{m1}x_1 + a_{m2}x_2 + \dots + a_{mn}x_n &= b_m \end{aligned}$$

$$\left[\begin{array}{cccc|c} a_{11} & a_{12} & \cdots & a_{1n} & b_1 \\ a_{21} & a_{22} & \cdots & a_{2n} & b_2 \\ \vdots & \vdots & \ddots & \vdots & \vdots \\ a_{m1} & a_{m2} & \cdots & a_{mn} & b_m \end{array} \right]$$

Sometimes, we will find it useful to refer only to the coefficients of the linear system (and ignore its constant terms). We call the $m \times n$ array consisting of these coefficients a **coefficient matrix**.

$$\left[\begin{array}{cccc} a_{11} & a_{12} & \cdots & a_{1n} \\ a_{21} & a_{22} & \cdots & a_{2n} \\ \vdots & \vdots & \ddots & \vdots \\ a_{m1} & a_{m2} & \cdots & a_{mn} \end{array} \right]$$

◇

The corresponding augmented matrix for this system is obtained by simply writing the coefficients and constants in matrix form.

Linear system:

$$\begin{aligned} x_1 &+ 3x_3 = 3 \\ 3x_1 - 2x_2 + 4x_3 &= 0 \\ -x_2 + x_3 &= -2 \end{aligned}$$

Augmented matrix:

$$\left[\begin{array}{ccc|c} 1 & 0 & 3 & 3 \\ 3 & -2 & 4 & 0 \\ 0 & -1 & 1 & -2 \end{array} \right]$$

Vector equation:

$$x_1 \begin{bmatrix} 1 \\ 3 \\ 0 \end{bmatrix} + x_2 \begin{bmatrix} 0 \\ -2 \\ -1 \end{bmatrix} + x_3 \begin{bmatrix} 3 \\ 4 \\ 1 \end{bmatrix} = \begin{bmatrix} 3 \\ 0 \\ -2 \end{bmatrix}$$

□

1.1.3 Individual Practice

Activity 1.1.19 Consider the following augmented matrices. For each of them, decide how many variables and how many equations the corresponding linear system has.

(a)

$$\left[\begin{array}{ccc|c} 2 & 1 & 3 & 3 \\ 1 & -2 & 4 & 3 \\ 3 & -1 & 7 & -1 \end{array} \right]$$

(b)

$$\left[\begin{array}{ccc|c} 2 & 1 & 3 & 3 \\ 1 & -2 & 4 & 3 \\ 3 & -1 & 7 & -1 \\ 3 & -1 & 7 & -1 \end{array} \right]$$

(c)

$$\left[\begin{array}{ccc|c} 2 & 0 & 3 & 3 \\ 1 & 0 & 4 & 3 \\ 3 & 0 & 7 & -1 \\ 3 & 0 & 7 & -1 \end{array} \right]$$

(d)

$$\left[\begin{array}{ccc|c} 2 & 1 & 3 & 3 \\ 1 & -2 & 4 & 3 \\ 0 & 0 & 0 & 0 \\ 3 & -1 & 7 & -1 \end{array} \right]$$

1.1.4 Videos



Standalone

Figure 1 Video: Converting between systems, vector equations, and augmented matrices

1.1.5 Exercises

Exercises available at <https://tbil.org/linear-algebra/preview/exercises/#/bank/LE1/>.

1.1.6 Mathematical Writing Explorations

Exploration 1.1.20 Choose a value for the real constant k such that the following system has one, many, or no solutions. In each case, write the solution set.

Consider the linear system:

$$\begin{aligned}x_1 - x_2 &= 1 \\ 3x_1 - 3x_2 &= k\end{aligned}$$

Exploration 1.1.21 Consider the linear system:

$$\begin{aligned}ax_1 + bx_2 &= j \\ cx_1 + dx_2 &= k\end{aligned}$$

Assume j and k are arbitrary real numbers.

- Choose values for a, b, c , and d , such that $ad - bc = 0$. Show that this system is inconsistent.
- Prove that, if $ad - bc \neq 0$, the system is consistent with exactly one solution.

Exploration 1.1.22 Given a set S , we can define a relation between two arbitrary elements $a, b \in S$. If the two elements are related, we denote this $a \sim b$.

Any relation on a set S that satisfies the properties below is an **equivalence relation**.

- **Reflexive:** For any $a \in S, a \sim a$
- **Symmetric:** For $a, b \in S$, if $a \sim b$, then $b \sim a$
- **Transitive:** for any $a, b, c \in S, a \sim b$ and $b \sim c$ implies $a \sim c$

For each of the following relations, show that it is or is not an equivalence relation.

- For $a, b \in \mathbb{R}, a \sim b$ if and only if $a \leq b$.
- For $a, b \in \mathbb{R}, a \sim b$ if and only if $|a| = |b|$.

1.1.7 Sample Problem and Solution

Sample problem [Example B.1.1](#).

1.2 Row Reduction of Matrices (LE2)

Learning Outcomes

- Explain why a matrix isn't in reduced row echelon form, and put a matrix in reduced row echelon form.

1.2.1 Warm Up

Activity 1.2.1 Consider the following matrices:

$$A = \left[\begin{array}{ccc|c} 1 & 0 & 3 & 3 \\ 3 & -2 & 4 & 0 \\ 0 & -1 & 1 & -2 \end{array} \right], \quad B = \begin{bmatrix} 2 & 5 & 3 \\ 1 & -2 & 4 \\ 3 & -1 & 7 \end{bmatrix}$$

- (a) Write down a linear system whose augmented matrix is A . Can you write down another?
- (b) Write down a linear system whose coefficient matrix is B . Can you write down another?

1.2.2 Class Activities

Definition 1.2.2 Two systems of linear equations (and their corresponding augmented matrices) are said to be **equivalent** if they have the same solution set.

For example, both of these systems share the same solution set $\left\{ \left[\begin{array}{c} 1 \\ 1 \end{array} \right] \right\}$.

$$\begin{array}{r} 3x_1 - 2x_2 = 1 \\ x_1 + 4x_2 = 5 \end{array} \qquad \begin{array}{r} 3x_1 - 2x_2 = 1 \\ 4x_1 + 2x_2 = 6 \end{array}$$

Therefore these augmented matrices are equivalent (even though they're not *equal*), which we denote with \sim :

$$\left[\begin{array}{cc|c} 3 & -2 & 1 \\ 1 & 4 & 5 \end{array} \right] \neq \left[\begin{array}{cc|c} 3 & -2 & 1 \\ 4 & 2 & 6 \end{array} \right]$$

$$\left[\begin{array}{cc|c} 3 & -2 & 1 \\ 1 & 4 & 5 \end{array} \right] \sim \left[\begin{array}{cc|c} 3 & -2 & 1 \\ 4 & 2 & 6 \end{array} \right]$$

◇

Activity 1.2.3 Consider whether these matrix manipulations (A) must keep the *same* solution set, or (B) might result in a *different* solution set for the corresponding linear system.

- (a) Swapping two rows, for example:

$$\left[\begin{array}{cc|c} 1 & 2 & 4 \\ 1 & 3 & 5 \end{array} \right] \sim \left[\begin{array}{cc|c} 1 & 3 & 5 \\ 1 & 2 & 4 \end{array} \right]$$

$$\begin{array}{ll} x + 2y = 4 & x + 3y = 5 \\ x + 3y = 5 & x + 2y = 4 \end{array}$$

A. Solutions must be the *same*.

B. Solutions might be *different*.

(b) Swapping two columns, for example:

$$\left[\begin{array}{cc|c} 1 & 2 & 4 \\ 1 & 3 & 5 \end{array} \right] \sim \left[\begin{array}{cc|c} 2 & 1 & 4 \\ 3 & 1 & 5 \end{array} \right]$$

$$\begin{array}{ll} x + 2y = 4 & 2x + y = 4 \\ x + 3y = 5 & 3x + y = 5 \end{array}$$

A. Solutions must be the *same*.

B. Solutions might be *different*.

(c) Add a constant to every term of a row, for example:

$$\left[\begin{array}{cc|c} 1 & 2 & 4 \\ 1 & 3 & 5 \end{array} \right] \sim \left[\begin{array}{cc|c} 1+3 & 2+3 & 4+3 \\ 1 & 3 & 5 \end{array} \right]$$

$$\begin{array}{ll} x + 2y = 4 & 4x + 5y = 7 \\ x + 3y = 5 & x + 3y = 5 \end{array}$$

A. Solutions must be the *same*.

B. Solutions might be *different*.

(d) Multiply a row by a nonzero constant, for example:

$$\left[\begin{array}{cc|c} 1 & 2 & 4 \\ 1 & 3 & 5 \end{array} \right] \sim \left[\begin{array}{cc|c} 3(1) & 3(2) & 3(4) \\ 1 & 3 & 5 \end{array} \right]$$

$$\begin{array}{ll} x + 2y = 3 & 3x + 6y = 12 \\ x + 3y = 5 & x + 3y = 5 \end{array}$$

A. Solutions must be the *same*.

B. Solutions might be *different*.

(e) Add one row to another row, for example:

$$\left[\begin{array}{cc|c} 1 & 2 & 4 \\ 1 & 3 & 5 \end{array} \right] \sim \left[\begin{array}{cc|c} 1 & 2 & 4 \\ 1+1 & 3+2 & 5+4 \end{array} \right]$$

$$\begin{array}{ll} x + 2y = 4 & ?x + ?y = ? \\ x + 3y = 5 & ?x + ?y = ? \end{array}$$

A. Solutions must be the *same*.

B. Solutions might be *different*.

(f) Replace a column with zeros, for example:

$$\left[\begin{array}{cc|c} 1 & 2 & 4 \\ 1 & 3 & 5 \end{array} \right] \sim \left[\begin{array}{cc|c} 1 & 0 & 4 \\ 1 & 0 & 5 \end{array} \right]$$

$$\begin{array}{ll} x + 2y = 4 & ?x + ?y = ? \\ x + 3y = 5 & ?x + ?y = ? \end{array}$$

A. Solutions must be the *same*.

B. Solutions might be *different*.

(g) Replace a row with zeros, for example:

$$\left[\begin{array}{cc|c} 1 & 2 & 4 \\ 1 & 3 & 5 \end{array} \right] \sim \left[\begin{array}{cc|c} 1 & 2 & 4 \\ 0 & 0 & 0 \end{array} \right]$$

$$x + 2y = 4 \quad ?x + ?y = ?$$

$$x + 3y = 5 \quad ?x + ?y = ?$$

A. Solutions must be the *same*.

B. Solutions might be *different*.

Activity 1.2.4

Observe what happens geometrically when we add a multiple of R_1 to R_2 in the below matrix:



$$\left[\begin{array}{cc|c} 1 & 2 & 3 \\ 3 & -4 & -21 \end{array} \right] \xrightarrow{R_2 + 0R_1 \rightarrow R_2} \left[\begin{array}{cc|c} 1 & 2 & 3 \\ 3 + 0(1) & -4 + 0(2) & -21 + 0(3) \end{array} \right]$$

$$= \left[\begin{array}{cc|c} 1 & 2 & 3 \\ 3 & -4 & -21 \end{array} \right]$$

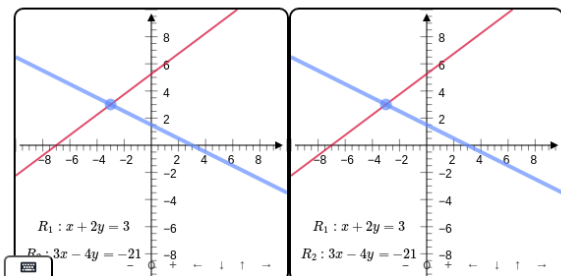

Standalone
Embed

How does adding row multiples to other rows affect a linear system's solution set?

A. Solutions must be the *same*.

B. Solutions might be *different*.

Definition 1.2.5 The following three **row operations** produce equivalent augmented matrices.

1. Swap two rows, for example, $R_1 \leftrightarrow R_2$:

$$\left[\begin{array}{cc|c} 1 & 2 & 3 \\ 4 & 5 & 6 \end{array} \right] \sim \left[\begin{array}{cc|c} 4 & 5 & 6 \\ 1 & 2 & 3 \end{array} \right]$$

2. Multiply a row by a nonzero constant, for example, $2R_1 \rightarrow R_1$:

$$\left[\begin{array}{cc|c} 1 & 2 & 3 \\ 4 & 5 & 6 \end{array} \right] \sim \left[\begin{array}{cc|c} 2(1) & 2(2) & 2(3) \\ 4 & 5 & 6 \end{array} \right]$$

3. Add a constant multiple of one row to another row, for example, $R_2 - 4R_1 \rightarrow R_2$:

$$\left[\begin{array}{cc|c} 1 & 2 & 3 \\ 4 & 5 & 6 \end{array} \right] \sim \left[\begin{array}{cc|c} 1 & 2 & 3 \\ 4 - 4(1) & 5 - 4(2) & 6 - 4(3) \end{array} \right]$$

Observe that we will use the following notation: (Combination of old rows) \rightarrow (New row).



Activity 1.2.6 Each of the following linear systems has the same solution set.

A)

$$\begin{aligned}x + 2y + z &= 3 \\ -x - y + z &= 1 \\ 2x + 5y + 3z &= 7\end{aligned}$$

B)

$$\begin{aligned}2x + 5y + 3z &= 7 \\ -x - y + z &= 1 \\ x + 2y + z &= 3\end{aligned}$$

C)

$$\begin{aligned}x - z &= 1 \\ y + 2z &= 4 \\ y + z &= 1\end{aligned}$$

D)

$$\begin{aligned}x + 2y + z &= 3 \\ y + 2z &= 4 \\ 2x + 5y + 3z &= 7\end{aligned}$$

E)

$$\begin{aligned}x - z &= 1 \\ y + 2z &= 4 \\ z &= 3\end{aligned}$$

F)

$$\begin{aligned}x + 2y + z &= 3 \\ y + 2z &= 4 \\ y + z &= 1\end{aligned}$$

Sort these six equivalent linear systems from most complicated to simplest (in your opinion).

Activity 1.2.7 Here we've written the sorted linear systems from [Activity 1.2.6](#) as augmented matrices.

$$\begin{aligned}& \left[\begin{array}{ccc|c} 2 & 5 & 3 & 7 \\ -1 & -1 & 1 & 1 \\ 1 & 2 & 1 & 3 \end{array} \right] \sim \left[\begin{array}{ccc|c} \boxed{1} & 2 & 1 & 3 \\ -1 & -1 & 1 & 1 \\ 2 & 5 & 3 & 7 \end{array} \right] \sim \left[\begin{array}{ccc|c} \boxed{1} & 2 & 1 & 3 \\ 0 & 1 & 2 & 4 \\ 2 & 5 & 3 & 7 \end{array} \right] \sim \\ & \sim \left[\begin{array}{ccc|c} \boxed{1} & 2 & 1 & 3 \\ 0 & \boxed{1} & 2 & 4 \\ 0 & 1 & 1 & 1 \end{array} \right] \sim \left[\begin{array}{ccc|c} \boxed{1} & 0 & -1 & 1 \\ 0 & \boxed{1} & 2 & 4 \\ 0 & 1 & 1 & 1 \end{array} \right] \sim \left[\begin{array}{ccc|c} \boxed{1} & 0 & -1 & 1 \\ 0 & \boxed{1} & 2 & 4 \\ 0 & 0 & -1 & -3 \end{array} \right]\end{aligned}$$

Assign the following row operations to each step used to manipulate each matrix to the next:

$$R_3 - 1R_2 \rightarrow R_3$$

$$R_2 + 1R_1 \rightarrow R_2$$

$$R_1 \leftrightarrow R_3$$

$$R_3 - 2R_1 \rightarrow R_3$$

$$R_1 - 2R_3 \rightarrow R_1$$

Definition 1.2.8 A matrix is in **reduced row echelon form (RREF)** if

1. The leftmost nonzero term of each row is 1. We call these terms **pivots**.
2. Each pivot is to the right of every higher pivot.
3. Each term that is either above or below a pivot is 0.
4. All zero rows (rows whose terms are all 0) are at the bottom of the matrix.

Every matrix has a unique reduced row echelon form. If A is a matrix, we write $\text{RREF}(A)$ for the reduced row echelon form of that matrix. \diamond

Activity 1.2.9 Recall that a matrix is in **reduced row echelon form (RREF)** if

1. The leftmost nonzero term of each row is 1. We call these terms **pivots**.

2. Each pivot is to the right of every higher pivot.
3. Each term that is either above or below a pivot is 0.
4. All zero rows (rows whose terms are all 0) are at the bottom of the matrix.

For each matrix, mark the leading terms, and label it as RREF or not RREF. For the ones not in RREF, determine which rule is violated and how it might be fixed.

$$A = \left[\begin{array}{ccc|c} 1 & 0 & 0 & 3 \\ 0 & 0 & 1 & -1 \\ 0 & 0 & 0 & 0 \end{array} \right] \quad B = \left[\begin{array}{ccc|c} 1 & 0 & 4 & 3 \\ 0 & 1 & 0 & -1 \\ 0 & 0 & 1 & 2 \end{array} \right] \quad C = \left[\begin{array}{ccc|c} 0 & 0 & 0 & 0 \\ 1 & 2 & 0 & 3 \\ 0 & 0 & 1 & -1 \end{array} \right]$$

Activity 1.2.10 Recall that a matrix is in **reduced row echelon form (RREF)** if

1. The leftmost nonzero term of each row is 1. We call these terms **pivots**.
2. Each pivot is to the right of every higher pivot.
3. Each term that is either above or below a pivot is 0.
4. All zero rows (rows whose terms are all 0) are at the bottom of the matrix.

For each matrix, mark the leading terms, and label it as RREF or not RREF. For the ones not in RREF, determine which rule is violated and how it might be fixed.

$$D = \left[\begin{array}{ccc|c} 1 & 0 & 2 & -3 \\ 0 & 3 & 3 & -3 \\ 0 & 0 & 0 & 0 \end{array} \right] \quad E = \left[\begin{array}{ccc|c} 0 & 1 & 0 & 7 \\ 1 & 0 & 0 & 4 \\ 0 & 0 & 0 & 0 \end{array} \right] \quad F = \left[\begin{array}{ccc|c} 1 & 0 & 0 & 4 \\ 0 & 1 & 0 & 7 \\ 0 & 0 & 1 & 0 \end{array} \right]$$

Remark 1.2.11 In practice, if we simply need to convert a matrix into reduced row echelon form, we use technology to do so.

However, it is also important to understand the **Gauss-Jordan elimination** algorithm that a computer or calculator uses to convert a matrix (augmented or not) into reduced row echelon form. Understanding this algorithm will help us better understand how to interpret the results in many applications we use it for in [Chapter 2](#).

Activity 1.2.12 Consider the matrix

$$\left[\begin{array}{cccc} 2 & 6 & -1 & 6 \\ 1 & 3 & -1 & 2 \\ -1 & -3 & 2 & 0 \end{array} \right].$$

Which row operation is the best choice for the first move in converting to RREF?

- A. Add row 3 to row 2 ($R_2 + R_3 \rightarrow R_2$)
- B. Add row 2 to row 3 ($R_3 + R_2 \rightarrow R_3$)
- C. Swap row 1 to row 2 ($R_1 \leftrightarrow R_2$)

D. Add -2 row 2 to row 1 ($R_1 - 2R_2 \rightarrow R_1$)

Activity 1.2.13 Consider the matrix

$$\begin{bmatrix} \boxed{1} & 3 & -1 & 2 \\ 2 & 6 & -1 & 6 \\ -1 & -3 & 2 & 0 \end{bmatrix}.$$

Which row operation is the best choice for the next move in converting to RREF?

A. Add row 1 to row 3 ($R_3 + R_1 \rightarrow R_3$)

B. Add -2 row 1 to row 2 ($R_2 - 2R_1 \rightarrow R_2$)

C. Add 2 row 2 to row 3 ($R_3 + 2R_2 \rightarrow R_3$)

D. Add 2 row 3 to row 2 ($R_2 + 2R_3 \rightarrow R_2$)

Activity 1.2.14 Consider the matrix

$$\begin{bmatrix} \boxed{1} & 3 & -1 & 2 \\ 0 & 0 & 1 & 2 \\ 0 & 0 & 1 & 2 \end{bmatrix}.$$

Which row operation is the best choice for the next move in converting to RREF?

A. Add row 1 to row 2 ($R_2 + R_1 \rightarrow R_2$)

B. Add -1 row 3 to row 2 ($R_2 - R_3 \rightarrow R_2$)

C. Add -1 row 2 to row 3 ($R_3 - R_2 \rightarrow R_3$)

D. Add row 2 to row 1 ($R_1 + R_2 \rightarrow R_1$)

Observation 1.2.15 The steps for the Gauss-Jordan elimination algorithm may be summarized as follows:

1. Ignoring any rows that already have marked pivots, identify the leftmost column with a nonzero entry.
2. Use row operations to obtain a pivot of value 1 in the topmost row that does not already have a marked pivot.
3. Mark this pivot, then use row operations to change all values above and below the marked pivot to 0.
4. Repeat these steps until the matrix is in RREF.

In particular, *once a pivot is marked, it should remain in the same position.* This will keep you from undoing your progress towards an RREF matrix.

Activity 1.2.16 Complete the following RREF calculation (multiple row operations may be needed for certain steps):

$$\begin{aligned}
 A &= \begin{bmatrix} 2 & 3 & 2 & 3 \\ -2 & 1 & 6 & 1 \\ -1 & -3 & -4 & 1 \end{bmatrix} \sim \begin{bmatrix} \boxed{1} & ? & ? & ? \\ -2 & 1 & 6 & 1 \\ -1 & -3 & -4 & 1 \end{bmatrix} \sim \begin{bmatrix} \boxed{1} & ? & ? & ? \\ 0 & ? & ? & ? \\ 0 & ? & ? & ? \end{bmatrix} \\
 &\sim \begin{bmatrix} \boxed{1} & ? & ? & ? \\ 0 & \boxed{1} & ? & ? \\ 0 & ? & ? & ? \end{bmatrix} \sim \begin{bmatrix} \boxed{1} & 0 & ? & ? \\ 0 & \boxed{1} & ? & ? \\ 0 & 0 & ? & ? \end{bmatrix} \sim \dots \sim \begin{bmatrix} \boxed{1} & 0 & -2 & 0 \\ 0 & \boxed{1} & 2 & 0 \\ 0 & 0 & 0 & 1 \end{bmatrix}
 \end{aligned}$$

Activity 1.2.17 Consider the matrix

$$A = \begin{bmatrix} 2 & 4 & 2 & -4 \\ -2 & -4 & 1 & 1 \\ 3 & 6 & -1 & -4 \end{bmatrix}.$$

Compute $\text{RREF}(A)$.

Activity 1.2.18 Consider the non-augmented and augmented matrices

$$A = \begin{bmatrix} 2 & 4 & 2 & -4 \\ -2 & -4 & 1 & 1 \\ 3 & 6 & -1 & -4 \end{bmatrix} \quad B = \left[\begin{array}{ccc|c} 2 & 4 & 2 & -4 \\ -2 & -4 & 1 & 1 \\ 3 & 6 & -1 & -4 \end{array} \right].$$

Can $\text{RREF}(A)$ be used to find $\text{RREF}(B)$?

- Yes, $\text{RREF}(A)$ and $\text{RREF}(B)$ are exactly the same.
- Yes, $\text{RREF}(A)$ may be slightly modified to find $\text{RREF}(B)$.
- No, a new calculation is required.

Activity 1.2.19 Free browser-based technologies for mathematical computation are available online.

- Go to <https://sagecell.sagemath.org/>.
- In the dropdown on the right, you can select a number of different languages. Select "Octave" for the Matlab-compatible syntax used by this text.
- Type `rref([1, 3, 2; 2, 5, 7])` and then press the Evaluate button to compute the RREF of $\begin{bmatrix} 1 & 3 & 2 \\ 2 & 5 & 7 \end{bmatrix}$.
- Now try using whitespace to write out the matrix and compute RREF instead:

```

|  A = [1 3 2
|      2 5 7]
|
|  rref(A)

```

Activity 1.2.20 In the HTML version of this text, code cells are often embedded for your convenience when RREFs need to be computed.

Try this out to compute RREF $\left[\begin{array}{cc|c} 2 & -3 & 1 \\ 3 & 0 & 6 \end{array} \right]$.

```
rref([2, -3, 1; 3, 0, 6])
```

```
A = [2 -3 1
      3  0 6]
```

```
rref(A)
```

1.2.3 Individual Practice

Activity 1.2.21 Find three examples of linear systems for which the RREF of their augmented matrices is equal to

$$\left[\begin{array}{ccc|c} 1 & 4 & 2 & -4 \\ 0 & 0 & 0 & 0 \\ 0 & 0 & 0 & 0 \end{array} \right]$$

Activity 1.2.22 Which of the following matrices are not in RREF?

$$A = \left[\begin{array}{ccc|c} 1 & 0 & 2 & -3 \\ 0 & 3 & 3 & -3 \\ 0 & 0 & 0 & 1 \end{array} \right]$$

$$B = \left[\begin{array}{ccc|c} 1 & 0 & 0 & 7 \\ 0 & 1 & 0 & 4 \\ 0 & 0 & 1 & 3 \end{array} \right]$$

$$C = \left[\begin{array}{ccc|c} 1 & 0 & 0 & 4 \\ 0 & 1 & 0 & 7 \\ 0 & 0 & 0 & 4 \end{array} \right]$$

1.2.4 Videos

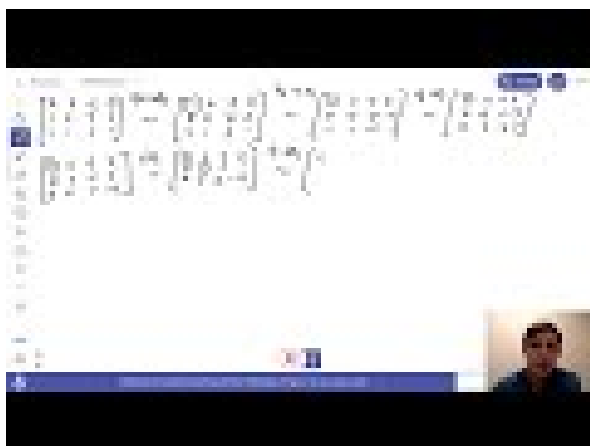

Standalone

Figure 2 Video: Row reduction

1.2.5 Exercises

Exercises available at <https://tbil.org/linear-algebra/preview/exercises/#/bank/LE2/>.

1.2.6 Mathematical Writing Explorations

Exploration 1.2.23 Prove that Gauss-Jordan Elimination preserves the solution set of a system of linear equations in n variables. Make sure your proof includes each of the following. Just because I've used bullet points here does not mean you should use bullet points in your proof.

- Write an arbitrary system of linear equations in n variables. Your notation should be unambiguous.
- Label an element of your solution set. You won't know what it is exactly, so you'll have to use a variable. Remember what it means (by definition!) to be in the solution set.
- Describe the three operations used in Gauss-Jordan Elimination.
- Consider all three operations in Gauss-Jordan Elimination. After each one is used, show that the element of the solution set you picked still satisfies the definition.

Exploration 1.2.24 Let $M_{2,2}$ indicate the set of all 2×2 matrices with real entries. Show that equivalence of matrices as defined in this section is an equivalence relation, as in exploration [Exploration 1.1.22](#)

1.2.7 Sample Problem and Solution

Sample problem [Example B.1.2](#).

1.3 Counting Solutions for Linear Systems (LE3)

Learning Outcomes

- Determine the number of solutions for a system of linear equations or a vector equation.

1.3.1 Warm Up

Activity 1.3.1

- Without referring to your Activity Book, which of the four criteria for a matrix to be in Reduced Row Echelon Form (RREF) can you recall?
- Which, if any, of the following matrices are in RREF? You may refer to the Activity Book now for criteria that you may have forgotten.

$$P = \left[\begin{array}{ccc|c} 1 & 0 & \frac{2}{3} & -3 \\ 0 & 3 & 3 & -\frac{3}{5} \\ 0 & 0 & 0 & 0 \end{array} \right] \quad Q = \left[\begin{array}{ccc|c} 0 & 1 & 0 & 7 \\ 1 & 0 & 0 & 4 \\ 0 & 0 & 0 & 0 \end{array} \right] \quad R = \left[\begin{array}{ccc|c} 1 & 0 & \frac{1}{2} & 4 \\ 0 & 1 & 0 & 7 \\ 0 & 0 & 1 & 0 \end{array} \right]$$

1.3.2 Class Activities

Remark 1.3.2 We will frequently need to know the reduced row echelon form of matrices during the remainder of this course, so unless you're told otherwise, feel free to use technology (see [Activity 1.2.19](#)) to compute RREFs efficiently.

Activity 1.3.3 Consider the following system of equations.

$$3x_1 - 2x_2 + 13x_3 = 6$$

$$2x_1 - 2x_2 + 10x_3 = 2$$

$$-x_1 + 3x_2 - 6x_3 = 11$$

$$4x_1 + x_2 + x_3 = 1.$$

- (a) Convert this to an augmented matrix and use technology to compute its reduced row echelon form:

$$\text{RREF} \left[\begin{array}{ccc|c} ? & ? & ? & ? \\ ? & ? & ? & ? \\ ? & ? & ? & ? \\ ? & ? & ? & ? \end{array} \right] = \left[\begin{array}{ccc|c} ? & ? & ? & ? \\ ? & ? & ? & ? \\ ? & ? & ? & ? \\ ? & ? & ? & ? \end{array} \right]$$

- (b) Use the RREF matrix to write a linear system equivalent to the original system.
 (c) How many solutions must this system have?

A. Zero

B. Only one

C. Infinitely-many

$$A = \begin{bmatrix} 3 & -2 & 13 & 6 \\ 2 & -2 & 10 & 2 \\ -1 & 3 & -6 & 11 \\ 4 & 1 & 1 & 1 \end{bmatrix}$$

rref(A)

Activity 1.3.4 Consider the vector equation

$$x_1 \begin{bmatrix} 3 \\ 2 \\ -1 \\ 3 \end{bmatrix} + x_2 \begin{bmatrix} -2 \\ -2 \\ 0 \\ 7 \end{bmatrix} + x_3 \begin{bmatrix} 13 \\ 10 \\ -3 \\ 0 \end{bmatrix} = \begin{bmatrix} 6 \\ 2 \\ 1 \\ -2 \end{bmatrix}$$

- (a) Convert this to an augmented matrix and use technology to compute its reduced row echelon form:

$$\text{RREF} \left[\begin{array}{ccc|c} ? & ? & ? & ? \\ ? & ? & ? & ? \\ ? & ? & ? & ? \\ ? & ? & ? & ? \end{array} \right] = \left[\begin{array}{ccc|c} ? & ? & ? & ? \\ ? & ? & ? & ? \\ ? & ? & ? & ? \\ ? & ? & ? & ? \end{array} \right]$$

- (b) Use the RREF matrix to write a linear system equivalent to the original system.

(c) How many solutions must this system have?

A. Zero

B. Only one

C. Infinitely-many

`rref([3, -2, 13, 6; 2, -2, 10, 2; -1, 0, -3, 1; 3, 7, 0, -2])`

Activity 1.3.5 What contradictory equations besides $0 = 1$ may be obtained from the RREF of an augmented matrix?

A. $x = 0$ is an obtainable contradiction

B. $x = y$ is an obtainable contradiction

C. $0 = 17$ is an obtainable contradiction

D. $0 = 1$ is the only obtainable contradiction

Activity 1.3.6 Consider the following linear system.

$$\begin{aligned}x_1 + 2x_2 + 3x_3 &= 1 \\2x_1 + 4x_2 + 8x_3 &= 0 \\3x_1 + 6x_2 + 11x_3 &= 1 \\x_1 + 2x_2 + 5x_3 &= -1\end{aligned}$$

(a) Find its corresponding augmented matrix A and find $\text{RREF}(A)$.

(b) Use the RREF matrix to write a linear system equivalent to the original system.

(c) How many solutions must this system have?

A. Zero

B. One

C. Infinitely-many

Fact 1.3.7 *By finding $\text{RREF}(A)$ from a linear system's corresponding augmented matrix A , we can immediately tell how many solutions the system has.*

- *If the linear system given by $\text{RREF}(A)$ includes the contradiction*

$$0 = 1,$$

that is, the RREF matrix includes the row

$$\left[0 \ \cdots \ 0 \mid 1 \right],$$

then the system is inconsistent, which means it has zero solutions and we may write

$$\text{Solution set} = \{\} \quad \text{or} \quad \text{Solution set} = \emptyset.$$

- *If the linear system given by $\text{RREF}(A)$ sets each variable of the system to a single value; that is we have:*

$$x_1 = s_1$$

$$\begin{aligned}x_2 &= s_2 \\ &\vdots \\ x_n &= s_n\end{aligned}$$

(with some possible extra $0 = 0$ equations), then the system is consistent with exactly one solution, and we may write

$$\text{Solution} = \begin{bmatrix} s_1 \\ s_2 \\ \vdots \\ s_n \end{bmatrix} \quad \text{but} \quad \text{Solution set} = \left\{ \begin{bmatrix} s_1 \\ s_2 \\ \vdots \\ s_n \end{bmatrix} \right\}.$$

- Otherwise, the system given by the RREF matrix must not include a $0 = 1$ contradiction while including at least one equation with multiple variables. This means it is consistent with infinitely-many different solutions. We'll learn how to find such solution sets in [Section 1.4](#).

Activity 1.3.8 Consider each of the following systems of linear equations or vector equations.

(a)

$$\begin{aligned}x_1 - x_2 - 3x_3 &= 8 \\ 3x_1 - 2x_2 - 5x_3 &= 17 \\ x_1 - x_2 - 2x_3 &= 7 \\ 10x_1 - 8x_2 - 21x_3 &= 65\end{aligned}$$

- Explain and demonstrate how to find a simpler linear system that has the same solution set.
- Explain whether this solution set has no solutions, one solution, or infinitely-many solutions. If the set is finite, describe it using set notation.

(b)

$$\begin{aligned}x_1 - 5x_2 - 15x_3 &= -8 \\ &x_2 + 3x_3 = 1 \\ x_1 &= 2 \\ 5x_1 - 7x_2 - 21x_3 &= -10\end{aligned}$$

- Explain and demonstrate how to find a simpler linear system that has the same solution set.
- Explain whether this solution set has no solutions, one solution, or infinitely-many solutions. If the set is finite, describe it using set notation.

(c)

$$\begin{aligned}-2x_1 + 2x_2 + 5x_3 &= 1 \\ -x_1 + x_2 + 2x_3 &= 1 \\ 2x_1 - 2x_2 + x_3 &= -7 \\ -2x_1 + 2x_2 + 16x_3 &= -10\end{aligned}$$

- (i) Explain and demonstrate how to find a simpler linear system that has the same solution set.
- (ii) Explain whether this solution set has no solutions, one solution, or infinitely-many solutions. If the set is finite, describe it using set notation.

1.3.3 Individual Practice

Activity 1.3.9 In [Fact 1.1.11](#), we stated, but did not prove the assertion that all linear systems are one of the following:

1. *Consistent with one solution*: its solution set contains a single vector, e.g. $\left\{ \begin{bmatrix} 1 \\ 2 \\ 3 \end{bmatrix} \right\}$
2. *Consistent with infinitely-many solutions*: its solution set contains infinitely many vectors, e.g. $\left\{ \begin{bmatrix} 1 \\ 2 - 3a \\ a \end{bmatrix} \mid a \in \mathbb{R} \right\}$
3. *Inconsistent*: its solution set is the empty set, denoted by either $\{\}$ or \emptyset .

Explain why this fact is a consequence of [Fact 1.3.7](#) above.

1.3.4 Videos

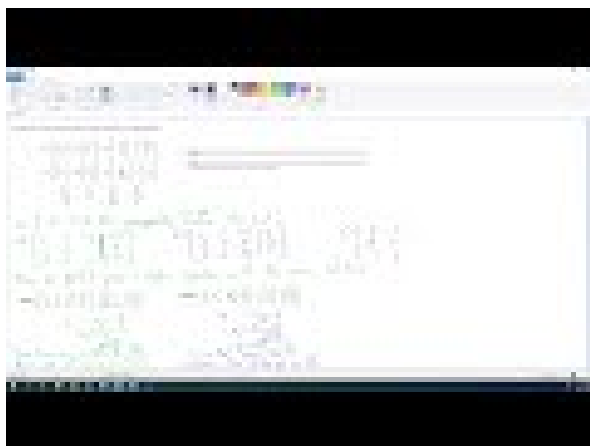

[Standalone](#)

Figure 3 Video: Finding the number of solutions for a system

1.3.5 Exercises

Exercises available at <https://tbil.org/linear-algebra/preview/exercises/#/bank/LE3/>.

1.3.6 Mathematical Writing Explorations

Exploration 1.3.10 A system of equations with all constants equal to 0 is called **homogeneous**. These are addressed in detail in section [Section 2.7](#)

- Choose three systems of equations from this chapter that you have already solved. Replace the constants with 0 to make the systems homogeneous. Solve the homogeneous systems and make a conjecture about the relationship between the earlier solutions you found and the associated homogeneous systems.
- Prove or disprove. A system of linear equations is homogeneous if and only if it has the zero vector as a solution.

1.3.7 Sample Problem and Solution

Sample problem [Example B.1.3](#).

1.4 Linear Systems with Infinitely-Many Solutions (LE4)

Learning Outcomes

- Compute the solution set for a system of linear equations or a vector equation with infinitely many solutions.

1.4.1 Warm Up

Activity 1.4.1 Write down any three linear systems and determine if they are consistent, have a single solution, or have infinitely many solutions.

1.4.2 Class Activities

Activity 1.4.2 Consider this simplified linear system found to be equivalent to the system from [Activity 1.3.6](#):

$$\begin{aligned}x_1 + 2x_2 &= 4 \\ x_3 &= -1\end{aligned}$$

Earlier, we determined this system has infinitely-many solutions.

(a) Let $x_1 = a$ and write the solution set in the form $\left\{ \begin{bmatrix} a \\ ? \\ ? \end{bmatrix} \mid a \in \mathbb{R} \right\}$.

(b) Let $x_2 = b$ and write the solution set in the form $\left\{ \begin{bmatrix} ? \\ b \\ ? \end{bmatrix} \mid b \in \mathbb{R} \right\}$.

- (c) Which of these was easier? What features of the RREF matrix $\left[\begin{array}{ccc|c} \boxed{1} & 2 & 0 & 4 \\ 0 & 0 & \boxed{1} & -1 \end{array} \right]$ caused this?

Definition 1.4.3 Recall that the pivots of a matrix in RREF form are the leading 1s in each non-zero row.

The pivot columns in an augmented matrix correspond to the **bound variables** in the system of equations (x_1, x_3 below). The remaining variables are called **free variables** (x_2 below).

$$\left[\begin{array}{ccc|c} \boxed{1} & 2 & 0 & 4 \\ 0 & 0 & \boxed{1} & -1 \end{array} \right]$$

To efficiently solve a system in RREF form, assign letters to the free variables, and then solve for the bound variables. \diamond

Activity 1.4.4 Find the solution set for the system

$$\begin{aligned} 2x_1 - 2x_2 - 6x_3 + x_4 - x_5 &= 3 \\ -x_1 + x_2 + 3x_3 - x_4 + 2x_5 &= -3 \\ x_1 - 2x_2 - x_3 + x_4 + x_5 &= 2 \end{aligned}$$

by doing the following.

- (a) Row-reduce its augmented matrix.
 (b) Assign letters to the free variables (given by the non-pivot columns):

$$? = a$$

$$? = b$$

- (c) Solve for the bound variables (given by the pivot columns) to show that

$$? = 1 + 5a + 2b$$

$$? = 1 + 2a + 3b$$

$$? = 3 + 3b$$

- (d) Replace x_1 through x_5 with the appropriate expressions of a, b in the following set-builder notation.

$$\left\{ \left[\begin{array}{c} x_1 \\ x_2 \\ x_3 \\ x_4 \\ x_5 \end{array} \right] \middle| a, b \in \mathbb{R} \right\}$$

Remark 1.4.5 Don't forget to correctly express the solution set of a linear system. Systems with zero or one solutions may be written by listing their elements, while systems with infinitely-many solutions may be written using set-builder notation.

- *Inconsistent:* \emptyset or $\{\}$

- (not 0 or $\begin{bmatrix} 0 \\ 0 \\ 0 \end{bmatrix}$)

- *Consistent with one solution:* e.g. $\left\{ \begin{bmatrix} 1 \\ 2 \\ 3 \end{bmatrix} \right\}$

- (not just $\begin{bmatrix} 1 \\ 2 \\ 3 \end{bmatrix}$)

- *Consistent with infinitely-many solutions:* e.g. $\left\{ \begin{bmatrix} 1 \\ 2 - 3a \\ a \end{bmatrix} \mid a \in \mathbb{R} \right\}$

- (not just $\begin{bmatrix} 1 \\ 2 - 3a \\ a \end{bmatrix}$)

Activity 1.4.6 Consider the following system of linear equations.

$$x_1 \begin{bmatrix} 1 \\ 0 \\ 1 \end{bmatrix} + x_2 \begin{bmatrix} 0 \\ 1 \\ -1 \end{bmatrix} + x_3 \begin{bmatrix} -1 \\ 5 \\ -5 \end{bmatrix} + x_4 \begin{bmatrix} -3 \\ 13 \\ -13 \end{bmatrix} = \begin{bmatrix} -3 \\ 12 \\ -12 \end{bmatrix}.$$

- Explain how to find a simpler system or vector equation that has the same solution set.
- Explain how to describe this solution set using set notation.

Activity 1.4.7 Consider the following system of linear equations.

$$\begin{aligned} x_1 & - 2x_3 & = & -3 \\ 5x_1 + x_2 & - 7x_3 & = & -18 \\ 5x_1 - x_2 & - 13x_3 & = & -12 \\ x_1 + 3x_2 & + 7x_3 & = & -12 \end{aligned}$$

- Explain how to find a simpler system or vector equation that has the same solution set.
- Explain how to describe this solution set using set notation.

1.4.3 Individual Practice

Activity 1.4.8 Consider the following linear system, its augmented matrix A , and $\text{RREF}(A)$:

$$\begin{aligned} x_1 - x_2 + x_3 &= 4 \\ x_2 - 2x_3 &= -1 \\ x_2 - 2x_3 &= -3 \\ x_1 + 2x_2 - 5x_3 &= 0 \end{aligned}$$

$$A = \left[\begin{array}{ccc|c} 1 & -1 & 1 & 4 \\ 0 & 1 & -2 & -1 \\ 0 & 1 & -2 & -3 \\ 1 & 2 & -5 & 0 \end{array} \right], \quad \text{RREF}(A) = \left[\begin{array}{ccc|c} 1 & 0 & -1 & 0 \\ 0 & 1 & -2 & 0 \\ 0 & 0 & 0 & 1 \\ 0 & 0 & 0 & 0 \end{array} \right].$$

All of the following statements are not accurate or otherwise incorrect; identify what is problematic about the statements and correct them.

- (a) The matrix A is inconsistent.
- (b) The linear system has two bound variables and one free variable.
- (c) The solution set to the given linear system is $\{\emptyset\}$.

Activity 1.4.9 Consider the following linear system, its augmented matrix B , and $\text{RREF}(B)$:

$$\begin{aligned} 2x_1 - 2x_2 - 8x_3 + 3x_4 - 9x_5 &= -17 \\ -x_1 + x_3 - x_4 + 2x_5 &= 6 \\ 2x_1 - x_2 - 5x_3 + x_4 - 5x_5 &= -10 \\ -x_1 + 3x_2 + 10x_3 + 7x_5 &= 6 \end{aligned}$$

$$B = \left[\begin{array}{ccccc|c} 2 & -2 & -8 & 3 & -9 & -17 \\ -1 & 0 & 1 & -1 & 2 & 6 \\ 2 & -1 & -5 & 1 & -5 & -10 \\ -1 & 3 & 10 & 0 & 7 & 6 \end{array} \right]$$

$$\text{RREF}(B) = \left[\begin{array}{ccccc|c} 1 & 0 & -1 & 0 & -1 & -3 \\ 0 & 1 & 3 & 0 & 2 & 1 \\ 0 & 0 & 0 & 1 & -1 & -3 \\ 0 & 0 & 0 & 0 & 0 & 0 \end{array} \right].$$

All of the following statements are not accurate or otherwise incorrect; identify what is problematic about the statements and correct them.

- (a) The matrix B is consistent with infinitely many solutions.

(b) The solution set is given by

$$\begin{bmatrix} a + b - 3 \\ -3a - 2b + 1 \\ a \\ b - 3 \\ b \end{bmatrix}.$$

(c) The variables x_3, x_5 are free. Setting them equal to a, b respectively and solving for the bound variables, the solution set to the linear system is given by

$$\left\{ \left[\begin{array}{c} a + b - 3 \\ -3a - 2b + 1 \\ b - 3 \end{array} \right] \middle| a, b \in \mathbb{R} \right\}.$$

1.4.4 Videos



Standalone

Figure 4 Video: Solving a system of linear equations with infinitely-many solutions

1.4.5 Exercises

Exercises available at <https://tbil.org/linear-algebra/preview/exercises/#/bank/LE4/>.

1.4.6 Mathematical Writing Explorations

Exploration 1.4.10 Construct a system of 3 equations in 3 variables having:

- 0 free variables
- 1 free variable
- 2 free variables

In each case, solve the system you have created. Conjecture a relationship between the number of free variables and the type of solution set that can be obtained from a given system.

Exploration 1.4.11 For each of the following, decide if it's true or false. If you think it's true, can we construct a proof? If you think it's false, can we find a counterexample?

- If the coefficient matrix of a system of linear equations has a pivot in the rightmost column, then the system is inconsistent.
- If a system of equations has two equations and four unknowns, then it must be consistent.

- If a system of equations having four equations and three unknowns is consistent, then the solution is unique.
- Suppose that a linear system has four equations and four unknowns and that the coefficient matrix has four pivots. Then the linear system is consistent and has a unique solution.
- Suppose that a linear system has five equations and three unknowns and that the coefficient matrix has a pivot in every column. Then the linear system is consistent and has a unique solution.

1.4.7 Sample Problem and Solution

Sample problem [Example B.1.4](#).

Chapter 2

Euclidean Vectors (EV)

Learning Outcomes

What is a space of Euclidean vectors?

By the end of this chapter, you should be able to...

1. Determine if a Euclidean vector can be written as a linear combination of a given set of Euclidean vectors by solving an appropriate vector equation.
2. Determine if a set of Euclidean vectors spans \mathbb{R}^n by solving appropriate vector equations.
3. Determine if a subset of \mathbb{R}^n is a subspace or not.
4. Determine if a set of Euclidean vectors is linearly dependent or independent by solving an appropriate vector equation.
5. Explain why a set of Euclidean vectors is or is not a basis of \mathbb{R}^n .
6. Compute a basis for the subspace spanned by a given set of Euclidean vectors, and determine the dimension of the subspace.
7. Find a basis for the solution set of a homogeneous system of equations.

Readiness Assurance. Before beginning this chapter, you should be able to...

1. Use set builder notation to describe sets of vectors.
 - Review: [YouTube](#)¹
2. Add Euclidean vectors and multiply Euclidean vectors by scalars.
 - Review: [Khan Academy \(1\)](#)² [\(2\)](#)³

¹youtu.be/xnfUZ-NTsCE

²www.khanacademy.org/math/linear-algebra/vectors-and-spaces/vectors/v/adding-vectors

³www.khanacademy.org/math/linear-algebra/vectors-and-spaces/vectors/v/

3. Perform basic manipulations of augmented matrices and linear systems.

- Review: [Section 1.1](#), [Section 1.2](#), [Section 1.3](#)

2.1 Linear Combinations (EV1)

Learning Outcomes

- Determine if a Euclidean vector can be written as a linear combination of a given set of Euclidean vectors by solving an appropriate vector equation.

2.1.1 Warm Up

Activity 2.1.1 Discuss which of the vectors $\vec{u} = \begin{bmatrix} 1 \\ -1 \\ 2 \end{bmatrix}$ and $\vec{v} = \begin{bmatrix} 0 \\ 3 \\ -1 \end{bmatrix}$ is a solution to the given vector equation:

$$x_1 \begin{bmatrix} -1 \\ 2 \\ 3 \end{bmatrix} + x_2 \begin{bmatrix} 2 \\ -1 \\ 0 \end{bmatrix} + x_3 \begin{bmatrix} 1 \\ -1 \\ 1 \end{bmatrix} = \begin{bmatrix} -1 \\ 1 \\ 5 \end{bmatrix}$$

2.1.2 Class Activities

Note 2.1.2 We've been working with **Euclidean vector spaces** of the form

$$\mathbb{R}^n = \left\{ \left[\begin{array}{c} x_1 \\ x_2 \\ \vdots \\ x_n \end{array} \right] \mid x_1, x_2, \dots, x_n \in \mathbb{R} \right\}.$$

There are other kinds of **vector spaces** as well (e.g. polynomials, matrices), which we will investigate in [Section 3.5](#). But understanding the structure of *Euclidean* vectors on their own will be beneficial, even when we turn our attention to other kinds of vectors.

We will use the phrase **vector space** freely from this point on, even while delaying a formal definition. Readers can choose to interpret this to mean *Euclidean vector space*, i.e. \mathbb{R}^n for some n , if they wish; we do this as all of the statements we make using the term **vector space** are also true for all vector spaces as defined in [Definition 3.5.7](#).

Likewise, when we multiply a vector by a real number, as in $-3 \begin{bmatrix} 1 \\ -1 \\ 2 \end{bmatrix} = \begin{bmatrix} -3 \\ 3 \\ -6 \end{bmatrix}$, we

refer to this real number as a **scalar**.

multiplying-vector-by-scalar

We often use letters like V and W to refer to vector spaces (Euclidean or otherwise)

Definition 2.1.3 A **linear combination** of a set of vectors $\{\vec{v}_1, \vec{v}_2, \dots, \vec{v}_n\}$ is given by $c_1\vec{v}_1 + c_2\vec{v}_2 + \dots + c_n\vec{v}_n$ for any choice of scalar multiples c_1, c_2, \dots, c_n .

For example, we can say $\begin{bmatrix} 3 \\ 0 \\ 5 \end{bmatrix}$ is a linear combination of the vectors $\begin{bmatrix} 1 \\ -1 \\ 2 \end{bmatrix}$ and $\begin{bmatrix} 1 \\ 2 \\ 1 \end{bmatrix}$ since

$$\begin{bmatrix} 3 \\ 0 \\ 5 \end{bmatrix} = 2 \begin{bmatrix} 1 \\ -1 \\ 2 \end{bmatrix} + 1 \begin{bmatrix} 1 \\ 2 \\ 1 \end{bmatrix}.$$

◇

Definition 2.1.4 The **span** of a set of vectors is the collection of all linear combinations of that set:

$$\text{span}\{\vec{v}_1, \vec{v}_2, \dots, \vec{v}_n\} = \{c_1\vec{v}_1 + c_2\vec{v}_2 + \dots + c_n\vec{v}_n \mid c_i \in \mathbb{R}\}.$$

For example:

$$\text{span} \left\{ \begin{bmatrix} 1 \\ -1 \\ 2 \end{bmatrix}, \begin{bmatrix} 1 \\ 2 \\ 1 \end{bmatrix} \right\} = \left\{ a \begin{bmatrix} 1 \\ -1 \\ 2 \end{bmatrix} + b \begin{bmatrix} 1 \\ 2 \\ 1 \end{bmatrix} \mid a, b \in \mathbb{R} \right\}.$$

◇

Activity 2.1.5 Consider $\text{span} \left\{ \begin{bmatrix} 1 \\ 2 \end{bmatrix} \right\}$.

(a) Sketch the four Euclidean vectors

$$1 \begin{bmatrix} 1 \\ 2 \end{bmatrix} = \begin{bmatrix} 1 \\ 2 \end{bmatrix}, \quad 3 \begin{bmatrix} 1 \\ 2 \end{bmatrix} = \begin{bmatrix} 3 \\ 6 \end{bmatrix}, \quad 0 \begin{bmatrix} 1 \\ 2 \end{bmatrix} = \begin{bmatrix} 0 \\ 0 \end{bmatrix}, \quad -2 \begin{bmatrix} 1 \\ 2 \end{bmatrix} = \begin{bmatrix} -2 \\ -4 \end{bmatrix}$$

in the xy plane by placing a dot at the (x, y) coordinate associated with each vector.

(b) Sketch a representation of all the vectors belonging to

$$\text{span} \left\{ \begin{bmatrix} 1 \\ 2 \end{bmatrix} \right\} = \left\{ a \begin{bmatrix} 1 \\ 2 \end{bmatrix} \mid a \in \mathbb{R} \right\}$$

in the xy plane by plotting their (x, y) coordinates as dots. What best describes this sketch?

A. A line

B. A plane

C. A parabola

D. A circle

Remark 2.1.6 It is important to remember that

$$\{\vec{v}_1, \vec{v}_2, \dots, \vec{v}_n\} \neq \text{span}\{\vec{v}_1, \vec{v}_2, \dots, \vec{v}_n\}.$$

For example,

$$\left\{ \begin{bmatrix} 1 \\ -1 \\ 2 \end{bmatrix}, \begin{bmatrix} 1 \\ 2 \\ 1 \end{bmatrix} \right\}$$

is a set containing exactly two vectors, while

$$\text{span} \left\{ \begin{bmatrix} 1 \\ -1 \\ 2 \end{bmatrix}, \begin{bmatrix} 1 \\ 2 \\ 1 \end{bmatrix} \right\} = \left\{ a \begin{bmatrix} 1 \\ -1 \\ 2 \end{bmatrix} + b \begin{bmatrix} 1 \\ 2 \\ 1 \end{bmatrix} \mid a, b \in \mathbb{R} \right\}$$

is a set containing infinitely-many vectors.

Activity 2.1.7 Consider $\text{span} \left\{ \begin{bmatrix} 1 \\ 2 \end{bmatrix}, \begin{bmatrix} -1 \\ 1 \end{bmatrix} \right\}$.

(a) Sketch the following five Euclidean vectors in the xy plane.

$$\begin{aligned} 1 \begin{bmatrix} 1 \\ 2 \end{bmatrix} + 0 \begin{bmatrix} -1 \\ 1 \end{bmatrix} &= ? & 0 \begin{bmatrix} 1 \\ 2 \end{bmatrix} + 1 \begin{bmatrix} -1 \\ 1 \end{bmatrix} &= ? & 1 \begin{bmatrix} 1 \\ 2 \end{bmatrix} + 1 \begin{bmatrix} -1 \\ 1 \end{bmatrix} &= ? \\ -2 \begin{bmatrix} 1 \\ 2 \end{bmatrix} + 1 \begin{bmatrix} -1 \\ 1 \end{bmatrix} &= ? & -1 \begin{bmatrix} 1 \\ 2 \end{bmatrix} + -2 \begin{bmatrix} -1 \\ 1 \end{bmatrix} &= ? \end{aligned}$$

(b) Sketch a representation of all the vectors belonging to

$$\text{span} \left\{ \begin{bmatrix} 1 \\ 2 \end{bmatrix}, \begin{bmatrix} -1 \\ 1 \end{bmatrix} \right\} = \left\{ a \begin{bmatrix} 1 \\ 2 \end{bmatrix} + b \begin{bmatrix} -1 \\ 1 \end{bmatrix} \mid a, b \in \mathbb{R} \right\}$$

in the xy plane. What best describes this sketch?

- A. A line B. A plane C. A parabola D. A circle

Activity 2.1.8 Sketch a representation of all the vectors belonging to $\text{span} \left\{ \begin{bmatrix} 6 \\ -4 \end{bmatrix}, \begin{bmatrix} -3 \\ 2 \end{bmatrix} \right\}$ in the xy plane. What best describes this sketch?

- A. A line
B. A plane
C. A parabola
D. A cube

Activity 2.1.9 Consider the following questions to discover whether a Euclidean vector belongs to a span.

(a) The Euclidean vector $\begin{bmatrix} -1 \\ -6 \\ 1 \end{bmatrix}$ belongs to $\text{span} \left\{ \begin{bmatrix} 1 \\ 0 \\ -3 \end{bmatrix}, \begin{bmatrix} -1 \\ -3 \\ 2 \end{bmatrix} \right\}$ exactly when

there exists a solution to which of these vector equations?

$$\begin{aligned} \text{A. } & x_1 \begin{bmatrix} -1 \\ -6 \\ 1 \end{bmatrix} + x_2 \begin{bmatrix} 1 \\ 0 \\ -3 \end{bmatrix} = \begin{bmatrix} -1 \\ -3 \\ 2 \end{bmatrix} \\ \text{B. } & x_1 \begin{bmatrix} 1 \\ 0 \\ -3 \end{bmatrix} + x_2 \begin{bmatrix} -1 \\ -3 \\ 2 \end{bmatrix} = \begin{bmatrix} -1 \\ -6 \\ 1 \end{bmatrix} \\ \text{C. } & x_1 \begin{bmatrix} -1 \\ -3 \\ 2 \end{bmatrix} + x_2 \begin{bmatrix} -1 \\ -6 \\ 1 \end{bmatrix} + x_3 \begin{bmatrix} 1 \\ 0 \\ -3 \end{bmatrix} = 0 \end{aligned}$$

(b) Use technology to find RREF of the corresponding augmented matrix, and then use that matrix to find the solution set of the vector equation.

(c) Given this solution set, does $\begin{bmatrix} -1 \\ -6 \\ 1 \end{bmatrix}$ belong to $\text{span} \left\{ \begin{bmatrix} 1 \\ 0 \\ -3 \end{bmatrix}, \begin{bmatrix} -1 \\ -3 \\ 2 \end{bmatrix} \right\}$?

Observation 2.1.10 The following are all equivalent statements:

- The vector \vec{b} belongs to $\text{span}\{\vec{v}_1, \dots, \vec{v}_n\}$.
- The vector \vec{b} is a linear combination of the vectors $\vec{v}_1, \dots, \vec{v}_n$.
- The vector equation $x_1\vec{v}_1 + \dots + x_n\vec{v}_n = \vec{b}$ is consistent.
- The linear system corresponding to $[\vec{v}_1 \dots \vec{v}_n | \vec{b}]$ is consistent.
- RREF $[\vec{v}_1 \dots \vec{v}_n | \vec{b}]$ doesn't have a row $[0 \dots 0 | 1]$ representing the contradiction $0 = 1$.

Activity 2.1.11 Consider this claim about a vector equation:

$$\begin{bmatrix} -6 \\ 2 \\ -6 \end{bmatrix} \text{ is a linear combination of the vectors } \begin{bmatrix} 1 \\ 0 \\ 2 \end{bmatrix}, \begin{bmatrix} 3 \\ 0 \\ 6 \end{bmatrix}, \begin{bmatrix} 2 \\ 0 \\ 4 \end{bmatrix}, \text{ and } \begin{bmatrix} -4 \\ 1 \\ -5 \end{bmatrix}.$$

(a) Write a statement involving the solutions of a vector equation that's equivalent to this claim.

(b) Explain why the statement you wrote is true.

(c) Since your statement was true, use the solution set to describe a linear combination of

$$\begin{bmatrix} 1 \\ 0 \\ 2 \end{bmatrix}, \begin{bmatrix} 3 \\ 0 \\ 6 \end{bmatrix}, \begin{bmatrix} 2 \\ 0 \\ 4 \end{bmatrix}, \text{ and } \begin{bmatrix} -4 \\ 1 \\ -5 \end{bmatrix} \text{ that equals } \begin{bmatrix} -6 \\ 2 \\ -6 \end{bmatrix}.$$

Activity 2.1.12 Consider this claim about a vector equation:

$$\begin{bmatrix} -5 \\ -1 \\ -7 \end{bmatrix} \text{ belongs to span } \left\{ \begin{bmatrix} 1 \\ 0 \\ 2 \end{bmatrix}, \begin{bmatrix} 3 \\ 0 \\ 6 \end{bmatrix}, \begin{bmatrix} 2 \\ 0 \\ 4 \end{bmatrix}, \begin{bmatrix} -4 \\ 1 \\ -5 \end{bmatrix} \right\}.$$

- (a) Write a statement involving the solutions of a vector equation that's equivalent to this claim.
- (b) Explain why the statement you wrote is false, to conclude that the vector does not belong to the span.

2.1.3 Individual Practice

Activity 2.1.13 Before next class, find some time to do the following:

- (a) Without referring to your activity book, write down the definition of a linear combination of vectors.

- (b) Let $\vec{u} = \begin{bmatrix} 1 \\ 2 \\ 0 \end{bmatrix}$ and $\vec{v} = \begin{bmatrix} -1 \\ 3 \\ 0 \end{bmatrix}$. Write down an example $\vec{w}_1 = \begin{bmatrix} ? \\ ? \\ ? \end{bmatrix}$ of a linear combination of \vec{u}, \vec{v} . Then write down an example $\vec{w}_2 = \begin{bmatrix} ? \\ ? \\ ? \end{bmatrix}$ that is *not* a linear combination of \vec{u}, \vec{v} .

- (c) Draw a rough sketch of the vectors $\vec{u} = \begin{bmatrix} 1 \\ 2 \\ 0 \end{bmatrix}$, $\vec{v} = \begin{bmatrix} -1 \\ 3 \\ 0 \end{bmatrix}$, $\vec{w}_1 = \begin{bmatrix} ? \\ ? \\ ? \end{bmatrix}$, and

$$\vec{w}_2 = \begin{bmatrix} ? \\ ? \\ ? \end{bmatrix} \text{ in } \mathbb{R}^3.$$

2.1.4 Videos

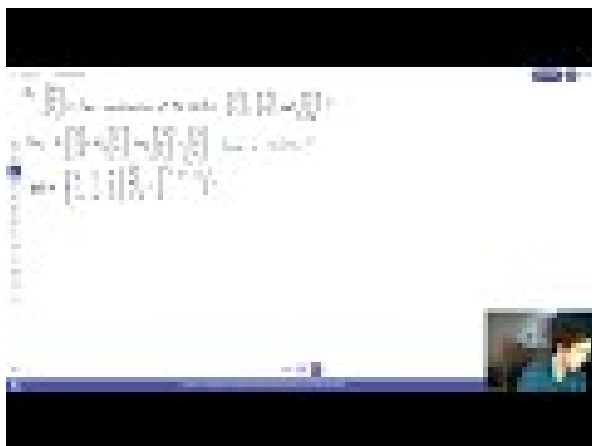

Figure 5 Video: Linear combinations



Standalone

2.1.5 Exercises

Exercises available at <https://tbil.org/linear-algebra/preview/exercises/#/bank/EV1/>.

2.1.6 Mathematical Writing Explorations

Exploration 2.1.14 Suppose $S = \{\vec{v}_1, \dots, \vec{v}_n\}$ is a set of vectors. Show that \vec{v}_0 is a linear combination of members of S , if and only if there are a set of scalars $\{c_0, c_1, \dots, c_n\}$ such that $\vec{z} = c_0\vec{v}_0 + \dots + c_n\vec{v}_n$. We can do this in a few parts. I've used bullets here to indicate all that needs to be done. This is an "if and only if" proof, so it needs two parts.

- First, assume that $\vec{0} = c_0\vec{v}_0 + \dots + c_n\vec{v}_n$ has a solution, with $c_0 \neq 0$. Show that \vec{v}_0 is a linear combination of elements of S .
- Next, assume that \vec{v}_0 is a linear combination of elements of S . Can you find the appropriate $\{c_0, c_1, \dots, c_n\}$ to make the equation $\vec{z} = c_0\vec{v}_0 + \dots + c_n\vec{v}_n$ true?
- In either of your proofs above, does the case when $\vec{v}_0 = \vec{z}$ change your thinking? Explain why or why not.

2.1.7 Sample Problem and Solution

Sample problem [Example B.1.5](#).

2.2 Spanning Sets (EV2)

Learning Outcomes

- Determine if a set of Euclidean vectors spans \mathbb{R}^n by solving appropriate vector equations.

2.2.1 Warm Up

Activity 2.2.1 Given a set of ingredients and a meal, a recipe is a list of amounts of each ingredient required to prepare the given meal.

- Use the words *vector* and *linear combination* to create a new statement that is analogous to one above.
- Building on your analogy, what role might the word *span* play?

2.2.2 Class Activities

Observation 2.2.2 Any single non-zero vector/number x in \mathbb{R}^1 spans \mathbb{R}^1 , since $\mathbb{R}^1 = \{cx \mid c \in \mathbb{R}\}$.

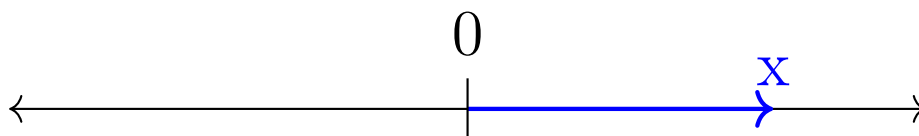

Figure 6 An \mathbb{R}^1 vector

Activity 2.2.3 How many vectors are required to span \mathbb{R}^2 ? Sketch a drawing in the xy plane to support your answer.

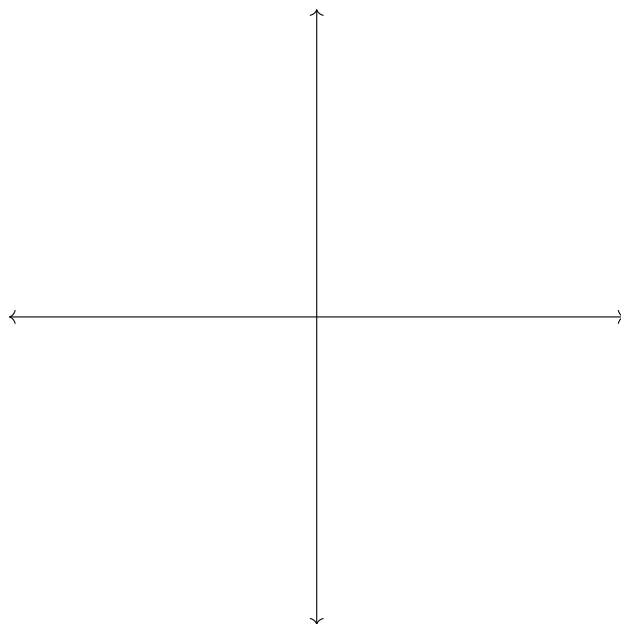

Figure 7 The xy plane \mathbb{R}^2

A. 1

D. 4

B. 2

C. 3

E. Infinitely Many

Activity 2.2.4 How many vectors are required to span \mathbb{R}^3 ?

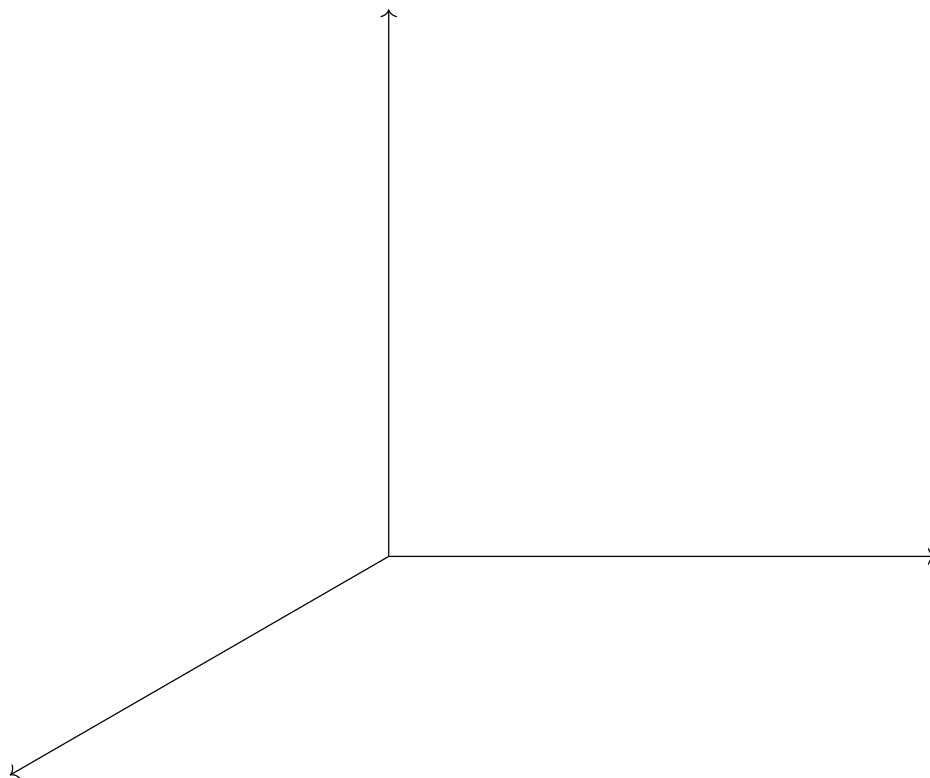

Figure 8 \mathbb{R}^3 space

A. 1

D. 4

B. 2

C. 3

E. Infinitely Many

Fact 2.2.5 *At least n vectors are required to span \mathbb{R}^n .*

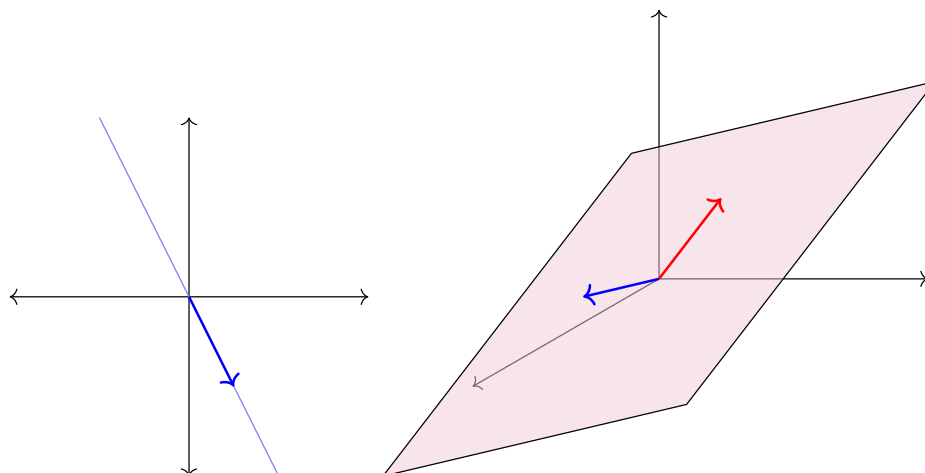

Figure 9 *Failed attempts to span \mathbb{R}^n by $< n$ vectors*

Activity 2.2.6 Consider the question: Does every vector in \mathbb{R}^3 belong to

$$\text{span} \left\{ \begin{bmatrix} 1 \\ -1 \\ 0 \end{bmatrix}, \begin{bmatrix} -2 \\ 0 \\ 1 \end{bmatrix}, \begin{bmatrix} -2 \\ -2 \\ 2 \end{bmatrix} \right\}?$$

(a) Determine if $\begin{bmatrix} 7 \\ -3 \\ -2 \end{bmatrix}$ belongs to $\text{span} \left\{ \begin{bmatrix} 1 \\ -1 \\ 0 \end{bmatrix}, \begin{bmatrix} -2 \\ 0 \\ 1 \end{bmatrix}, \begin{bmatrix} -2 \\ -2 \\ 2 \end{bmatrix} \right\}$.

(b) Determine if $\begin{bmatrix} 0 \\ -4 \\ 3 \end{bmatrix}$ belongs to $\text{span} \left\{ \begin{bmatrix} 1 \\ -1 \\ 0 \end{bmatrix}, \begin{bmatrix} -2 \\ 0 \\ 1 \end{bmatrix}, \begin{bmatrix} -2 \\ -2 \\ 2 \end{bmatrix} \right\}$.

(c) Determine if $\begin{bmatrix} 2 \\ 5 \\ 7 \end{bmatrix}$ belongs to $\text{span} \left\{ \begin{bmatrix} 1 \\ -1 \\ 0 \end{bmatrix}, \begin{bmatrix} -2 \\ 0 \\ 1 \end{bmatrix}, \begin{bmatrix} -2 \\ -2 \\ 2 \end{bmatrix} \right\}$.

Activity 2.2.7 We'd prefer a more methodical method to decide if every vector in \mathbb{R}^n belongs to some spanning set, compared to the guess-and-check method we used in [Activity 2.2.6](#).

(a) An arbitrary vector $\begin{bmatrix} ? \\ ? \\ ? \end{bmatrix}$ belongs to $\text{span} \left\{ \begin{bmatrix} 1 \\ -1 \\ 0 \end{bmatrix}, \begin{bmatrix} -2 \\ 0 \\ 1 \end{bmatrix}, \begin{bmatrix} -2 \\ -2 \\ 2 \end{bmatrix} \right\}$ provided the equation

$$x_1 \begin{bmatrix} 1 \\ -1 \\ 0 \end{bmatrix} + x_2 \begin{bmatrix} -2 \\ 0 \\ 1 \end{bmatrix} + x_3 \begin{bmatrix} -2 \\ -2 \\ 2 \end{bmatrix} = \begin{bmatrix} ? \\ ? \\ ? \end{bmatrix}$$

has...

- A. no solutions.
 - B. exactly one solution.
 - C. at least one solution.
 - D. infinitely-many solutions.
- (b) We're guaranteed at least one solution if the RREF of the corresponding augmented matrix has no contradictions; likewise, we have no solutions if the RREF corresponds to the contradiction $0 = 1$. Given

$$\left[\begin{array}{ccc|c} 1 & -2 & -2 & ? \\ -1 & 0 & -2 & ? \\ 0 & 1 & 2 & ? \end{array} \right] \sim \left[\begin{array}{ccc|c} 1 & 0 & 2 & ? \\ 0 & 1 & 2 & ? \\ 0 & 0 & 0 & ? \end{array} \right]$$

we may conclude that the set does not span all of \mathbb{R}^3 because...

- A. the row $[0 \ 1 \ 2 \ | \ ?]$ prevents a contradiction.
- B. the row $[0 \ 1 \ 2 \ | \ ?]$ allows a contradiction.
- C. the row $[0 \ 0 \ 0 \ | \ ?]$ prevents a contradiction.
- D. the row $[0 \ 0 \ 0 \ | \ ?]$ allows a contradiction.

Fact 2.2.8 The set $\{\vec{v}_1, \dots, \vec{v}_n\}$ spans all of \mathbb{R}^n exactly when the vector equation

$$x_1\vec{v}_1 + \dots + x_n\vec{v}_n = \vec{w}$$

is consistent for every vector \vec{w} .

Likewise, the set $\{\vec{v}_1, \dots, \vec{v}_n\}$ fails to span all of \mathbb{R}^n exactly when the vector equation

$$x_1\vec{v}_1 + \dots + x_n\vec{v}_n = \vec{w}$$

is inconsistent for some vector \vec{w} .

Note these two possibilities are decided based on whether or not the RREF of the vector equation's coefficient matrix (that is, $\text{RREF}[\vec{v}_1 \dots \vec{v}_n]$) has either all pivot rows, or at least one non-pivot row (a row of zeroes):

$$\begin{bmatrix} 1 & -2 & -2 \\ -1 & 0 & -2 \\ 0 & 1 & 2 \end{bmatrix} \sim \begin{bmatrix} 1 & 0 & 2 \\ 0 & 1 & 2 \\ 0 & 0 & 0 \end{bmatrix}.$$

Activity 2.2.9 Consider the set of vectors $S = \left\{ \begin{bmatrix} 2 \\ 3 \\ 0 \\ -1 \end{bmatrix}, \begin{bmatrix} 1 \\ -4 \\ 3 \\ 0 \end{bmatrix}, \begin{bmatrix} 1 \\ 7 \\ -3 \\ -1 \end{bmatrix}, \begin{bmatrix} 0 \\ 3 \\ 5 \\ 7 \end{bmatrix}, \begin{bmatrix} 3 \\ 13 \\ 7 \\ 16 \end{bmatrix} \right\}$ and the question “Does $\mathbb{R}^4 = \text{span } S$?”

(a) Rewrite this question in terms of the solutions to a vector equation.

(b) Answer your new question, and use this to answer the original question.

Activity 2.2.10 Let $\vec{v}_1, \vec{v}_2, \vec{v}_3 \in \mathbb{R}^7$ be three Euclidean vectors, and suppose \vec{w} is another vector with $\vec{w} \in \text{span}\{\vec{v}_1, \vec{v}_2, \vec{v}_3\}$. What can you conclude about $\text{span}\{\vec{w}, \vec{v}_1, \vec{v}_2, \vec{v}_3\}$?

- A. $\text{span}\{\vec{w}, \vec{v}_1, \vec{v}_2, \vec{v}_3\}$ is larger than $\text{span}\{\vec{v}_1, \vec{v}_2, \vec{v}_3\}$.
- B. $\text{span}\{\vec{w}, \vec{v}_1, \vec{v}_2, \vec{v}_3\}$ is the same as $\text{span}\{\vec{v}_1, \vec{v}_2, \vec{v}_3\}$.
- C. $\text{span}\{\vec{w}, \vec{v}_1, \vec{v}_2, \vec{v}_3\}$ is smaller than $\text{span}\{\vec{v}_1, \vec{v}_2, \vec{v}_3\}$.

2.2.3 Individual Practice

Activity 2.2.11 One of our important results in this lesson is [Fact 2.2.5](#), which states that a set of n vectors is required to span \mathbb{R}^n . While we developed some geometric intuition for why this true, we did not prove it in class. Before coming to class next time, follow the steps outlined below to convince yourself of this fact using the concepts we learned in this lesson.

- (a) Let $\{\vec{v}_1, \dots, \vec{v}_n\}$ be a set of vectors living in \mathbb{R}^n and assume that $m < n$. How many rows and how many columns will the matrix $[\vec{v}_1 \dots \vec{v}_n]$ have?
- (b) Given no additional information about the vectors $\vec{v}_1, \dots, \vec{v}_n$, what is the maximum possible number of pivots in $\text{RREF}[\vec{v}_1 \dots \vec{v}_n]$?

(c) Conclude that our given set of vector cannot span all of \mathbb{R}^n .

2.2.4 Videos



Standalone

Figure 10 Video: Determining if a set spans a Euclidean space

2.2.5 Exercises

Exercises available at <https://tbil.org/linear-algebra/preview/exercises/#/bank/EV2/>.

2.2.6 Mathematical Writing Explorations

Exploration 2.2.12 Construct each of the following, or show that it is impossible:

- A set of 2 vectors that spans \mathbb{R}^3
- A set of 3 vectors that spans \mathbb{R}^3
- A set of 3 vectors that does not span \mathbb{R}^3
- A set of 4 vectors that spans \mathbb{R}^3

For any of the sets you constructed that did span the required vector space, are any of the vectors a linear combination of the others in your set?

Exploration 2.2.13 Based on these results, generalize this a conjecture about how a set of $n - 1, n$ and $n + 1$ vectors would or would not span \mathbb{R}^n .

2.2.7 Sample Problem and Solution

Sample problem [Example B.1.6](#).

2.3 Subspaces (EV3)

Learning Outcomes

- Determine if a subset of \mathbb{R}^n is a subspace or not.

2.3.1 Warm Up

Activity 2.3.1 Consider the linear equation

$$x + 2y + z = 0.$$

(a) Verify that both $\vec{v} = \begin{bmatrix} 1 \\ -1 \\ 1 \end{bmatrix}$ and $\vec{w} = \begin{bmatrix} 1 \\ 0 \\ -1 \end{bmatrix}$ are solutions.

(b) Is the vector $2\vec{v} - 3\vec{w}$ also a solution?

2.3.2 Class Activities

Observation 2.3.2 Recall that if $S = \{\vec{v}_1, \dots, \vec{v}_n\}$ is subset of vectors in \mathbb{R}^n , then $\text{span}(S)$ is the set of all linear combinations of vectors in S . In EV2 ([Section 2.2](#)), we learned how to decide whether $\text{span}(S)$ was equal to all of \mathbb{R}^n or something strictly smaller.

Activity 2.3.3 Let S denote a set of vectors in \mathbb{R}^n and suppose that $\vec{u}, \vec{v} \in \text{span}(S)$, $c \in \mathbb{R}$ and that $\vec{w} \in \mathbb{R}^n$. Which of the following vectors might *not* belong to $\text{span}(S)$?

- A. $\vec{0}$
- B. $\vec{u} + \vec{w}$
- C. $\vec{u} + \vec{v}$
- D. $c\vec{u}$

Definition 2.3.4 A **homogeneous** system of linear equations is one of the form:

$$\begin{array}{cccc} a_{11}x_1 + a_{12}x_2 + \dots + a_{1n}x_n & = & 0 & \\ a_{21}x_1 + a_{22}x_2 + \dots + a_{2n}x_n & = & 0 & \\ \vdots & & \vdots & \vdots \\ a_{m1}x_1 + a_{m2}x_2 + \dots + a_{mn}x_n & = & 0 & \end{array}$$

This system is equivalent to the vector equation:

$$x_1\vec{v}_1 + \dots + x_n\vec{v}_n = \vec{0}$$

and the augmented matrix:

$$\left[\begin{array}{cccc|c} a_{11} & a_{12} & \cdots & a_{1n} & 0 \\ a_{21} & a_{22} & \cdots & a_{2n} & 0 \\ \vdots & \vdots & \ddots & \vdots & \vdots \\ a_{m1} & a_{m2} & \cdots & a_{mn} & 0 \end{array} \right]$$

◇

Activity 2.3.5 Consider the homogeneous vector equation $x_1\vec{v}_1 + \cdots + x_n\vec{v}_n = \vec{0}$.

(a) Is this equation consistent?

- A. no.
- B. yes.
- C. more information is required.

(b) Note that if $\begin{bmatrix} a_1 \\ \vdots \\ a_n \end{bmatrix}$ and $\begin{bmatrix} b_1 \\ \vdots \\ b_n \end{bmatrix}$ are both solutions, we know that

$$a_1\vec{v}_1 + \cdots + a_n\vec{v}_n = \vec{0} \text{ and } b_1\vec{v}_1 + \cdots + b_n\vec{v}_n = \vec{0}.$$

Therefore by adding these equations:

$$(a_1 + b_1)\vec{v}_1 + \cdots + (a_n + b_n)\vec{v}_n = \vec{0},$$

we may conclude that the vector $\begin{bmatrix} a_1 + b_1 \\ \vdots \\ a_n + b_n \end{bmatrix}$ is...

- A. another solution.
- B. not a solution.
- C. is equal to $\vec{0}$.

(c) Similarly, if $c \in \mathbb{R}$, then since multiplying by c yields:

$$(ca_1)\vec{v}_1 + \cdots + (ca_n)\vec{v}_n = \vec{0},$$

we may conclude that the vector $\begin{bmatrix} ca_1 \\ \vdots \\ ca_n \end{bmatrix}$ is...

- A. another solution.
- B. not a solution.
- C. is equal to $\vec{0}$.
- D. The empty set.

Observation 2.3.6 If S is any set of vectors in \mathbb{R}^n , then the set $\text{span}(S)$ has the following properties:

- the set $\text{span}(S)$ is non-empty.
- the set $\text{span}(S)$ is closed under addition: for any $\vec{u}, \vec{v} \in \text{span}(S)$, the sum $\vec{u} + \vec{v}$ is also in $\text{span}(S)$.
- the set $\text{span}(S)$ is closed under scalar multiplication: for any $\vec{u} \in \text{span}(S)$ and scalar $c \in \mathbb{R}$, the product $c\vec{u}$ is also in $\text{span}(S)$.

Likewise, if W is the solution set to a homogenous vector equation, it too satisfies:

- the set W is non-empty.
- the set W is closed under addition: for any $\vec{u}, \vec{v} \in W$, the sum $\vec{u} + \vec{v}$ is also in W .
- the set $\text{span}(S)$ is closed under scalar multiplication: for any $\vec{u} \in W$ and scalar $c \in \mathbb{R}$, the product $c\vec{u}$ is also in W .

Definition 2.3.7 A subset W of a vector space is called a **subspace** provided that it satisfies the following properties:

- the subset is non-empty.
- the subset is **closed under addition**: for any $\vec{u}, \vec{v} \in W$, the sum $\vec{u} + \vec{v}$ is also in W .
- the subset is **closed under scalar multiplication**: for any $\vec{u} \in W$ and scalar $c \in \mathbb{R}$, the product $c\vec{u}$ is also in W .

◇

Observation 2.3.8 Note the similarities between a planar subspace spanned by two non-colinear vectors in \mathbb{R}^3 , and the Euclidean plane \mathbb{R}^2 . While they are not the same thing (and shouldn't be referred to interchangeably), algebraists call such similar spaces **isomorphic**; we'll learn what this means more carefully in a later chapter.

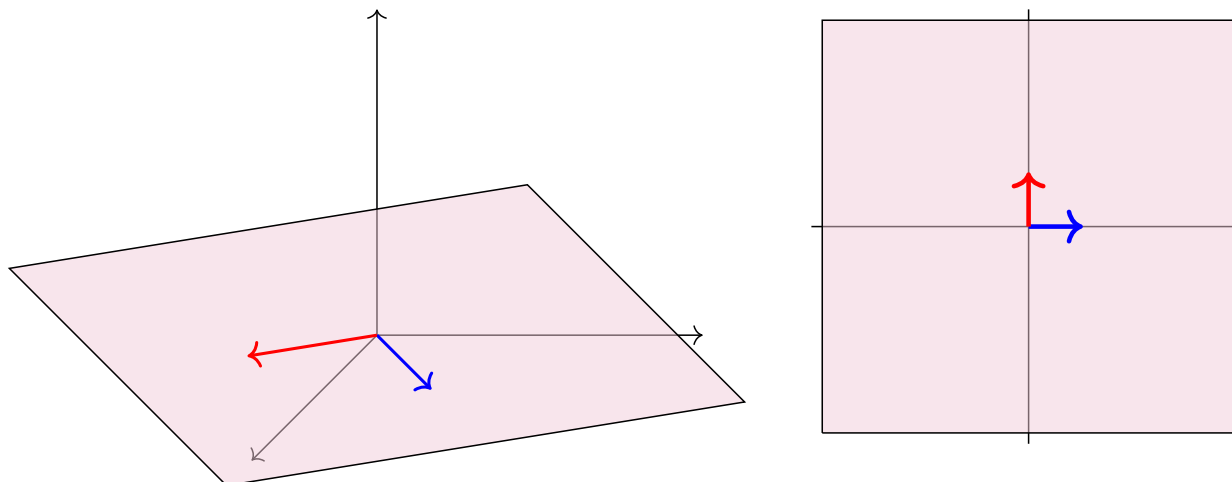

Figure 11 A planar subset of \mathbb{R}^3 compared with the plane \mathbb{R}^2 .

Activity 2.3.9 Let $W = \left\{ \begin{bmatrix} x \\ y \\ z \end{bmatrix} \mid x + 2y + z = 0 \right\}$.

(a) Is W the empty set?

(b) Let's assume that $\vec{v} = \begin{bmatrix} x \\ y \\ z \end{bmatrix}$ and $\vec{w} = \begin{bmatrix} a \\ b \\ c \end{bmatrix}$ are in W . What are we allowed to assume?

A. $x + 2y + z = 0$.

C. Both of these.

B. $a + 2b + c = 0$.

D. Neither of these.

(c) Which equation must be verified to show that $\vec{v} + \vec{w} = \begin{bmatrix} x + a \\ y + b \\ z + c \end{bmatrix}$ also belongs to W ?

A. $(x + a) + 2(y + b) + (z + c) = 0$.

B. $x + a + 2y + b + z + c = 0$.

C. $x + 2y + z = a + 2b + c$.

(d) Use the assumptions from (a) to verify the equation from (b).

(e) Is W a subspace of \mathbb{R}^3 ?

A. Yes

B. No

C. Not enough information

(f) Show that $k\vec{v} = \begin{bmatrix} kx \\ ky \\ kz \end{bmatrix}$ also belongs to W for any $k \in \mathbb{R}$ by verifying $(kx) + 2(ky) + (kz) = 0$ under these assumptions.

(g) Is W is a subspace of \mathbb{R}^3 ?

A. Yes

B. No

C. Not enough information

Activity 2.3.10 Let $W = \left\{ \begin{bmatrix} x \\ y \\ z \end{bmatrix} \mid x + 2y + z = 4 \right\}$.

(a) Is W the empty set?

(b) Which of these statements is valid?

A. $\begin{bmatrix} 1 \\ 1 \\ 1 \end{bmatrix} \in W$, and $\begin{bmatrix} 2 \\ 2 \\ 2 \end{bmatrix} \in W$, so W is a subspace.

B. $\begin{bmatrix} 1 \\ 1 \\ 1 \end{bmatrix} \in W$, and $\begin{bmatrix} 2 \\ 2 \\ 2 \end{bmatrix} \in W$, so W is not a subspace.

C. $\begin{bmatrix} 1 \\ 1 \\ 1 \end{bmatrix} \in W$, but $\begin{bmatrix} 2 \\ 2 \\ 2 \end{bmatrix} \notin W$, so W is a subspace.

D. $\begin{bmatrix} 1 \\ 1 \\ 1 \end{bmatrix} \in W$, but $\begin{bmatrix} 2 \\ 2 \\ 2 \end{bmatrix} \notin W$, so W is not a subspace.

(c) Which of these statements is valid?

(a) $\begin{bmatrix} 1 \\ 1 \\ 1 \end{bmatrix} \in W$, and $\begin{bmatrix} 0 \\ 0 \\ 0 \end{bmatrix} \in W$, so W is a subspace.

(b) $\begin{bmatrix} 1 \\ 1 \\ 1 \end{bmatrix} \in W$, and $\begin{bmatrix} 0 \\ 0 \\ 0 \end{bmatrix} \in W$, so W is not a subspace.

(c) $\begin{bmatrix} 1 \\ 1 \\ 1 \end{bmatrix} \in W$, but $\begin{bmatrix} 0 \\ 0 \\ 0 \end{bmatrix} \notin W$, so W is a subspace.

(d) $\begin{bmatrix} 1 \\ 1 \\ 1 \end{bmatrix} \in W$, but $\begin{bmatrix} 0 \\ 0 \\ 0 \end{bmatrix} \notin W$, so W is not a subspace.

Remark 2.3.11 In summary, *any one* of the following is enough to prove that a nonempty subset W is *not* a subspace:

- Find specific values for $\vec{u}, \vec{v} \in W$ such that $\vec{u} + \vec{v} \notin W$.

- Find specific values for $c \in \mathbb{R}$, $\vec{v} \in W$ such that $c\vec{v} \notin W$.
- Show that $\vec{0} \notin W$.

If you cannot do any of these, then W can be proven to be a subspace by doing *all* of the following:

1. Show that W is non-empty.
2. For all $\vec{v}, \vec{w} \in W$ (not just specific values), $\vec{u} + \vec{v} \in W$.
3. For all $\vec{v} \in W$ and $c \in \mathbb{R}$ (not just specific values), $c\vec{v} \in W$.

Activity 2.3.12 Consider these subsets of \mathbb{R}^3 :

$$R = \left\{ \begin{bmatrix} x \\ y \\ z \end{bmatrix} \middle| y = z + 1 \right\} \quad S = \left\{ \begin{bmatrix} x \\ y \\ z \end{bmatrix} \middle| y = |z| \right\} \quad T = \left\{ \begin{bmatrix} x \\ y \\ z \end{bmatrix} \middle| z = xy \right\}.$$

- (a) Show R isn't a subspace by showing that $\vec{0} \notin R$.
- (b) Show S isn't a subspace by finding two vectors $\vec{u}, \vec{v} \in S$ such that $\vec{u} + \vec{v} \notin S$.
- (c) Show T isn't a subspace by finding a vector $\vec{v} \in T$ such that $2\vec{v} \notin T$.

Activity 2.3.13 Consider the following two sets of Euclidean vectors:

$$U = \left\{ \begin{bmatrix} x \\ y \end{bmatrix} \middle| 7x + 4y = 0 \right\} \quad W = \left\{ \begin{bmatrix} x \\ y \end{bmatrix} \middle| 3xy^2 = 0 \right\}$$

Explain why one of these sets is a subspace of \mathbb{R}^2 and one is not.

Activity 2.3.14 Consider the following attempted proof that

$$U = \left\{ \begin{bmatrix} x \\ y \end{bmatrix} \middle| x + y = xy \right\}$$

is closed under scalar multiplication.

Let $\begin{bmatrix} x \\ y \end{bmatrix} \in U$, so we know that $x + y = xy$. We want to show $k \begin{bmatrix} x \\ y \end{bmatrix} = \begin{bmatrix} kx \\ ky \end{bmatrix} \in U$, that is, $(kx) + (ky) = (kx)(ky)$. This is verified by the following calculation:

$$\begin{aligned} (kx) + (ky) &= (kx)(ky) \\ k(x + y) &= k^2xy \\ 0[k(x + y)] &= 0[k^2xy] \\ 0 &= 0 \end{aligned}$$

Is this reasoning valid?

A. Yes

B. No

Remark 2.3.15 Proofs of an equality $\text{LEFT} = \text{RIGHT}$ should generally be of one of these forms:

- Using a chain of equalities:

$$\begin{aligned} \text{LEFT} &= \dots \\ &= \dots \\ &= \dots \\ &= \text{RIGHT} \end{aligned}$$

Alternatively:

$$\begin{array}{ll} \text{LEFT} = \dots & \text{RIGHT} = \dots \\ = \dots & = \dots \\ = \dots & = \dots \\ = \text{SAME} & = \text{SAME} \end{array}$$

- When the assumption $\text{THIS} = \text{THAT}$ is already known or assumed to be true :

$$\begin{array}{ll} & \text{THIS} = \text{THAT} \\ \Rightarrow & \dots = \dots \\ \Rightarrow & \dots = \dots \\ \Rightarrow & \text{LEFT} = \text{RIGHT} \end{array}$$

Warning 2.3.16 The following proof is *invalid*.

$$\begin{array}{ll} & \text{LEFT} = \text{RIGHT} \\ \Rightarrow & \dots = \dots \\ \Rightarrow & \dots = \dots \\ \Rightarrow & 0 = 0 \\ \Rightarrow & \text{ANYTHING} = \text{ANYTHING} \end{array}$$

Basically, you cannot prove something is true by assuming it's true, and it's not helpful to prove to someone that zero equals itself (they probably already know that).

2.3.3 Individual Practice

Remark 2.3.17 Recall that in [Activity 2.2.1](#) we used the words *vector*, *linear combination*, and *span* to make an analogy with recipes, ingredients, and meals. In this analogy, a *recipe* was defined to be a list of amounts of each ingredient to build a particular meal.

Activity 2.3.18

- (a) Given the set of ingredients $S = \{\text{flour, yeast, salt, water, sugar, milk}\}$, how should we think of the subspace $\text{span}(S)$?
- (b) What is one meal that lives in the subspace $\text{span}(S)$?
- (c) What is one meal that does not live in the subspace $\text{span}(S)$?

Activity 2.3.19 Let

$$W = \left\{ \begin{bmatrix} x \\ y \\ z \\ w \end{bmatrix} \mid x + y = 3z + 2w \right\}.$$

The set W is a subspace. Below are two attempted proofs of the fact that W is closed under vector addition. Both of them are invalid; explain why.

- (a) Let $\vec{u} = \begin{bmatrix} 1 \\ 4 \\ 1 \\ 1 \end{bmatrix}$, $\vec{v} = \begin{bmatrix} 2 \\ -1 \\ 1 \\ -1 \end{bmatrix}$. Then both \vec{u}, \vec{v} are elements of W . Their sum is

$$\vec{w} = \begin{bmatrix} 3 \\ 3 \\ 2 \\ 0 \end{bmatrix}$$

and since

$$3 + 3 = 3 \cdot (2) + 2 \cdot (0),$$

it follows that \vec{w} is also in W and so W is closed under vector addition.

- (b) If $\begin{bmatrix} x \\ y \\ z \\ w \end{bmatrix}$, $\begin{bmatrix} a \\ b \\ c \\ d \end{bmatrix}$ are in W , we need to show that $\begin{bmatrix} x + a \\ y + b \\ z + c \\ w + d \end{bmatrix}$ is also in W . To be in W , we need

$$(x + a) + (y + b) = 3(z + c) + 2(w + d).$$

Well, if

$$(x + a) + (y + b) = 3(z + c) + 2(w + d),$$

then we know that

$$x + y - 3z - 2w + a + b - 3c - 2d = 0$$

by moving everything over to the left hand side. Since we are assuming that $x + y - 3z - 2w = 0$ and $a + b - 3c - 2d = 0$, it follows that $0 = 0$, which is true, which proves that vector addition is closed.

2.3.4 Videos



Standalone

Figure 12 Video: Showing that a subset of a vector space is a subspace

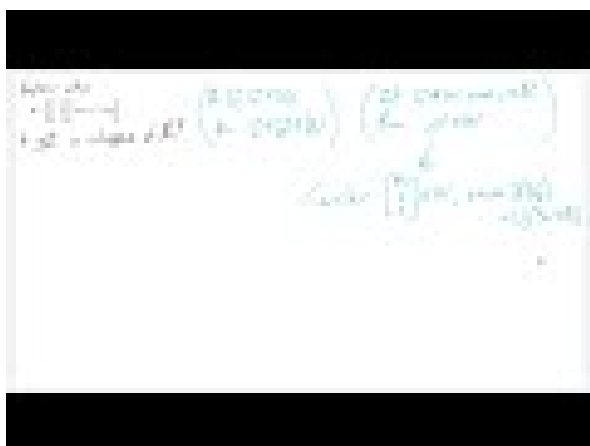

Standalone

Figure 13 Video: Showing that a subset of a vector space is not a subspace

2.3.5 Exercises

Exercises available at <https://tbil.org/linear-algebra/preview/exercises/#/bank/EV3/>.

2.3.6 Mathematical Writing Explorations

Exploration 2.3.20 A square matrix M is **symmetric** if, for each index i, j , the entries $m_{ij} = m_{ji}$. That is, the matrix is itself when reflected over the diagonal from upper left to lower right. Prove that the set of $n \times n$ symmetric matrices is a subspace of $M_{n \times n}$.

Exploration 2.3.21 The space of all real-valued function of one real variable is a vector space. First, define \oplus and \odot for this vector space. Check that you have closure (both kinds!) and show what the zero vector is under your chosen addition. Decide if each of the following is a subspace. If so, prove it. If not, provide the counterexample.

- The set of even functions, $\{f : \mathbb{R} \rightarrow \mathbb{R} : f(-x) = f(x) \text{ for all } x\}$.

- The set of odd functions, $\{f : \mathbb{R} \rightarrow \mathbb{R} : f(-x) = -f(x) \text{ for all } x\}$.

Exploration 2.3.22 Give an example of each of these, or explain why it's not possible that such a thing would exist.

- A nonempty subset of $M_{2 \times 2}$ that is not a subspace.
- A set of two vectors in \mathbb{R}^2 that is not a spanning set.

Exploration 2.3.23 Let V be a vector space and $S = \{\vec{v}_1, \vec{v}_2, \dots, \vec{v}_n\}$ a subset of V . Show that the span of S is a subspace. Is it possible that there is a subset of V containing fewer vectors than S , but whose span contains all of the vectors in the span of S ?

2.3.7 Sample Problem and Solution

Sample problem [Example B.1.7](#).

2.4 Linear Independence (EV4)

Learning Outcomes

- Determine if a set of Euclidean vectors is linearly dependent or independent by solving an appropriate vector equation.

2.4.1 Warm Up

Activity 2.4.1 Consider the vector equation

$$x_1 \begin{bmatrix} 1 \\ 1 \\ 1 \end{bmatrix} + x_2 \begin{bmatrix} 2 \\ 0 \\ -1 \end{bmatrix} + x_3 \begin{bmatrix} -1 \\ 2 \\ 0 \end{bmatrix} = \begin{bmatrix} -1 \\ 7 \\ 6 \end{bmatrix}.$$

(a) Decide which of $\begin{bmatrix} 3 \\ -1 \\ 2 \end{bmatrix}$ or $\begin{bmatrix} 1 \\ 1 \\ 1 \end{bmatrix}$ is a solution vector.

(b) Consider now the following vector equation:

$$y_1 \begin{bmatrix} 1 \\ 1 \\ 1 \end{bmatrix} + y_2 \begin{bmatrix} 2 \\ 0 \\ -1 \end{bmatrix} + y_3 \begin{bmatrix} -1 \\ 2 \\ 0 \end{bmatrix} + y_4 \begin{bmatrix} -1 \\ 7 \\ 6 \end{bmatrix} = \vec{0}.$$

How is this vector equation related to the original one?

(c) Use the solution vector you found in part (a) to construct a solution vector to this new equation.

2.4.2 Class Activities

Activity 2.4.2 Consider the two sets

$$S = \left\{ \begin{bmatrix} 2 \\ 3 \\ 1 \end{bmatrix}, \begin{bmatrix} 1 \\ 1 \\ 4 \end{bmatrix} \right\} \quad T = \left\{ \begin{bmatrix} 2 \\ 3 \\ 1 \end{bmatrix}, \begin{bmatrix} 1 \\ 1 \\ 4 \end{bmatrix}, \begin{bmatrix} -1 \\ 0 \\ -11 \end{bmatrix} \right\}.$$

Which of the following is true?

- A. span S is bigger than span T .
- B. span S and span T are the same size.
- C. span S is smaller than span T .

Definition 2.4.3 We say that a set of vectors is **linearly dependent** if one vector in the set belongs to the span of the others. Otherwise, we say the set is **linearly independent**.

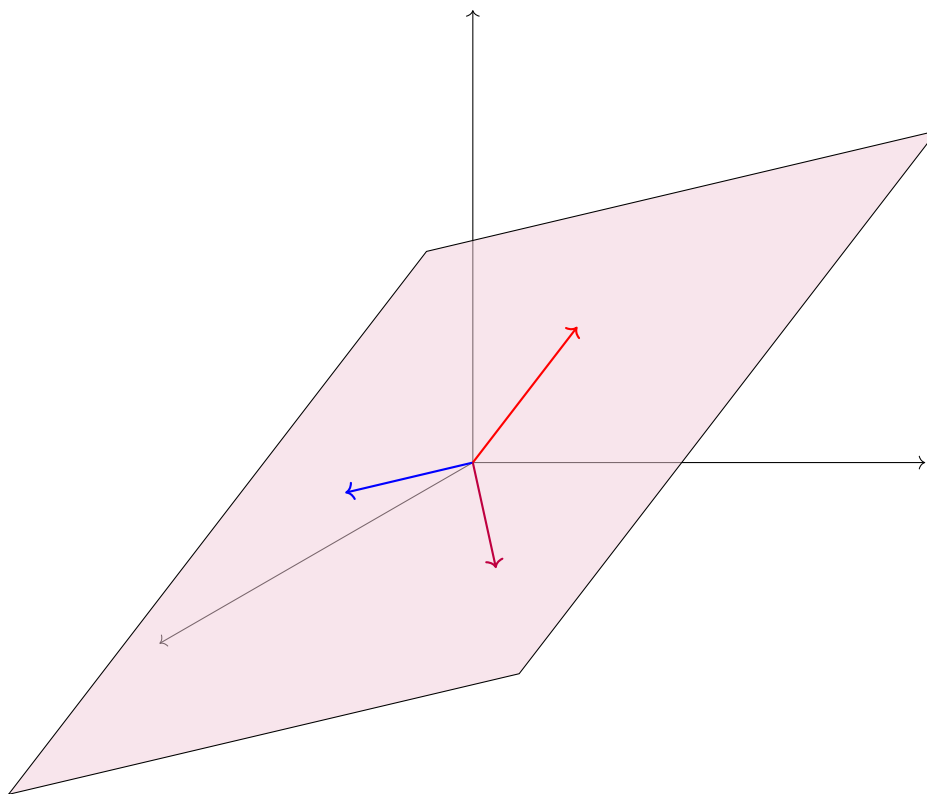

Figure 14 A linearly dependent set of three vectors

You can think of linearly dependent sets as containing a redundant vector, in the sense that you can drop a vector out without reducing the span of the set. In the above image, all three vectors lay in the same planar subspace, but only two vectors are needed to span the plane, so the set is linearly dependent. \diamond

Activity 2.4.4 Consider the following three vectors in \mathbb{R}^3 :

$$\vec{v}_1 = \begin{bmatrix} -2 \\ 0 \\ 0 \end{bmatrix}, \vec{v}_2 = \begin{bmatrix} 1 \\ 3 \\ 0 \end{bmatrix}, \text{ and } \vec{v}_3 = \begin{bmatrix} -2 \\ 5 \\ 4 \end{bmatrix}.$$

(a) Let $\vec{w} = 3\vec{v}_1 - \vec{v}_2 - 5\vec{v}_3 = \begin{bmatrix} ? \\ ? \\ ? \end{bmatrix}$. The set $\{\vec{v}_1, \vec{v}_2, \vec{v}_3, \vec{w}\}$ is...

- A. linearly dependent: at least one vector is a linear combination of others
- B. linearly independent: no vector is a linear combination of others

(b) Find

$$\text{RREF} \begin{bmatrix} \vec{v}_1 & \vec{v}_2 & \vec{v}_3 & \vec{w} \end{bmatrix} = \text{RREF} \begin{bmatrix} -2 & 1 & -2 & ? \\ 0 & 3 & 5 & ? \\ 0 & 0 & 4 & ? \end{bmatrix} = ?.$$

What does this tell you about solution set for the vector equation $x_1\vec{v}_1 + x_2\vec{v}_2 + x_3\vec{v}_3 + x_4\vec{w} = \vec{0}$?

- A. It is inconsistent.
- B. It is consistent with one solution.
- C. It is consistent with infinitely many solutions.

(c) Which of these might explain the connection?

- A. A pivot column establishes linear independence and creates a contradiction.
- B. A non-pivot column both describes a linear combination and reveals the number of solutions.
- C. A pivot row describes the bound variables and prevents a contradiction.
- D. A non-pivot row prevents contradictions and makes the vector equation solvable.

Fact 2.4.5 For any vector space, the set $\{\vec{v}_1, \dots, \vec{v}_n\}$ is linearly dependent if and only if the vector equation $x_1\vec{v}_1 + x_2\vec{v}_2 + \dots + x_n\vec{v}_n = \vec{0}$ is consistent with infinitely many solutions.

Likewise, the set of vectors $\{\vec{v}_1, \dots, \vec{v}_n\}$ is linearly independent if and only if the vector equation

$$x_1\vec{v}_1 + x_2\vec{v}_2 + \dots + x_n\vec{v}_n = \vec{0}$$

has exactly one solution: $\begin{bmatrix} x_1 \\ \vdots \\ x_n \end{bmatrix} = \begin{bmatrix} 0 \\ \vdots \\ 0 \end{bmatrix}$.

Activity 2.4.6 Find

$$\text{RREF} \left[\begin{array}{cccc|c} 2 & 2 & 3 & -1 & 4 & 0 \\ 3 & 0 & 13 & 10 & 3 & 0 \\ 0 & 0 & 7 & 7 & 0 & 0 \\ -1 & 3 & 16 & 14 & 1 & 0 \end{array} \right]$$

and mark the part of the matrix that demonstrates that

$$S = \left\{ \left(\begin{bmatrix} 2 \\ 3 \\ 0 \\ -1 \end{bmatrix}, \begin{bmatrix} 2 \\ 0 \\ 0 \\ 3 \end{bmatrix}, \begin{bmatrix} 3 \\ 13 \\ 7 \\ 16 \end{bmatrix}, \begin{bmatrix} -1 \\ 10 \\ 7 \\ 14 \end{bmatrix}, \begin{bmatrix} 4 \\ 3 \\ 0 \\ 1 \end{bmatrix} \right) \right\}$$

is linearly dependent (the part that shows its linear system has infinitely many solutions).

Observation 2.4.7 Compare the following results:

- A set of \mathbb{R}^m vectors $\{\vec{v}_1, \dots, \vec{v}_n\}$ is linearly independent if and only if $\text{RREF} [\vec{v}_1 \ \dots \ \vec{v}_n]$ has all pivot *columns*.
- A set of \mathbb{R}^m vectors $\{\vec{v}_1, \dots, \vec{v}_n\}$ is linearly dependent if and only if $\text{RREF} [\vec{v}_1 \ \dots \ \vec{v}_n]$ has at least one non-pivot *column*.
- A set of \mathbb{R}^m vectors $\{\vec{v}_1, \dots, \vec{v}_n\}$ spans \mathbb{R}^m if and only if $\text{RREF} [\vec{v}_1 \ \dots \ \vec{v}_n]$ has all pivot *rows*.
- A set of \mathbb{R}^m vectors $\{\vec{v}_1, \dots, \vec{v}_n\}$ fails to span \mathbb{R}^m if and only if $\text{RREF} [\vec{v}_1 \ \dots \ \vec{v}_n]$ has at least one non-pivot *row*.

Activity 2.4.8

- (a) Write a statement involving the solutions of a vector equation that's equivalent to each claim:

- (i) “The set of vectors $\left\{ \begin{bmatrix} 1 \\ -1 \\ 0 \\ -1 \end{bmatrix}, \begin{bmatrix} 5 \\ 5 \\ 3 \\ 1 \end{bmatrix}, \begin{bmatrix} 9 \\ 11 \\ 6 \\ 3 \end{bmatrix} \right\}$ is linearly *independent*.”
- (ii) “The set of vectors $\left\{ \begin{bmatrix} 1 \\ -1 \\ 0 \\ -1 \end{bmatrix}, \begin{bmatrix} 5 \\ 5 \\ 3 \\ 1 \end{bmatrix}, \begin{bmatrix} 9 \\ 11 \\ 6 \\ 3 \end{bmatrix} \right\}$ is linearly *dependent*.”

- (b) Explain how to determine which of these statements is true.

Activity 2.4.9 What is the largest number of \mathbb{R}^4 vectors that can form a linearly independent set?

A. 3

C. 5

B. 4

D. You can have infinitely many vectors and still be linearly independent.

Activity 2.4.10 Is it possible for the set of Euclidean vectors $\{\vec{v}_1, \vec{v}_2, \dots, \vec{v}_n, \vec{0}\}$ to be linearly independent?

A. Yes

B. No

2.4.3 Individual Practice

Remark 2.4.11 Recall that in [Activity 2.2.1](#) we used the words *vector*, *linear combination*, and *span* to make an analogy with recipes, ingredients, and meals. In this analogy, a *recipe* was defined to be a list of amounts of each ingredient to build a particular meal.

Activity 2.4.12 Consider the statement: The set of vectors $\{\vec{v}_1, \vec{v}_2, \vec{v}_3\}$ is linearly independent because the vector \vec{v}_3 is a linear combination of \vec{v}_1 and \vec{v}_2 . Construct an analogous statement involving ingredients, meals, and recipes, using the terms *linearly independent* and *linear combination*.

Activity 2.4.13 The following exercises are designed to help develop your geometric intuition around linear dependence.

(a) Draw sketches that depict the following:

- Three linearly independent vectors in \mathbb{R}^3 .
- Three linearly dependent vectors in \mathbb{R}^3 .

(b) If you have three linearly dependent vectors, is it necessarily the case that one of the vectors is a multiple of the other?

2.4.4 Videos



[Standalone](#)

Figure 15 Video: Linear independence

2.4.5 Exercises

Exercises available at <https://tbil.org/linear-algebra/preview/exercises/#/bank/EV4/>.

2.4.6 Mathematical Writing Explorations

Exploration 2.4.14 Prove the result of [Observation 2.4.7](#), by showing that, given a set $S = \{\vec{v}_1, \vec{v}_2, \dots, \vec{v}_n\}$ of vectors, S is linearly independent iff the equation $x_1\vec{v}_1 + x_2\vec{v}_2 + \dots + x_n\vec{v}_n = \vec{0}$ is only true when $x_1 = x_2 = \dots = x_n = 0$.

2.4.7 Sample Problem and Solution

Sample problem [Example B.1.8](#).

2.5 Identifying a Basis (EV5)

Learning Outcomes

- Explain why a set of Euclidean vectors is or is not a basis of \mathbb{R}^n .

2.5.1 Warm Up

Remark 2.5.1 Recall that in [Activity 2.2.1](#) we used the words *vector*, *linear combination*, and *span* to make an analogy with recipes, ingredients, and meals. In this analogy, a *recipe* was defined to be a list of amounts of each ingredient to build a particular meal.

Activity 2.5.2 Consider the following set of ingredients:

$$S = \{\text{tomato, olive oil, dough, cheese, pizza sauce, garlic}\}$$

- Does "pizza" live inside of $\text{span}(S)$?
- Identify which ingredients in S make the set linearly dependent.
- Can you think of a subset S' of S that is linearly independent and for which "pizza" is still in $\text{span } S'$?

2.5.2 Class Activities

Activity 2.5.3 Consider the set of vectors

$$S = \left\{ \begin{bmatrix} 3 \\ -2 \\ -1 \\ 0 \end{bmatrix}, \begin{bmatrix} 2 \\ 4 \\ 1 \\ 1 \end{bmatrix}, \begin{bmatrix} 0 \\ -16 \\ -5 \\ -3 \end{bmatrix}, \begin{bmatrix} 1 \\ 2 \\ 3 \\ 0 \end{bmatrix}, \begin{bmatrix} 3 \\ 3 \\ 0 \\ 1 \end{bmatrix} \right\}.$$

- (a) Express the vector $\begin{bmatrix} 5 \\ 2 \\ 0 \\ 1 \end{bmatrix}$ as a linear combination of the vectors in S , i.e. find scalars such that

$$\begin{bmatrix} 5 \\ 2 \\ 0 \\ 1 \end{bmatrix} = ? \begin{bmatrix} 3 \\ -2 \\ -1 \\ 0 \end{bmatrix} + ? \begin{bmatrix} 2 \\ 4 \\ 1 \\ 1 \end{bmatrix} + ? \begin{bmatrix} 0 \\ -16 \\ -5 \\ -3 \end{bmatrix} + ? \begin{bmatrix} 1 \\ 2 \\ 3 \\ 0 \end{bmatrix} + ? \begin{bmatrix} 3 \\ 3 \\ 0 \\ 1 \end{bmatrix}.$$

- (b) Find a *different* way to express the vector $\begin{bmatrix} 5 \\ 2 \\ 0 \\ 1 \end{bmatrix}$ as a linear combination of the vectors in S .

- (c) Consider another vector $\begin{bmatrix} 8 \\ 6 \\ 7 \\ 5 \end{bmatrix}$. Without computing the RREF of another matrix, how many ways can this vector be written as a linear combination of the vectors in S ?

- A. Zero.
- B. One.
- C. Infinitely-many.
- D. Computing a new matrix RREF is necessary.

Activity 2.5.4 Let's review some of the terminology we've been dealing with...

- (a) If every vector in a vector space can be constructed as one or more linear combinations of vectors in a set S , we can say...
- A. the set S spans the vector space.
 - B. the set S fails to span the vector space.
 - C. the set S is linearly independent.
 - D. the set S is linearly dependent.
- (b) If the zero vector $\vec{0}$ can be constructed as a *unique* linear combination of vectors in a set S (the combination multiplying every vector by the scalar value 0), we can say...
- A. the set S spans the vector space.
 - B. the set S fails to span the vector space.
 - C. the set S is linearly independent.
 - D. the set S is linearly dependent.

- (c) If every vector of a vector space can either be constructed as a *unique* linear combination of vectors in a set S , or not at all, we can say...
- the set S spans the vector space.
 - the set S fails to span the vector space.
 - the set S is linearly independent.
 - the set S is linearly dependent.

Definition 2.5.5 A **basis** of a vector space V is a set of vectors S contained in V for which

- Every vector in the vector space can be expressed as a linear combination of the vectors in S .
- For each vector \vec{v} in the vector space, there is only *one* way to write it as a linear combination of the vectors in S .

These two properties may be expressed more succinctly as the statement "Every vector in V can be expressed *uniquely* as a linear combination of the vectors in S ". \diamond

Observation 2.5.6 In terms of a vector equation, a set $S = \{\vec{v}_1, \dots, \vec{v}_n\}$ is a basis of a vector space if the vector equation

$$x_1\vec{v}_1 + \dots + x_n\vec{v}_n = \vec{w}$$

has a *unique* solution for *every* vector \vec{w} in the vector space.

Put another way, a basis may be thought of as a minimal set of "building blocks" that can be used to construct any other vector of the vector space.

Activity 2.5.7 Let S be a basis (Definition 2.5.5) for a vector space. Then...

- the set S must both span the vector space and be linearly independent.
- the set S must span the vector space but could be linearly dependent.
- the set S must be linearly independent but could fail to span the vector space.
- the set S could fail to span the vector space and could be linearly dependent.

Activity 2.5.8 The vectors

$$\hat{i} = (1, 0, 0) = \begin{bmatrix} 1 \\ 0 \\ 0 \end{bmatrix} \quad \hat{j} = (0, 1, 0) = \begin{bmatrix} 0 \\ 1 \\ 0 \end{bmatrix} \quad \hat{k} = (0, 0, 1) = \begin{bmatrix} 0 \\ 0 \\ 1 \end{bmatrix}$$

form a basis $\{\hat{i}, \hat{j}, \hat{k}\}$ used frequently in multivariable calculus.

Find the unique linear combination of these vectors

$$? \hat{i} + ? \hat{j} + ? \hat{k}$$

that equals the vector

$$(3, -2, 4) = \begin{bmatrix} 3 \\ -2 \\ 4 \end{bmatrix}$$

in xyz space.

Definition 2.5.9 The **standard basis** of \mathbb{R}^n is the set $\{\vec{e}_1, \dots, \vec{e}_n\}$ where

$$\vec{e}_1 = \begin{bmatrix} 1 \\ 0 \\ 0 \\ \vdots \\ 0 \\ 0 \end{bmatrix} \quad \vec{e}_2 = \begin{bmatrix} 0 \\ 1 \\ 0 \\ \vdots \\ 0 \\ 0 \end{bmatrix} \quad \dots \quad \vec{e}_n = \begin{bmatrix} 0 \\ 0 \\ 0 \\ \vdots \\ 0 \\ 1 \end{bmatrix}.$$

In particular, the standard basis for \mathbb{R}^3 is $\{\vec{e}_1, \vec{e}_2, \vec{e}_3\} = \{\hat{i}, \hat{j}, \hat{k}\}$. \diamond

Activity 2.5.10 Take the RREF of an appropriate matrix to determine if each of the following sets is a basis for \mathbb{R}^4 .

(a)

$$\left\{ \begin{bmatrix} 1 \\ 0 \\ 0 \\ 0 \end{bmatrix}, \begin{bmatrix} 0 \\ 1 \\ 0 \\ 0 \end{bmatrix}, \begin{bmatrix} 0 \\ 0 \\ 1 \\ 0 \end{bmatrix}, \begin{bmatrix} 0 \\ 0 \\ 0 \\ 1 \end{bmatrix} \right\}$$

- A. A basis, because it both spans \mathbb{R}^4 and is linearly independent.
- B. Not a basis, because while it spans \mathbb{R}^4 , it is linearly dependent.
- C. Not a basis, because while it is linearly independent, it fails to span \mathbb{R}^4 .
- D. Not a basis, because not only does it fail to span \mathbb{R}^4 , it's also linearly dependent.

(b)

$$\left\{ \begin{bmatrix} 2 \\ 3 \\ 0 \\ -1 \end{bmatrix}, \begin{bmatrix} 2 \\ 0 \\ 0 \\ 3 \end{bmatrix}, \begin{bmatrix} 4 \\ 3 \\ 0 \\ 2 \end{bmatrix}, \begin{bmatrix} -3 \\ 0 \\ 1 \\ 3 \end{bmatrix} \right\}$$

- A. A basis, because it both spans \mathbb{R}^4 and is linearly independent.
- B. Not a basis, because while it spans \mathbb{R}^4 , it is linearly dependent.
- C. Not a basis, because while it is linearly independent, it fails to span \mathbb{R}^4 .
- D. Not a basis, because not only does it fail to span \mathbb{R}^4 , it's also linearly dependent.

(c)

$$\left\{ \begin{bmatrix} 2 \\ 3 \\ 0 \\ -1 \end{bmatrix}, \begin{bmatrix} 2 \\ 0 \\ 0 \\ 3 \end{bmatrix}, \begin{bmatrix} 3 \\ 13 \\ 7 \\ 16 \end{bmatrix}, \begin{bmatrix} -1 \\ 10 \\ 7 \\ 14 \end{bmatrix}, \begin{bmatrix} 4 \\ 3 \\ 0 \\ 2 \end{bmatrix} \right\}$$

- A. A basis, because it both spans \mathbb{R}^4 and is linearly independent.
 B. Not a basis, because while it spans \mathbb{R}^4 , it is linearly dependent.
 C. Not a basis, because while it is linearly independent, it fails to span \mathbb{R}^4 .
 D. Not a basis, because not only does it fail to span \mathbb{R}^4 , it's also linearly dependent.

(d)

$$\left\{ \begin{bmatrix} 2 \\ 3 \\ 0 \\ -1 \end{bmatrix}, \begin{bmatrix} 4 \\ 3 \\ 0 \\ 2 \end{bmatrix}, \begin{bmatrix} -3 \\ 0 \\ 1 \\ 3 \end{bmatrix}, \begin{bmatrix} 3 \\ 6 \\ 1 \\ 5 \end{bmatrix} \right\}$$

- A. A basis, because it both spans \mathbb{R}^4 and is linearly independent.
 B. Not a basis, because while it spans \mathbb{R}^4 , it is linearly dependent.
 C. Not a basis, because while it is linearly independent, it fails to span \mathbb{R}^4 .
 D. Not a basis, because not only does it fail to span \mathbb{R}^4 , it's also linearly dependent.

(e)

$$\left\{ \begin{bmatrix} 5 \\ 3 \\ 0 \\ -1 \end{bmatrix}, \begin{bmatrix} -2 \\ 1 \\ 0 \\ 3 \end{bmatrix}, \begin{bmatrix} 4 \\ 5 \\ 1 \\ 3 \end{bmatrix} \right\}$$

- A. A basis, because it both spans \mathbb{R}^4 and is linearly independent.
 B. Not a basis, because while it spans \mathbb{R}^4 , it is linearly dependent.
 C. Not a basis, because while it is linearly independent, it fails to span \mathbb{R}^4 .
 D. Not a basis, because not only does it fail to span \mathbb{R}^4 , it's also linearly dependent.

Activity 2.5.11 If $\{\vec{v}_1, \vec{v}_2, \vec{v}_3, \vec{v}_4\}$ is a basis for \mathbb{R}^4 , that means $\text{RREF}[\vec{v}_1 \ \vec{v}_2 \ \vec{v}_3 \ \vec{v}_4]$ has a pivot in every row (because it spans), and has a pivot in every column (because it's linearly independent).

What is $\text{RREF}[\vec{v}_1 \ \vec{v}_2 \ \vec{v}_3 \ \vec{v}_4]$?

$$\text{RREF}[\vec{v}_1 \ \vec{v}_2 \ \vec{v}_3 \ \vec{v}_4] = \begin{bmatrix} ? & ? & ? & ? \\ ? & ? & ? & ? \\ ? & ? & ? & ? \\ ? & ? & ? & ? \end{bmatrix}$$

Fact 2.5.12 *The set $\{\vec{v}_1, \dots, \vec{v}_m\}$ is a basis for \mathbb{R}^n if and only if $m = n$ and $\text{RREF}[\vec{v}_1 \ \dots \ \vec{v}_n] =$*

$$\begin{bmatrix} 1 & 0 & \dots & 0 \\ 0 & 1 & \dots & 0 \\ \vdots & \vdots & \ddots & \vdots \\ 0 & 0 & \dots & 1 \end{bmatrix}.$$

*That is, a basis for \mathbb{R}^n must have exactly n vectors and its square matrix must row-reduce to the so-called **identity matrix** containing all zeros except for a downward diagonal of ones. (We will learn where the identity matrix gets its name in a later module.)*

2.5.3 Individual Practice

Activity 2.5.13 Let S denote a set of vectors in \mathbb{R}^n . Without referring to your Activity Book, write down:

- (a) The definition of what it means for S to be linearly independent.
- (b) The definition of what it means for S to span \mathbb{R}^n .
- (c) The definition of what it means for S to be a basis for \mathbb{R}^n .

Activity 2.5.14 You are going on a trip and need to pack. Let S denote the set of items that you are packing in your suitcase.

- (a) Give an example of such a set of items S that you would say "spans" everything you need, but is linearly dependent.
- (b) Give an example of such a set of items S that is linearly independent, but does not "span" everything you need.
- (c) Give an example of such a set S that you might reasonably consider to be a "basis" for what you need?

2.5.4 Videos

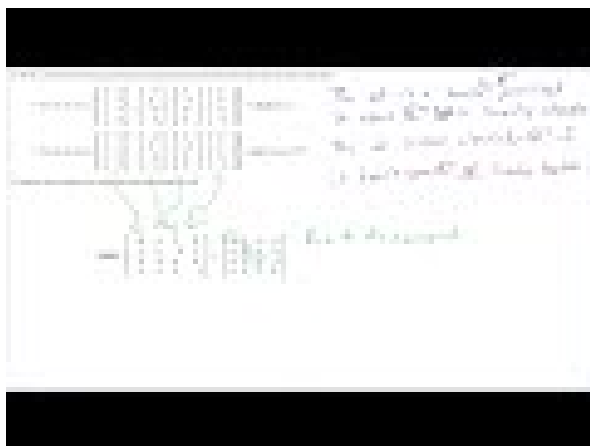

Standalone

Figure 16 Video: Verifying that a set of vectors is a basis of a vector space

2.5.5 Exercises

Exercises available at <https://tbil.org/linear-algebra/preview/exercises/#/bank/EV5/>.

2.5.6 Mathematical Writing Explorations

Exploration 2.5.15

- What is a basis for $M_{2,2}$?
- What about $M_{3,3}$?
- Could we write each of these in a way that looks like the standard basis vectors in \mathbb{R}^m for some m ? Make a conjecture about the relationship between these spaces of matrices and standard Euclidean space.

Exploration 2.5.16 Recall our earlier definition of symmetric matrices. Find a basis for each of the following:

- The space of 2×2 symmetric matrices.
- The space of 3×3 symmetric matrices.
- The space of $n \times n$ symmetric matrices.

Exploration 2.5.17 Must a basis for the space P_2 , the space of all quadratic polynomials, contain a polynomial of each degree less than or equal to 2? Generalize your result to polynomials of arbitrary degree.

2.5.7 Sample Problem and Solution

Sample problem [Example B.1.9](#).

2.6 Subspace Basis and Dimension (EV6)

Learning Outcomes

- Compute a basis for the subspace spanned by a given set of Euclidean vectors, and determine the dimension of the subspace.

2.6.1 Warm Up

Activity 2.6.1 Consider the set S of vectors in \mathbb{R}^4 given by

$$S = \left\{ \begin{bmatrix} 2 \\ 3 \\ 0 \\ 1 \end{bmatrix}, \begin{bmatrix} 2 \\ 0 \\ 1 \\ -1 \end{bmatrix} \right\}$$

- Is the set S linearly independent or linearly dependent?
- How would you describe the subspace $\text{span } S$ geometrically?
- What do the spaces $\text{span } S$ and \mathbb{R}^2 have in common? In what ways do they differ?

2.6.2 Class Activities

Observation 2.6.2 Recall from section [Section 2.3](#) that a **subspace** of a vector space is the result of spanning a set of vectors from that vector space.

Recall also that a linearly dependent set contains “redundant” vectors. For example, only two of the three vectors in [Figure 14](#) are needed to span the planar subspace.

Activity 2.6.3 Consider the subspace of \mathbb{R}^4 given by $W =$

$$\text{span} \left\{ \begin{bmatrix} 2 \\ 3 \\ 0 \\ 1 \end{bmatrix}, \begin{bmatrix} 2 \\ 0 \\ 1 \\ -1 \end{bmatrix}, \begin{bmatrix} 2 \\ -3 \\ 2 \\ -3 \end{bmatrix}, \begin{bmatrix} 1 \\ 5 \\ -1 \\ 0 \end{bmatrix} \right\}.$$

- Mark the column of RREF $\begin{bmatrix} 2 & 2 & 2 & 1 \\ 3 & 0 & -3 & 5 \\ 0 & 1 & 2 & -1 \\ 1 & -1 & -3 & 0 \end{bmatrix}$ that shows that W 's spanning set is linearly dependent.

- What would be the result of removing the vector that gave us this column?

- The set still spans W , and remains linearly dependent.
- The set still spans W , but is now also linearly independent.
- The set no longer spans W , and remains linearly dependent.
- The set no longer spans W , but is now linearly independent.

$\text{rref}([2, 2, 2, 1; 3, 0, -3, 5; 0, 1, 2, -1; 1, -1, -3, 0])$

Definition 2.6.4 Let W be a subspace of a vector space. A **basis** for W is a linearly independent set of vectors that spans W (but not necessarily the entire vector space). \diamond

Observation 2.6.5 So given a set $S = \{\vec{v}_1, \dots, \vec{v}_m\}$, to compute a basis for the subspace $\text{span } S$, simply remove the vectors corresponding to the non-pivot columns of $\text{RREF}[\vec{v}_1 \dots \vec{v}_m]$. For example, since

$$\text{RREF} \begin{bmatrix} 1 & 2 & 0 & 1 \\ 2 & 4 & -2 & 2 \\ 3 & 6 & -2 & 1 \end{bmatrix} = \begin{bmatrix} \boxed{1} & 2 & 0 & 1 \\ 0 & 0 & \boxed{1} & 1 \\ 0 & 0 & 0 & 0 \end{bmatrix}$$

the subspace $W = \text{span} \left\{ \begin{bmatrix} 1 \\ 2 \\ 3 \end{bmatrix}, \begin{bmatrix} 2 \\ 4 \\ 6 \end{bmatrix}, \begin{bmatrix} 0 \\ -2 \\ -2 \end{bmatrix}, \begin{bmatrix} 1 \\ 2 \\ 1 \end{bmatrix} \right\}$ has $\left\{ \begin{bmatrix} 1 \\ 2 \\ 3 \end{bmatrix}, \begin{bmatrix} 0 \\ -2 \\ -2 \end{bmatrix} \right\}$ as a basis.

Activity 2.6.6

(a) Find a basis for $\text{span } S$ where

$$S = \left\{ \begin{bmatrix} 2 \\ 3 \\ 0 \\ 1 \end{bmatrix}, \begin{bmatrix} 2 \\ 0 \\ 1 \\ -1 \end{bmatrix}, \begin{bmatrix} 2 \\ -3 \\ 2 \\ -3 \end{bmatrix}, \begin{bmatrix} 1 \\ 5 \\ -1 \\ 0 \end{bmatrix} \right\}.$$

(b) Find a basis for $\text{span } T$ where

$$T = \left\{ \begin{bmatrix} 2 \\ 0 \\ 1 \\ -1 \end{bmatrix}, \begin{bmatrix} 2 \\ -3 \\ 2 \\ -3 \end{bmatrix}, \begin{bmatrix} 1 \\ 5 \\ -1 \\ 0 \end{bmatrix}, \begin{bmatrix} 2 \\ 3 \\ 0 \\ 1 \end{bmatrix} \right\}.$$

Observation 2.6.7 Even though we found different bases for them, $\text{span } S$ and $\text{span } T$ are exactly the same subspace of \mathbb{R}^4 , since

$$S = \left\{ \begin{bmatrix} 2 \\ 3 \\ 0 \\ 1 \end{bmatrix}, \begin{bmatrix} 2 \\ 0 \\ 1 \\ -1 \end{bmatrix}, \begin{bmatrix} 2 \\ -3 \\ 2 \\ -3 \end{bmatrix}, \begin{bmatrix} 1 \\ 5 \\ -1 \\ 0 \end{bmatrix} \right\} = \left\{ \begin{bmatrix} 2 \\ 0 \\ 1 \\ -1 \end{bmatrix}, \begin{bmatrix} 2 \\ -3 \\ 2 \\ -3 \end{bmatrix}, \begin{bmatrix} 1 \\ 5 \\ -1 \\ 0 \end{bmatrix}, \begin{bmatrix} 2 \\ 3 \\ 0 \\ 1 \end{bmatrix} \right\} = T.$$

Thus the basis for a subspace is not unique in general.

Fact 2.6.8 Any non-trivial real vector space has infinitely-many different bases, but all the bases for a given vector space are exactly the same size.

For example,

$$\{\vec{e}_1, \vec{e}_2, \vec{e}_3\} \text{ and } \left\{ \begin{bmatrix} 1 \\ 0 \\ 0 \end{bmatrix}, \begin{bmatrix} 0 \\ 1 \\ 0 \end{bmatrix}, \begin{bmatrix} 1 \\ 1 \\ 1 \end{bmatrix} \right\} \text{ and } \left\{ \begin{bmatrix} 1 \\ 0 \\ -3 \end{bmatrix}, \begin{bmatrix} 2 \\ -2 \\ 1 \end{bmatrix}, \begin{bmatrix} 3 \\ -2 \\ 5 \end{bmatrix} \right\}$$

are all valid bases for \mathbb{R}^3 , and they all contain three vectors.

Definition 2.6.9 The **dimension** of a vector space or subspace is equal to the size of any basis for the vector space.

As you'd expect, \mathbb{R}^n has dimension n . For example, \mathbb{R}^3 has dimension 3 because any basis for \mathbb{R}^3 such as

$$\{\vec{e}_1, \vec{e}_2, \vec{e}_3\} \text{ and } \left\{ \begin{bmatrix} 1 \\ 0 \\ 0 \end{bmatrix}, \begin{bmatrix} 0 \\ 1 \\ 0 \end{bmatrix}, \begin{bmatrix} 1 \\ 1 \\ 1 \end{bmatrix} \right\} \text{ and } \left\{ \begin{bmatrix} 1 \\ 0 \\ -3 \end{bmatrix}, \begin{bmatrix} 2 \\ -2 \\ 1 \end{bmatrix}, \begin{bmatrix} 3 \\ -2 \\ 5 \end{bmatrix} \right\}$$

contains exactly three vectors. ◇

Activity 2.6.10 Consider the following subspace W of \mathbb{R}^4 :

$$W = \text{span} \left\{ \begin{bmatrix} 1 \\ 0 \\ 0 \\ -1 \end{bmatrix}, \begin{bmatrix} -2 \\ 0 \\ 0 \\ 2 \end{bmatrix}, \begin{bmatrix} -3 \\ 1 \\ -5 \\ 5 \end{bmatrix}, \begin{bmatrix} 12 \\ -3 \\ 15 \\ -18 \end{bmatrix} \right\}.$$

- (a) Explain and demonstrate how to find a basis of W .
- (b) Explain and demonstrate how to find the dimension of W .

Activity 2.6.11 The dimension of a subspace may be found by doing what with an appropriate RREF matrix?

- A. Count the rows.
- B. Count the non-pivot columns.
- C. Count the pivots.
- D. Add the number of pivot rows and pivot columns.

2.6.3 Individual Practice

Activity 2.6.12 In [Observation 2.6.5](#), we found a basis for the subspace

$$W = \text{span} \left\{ \begin{bmatrix} 1 \\ 2 \\ 3 \end{bmatrix}, \begin{bmatrix} 2 \\ 4 \\ 6 \end{bmatrix}, \begin{bmatrix} 0 \\ -2 \\ -2 \end{bmatrix}, \begin{bmatrix} 1 \\ 2 \\ 1 \end{bmatrix} \right\}.$$

To do so, we use the results of the calculation:

$$\text{RREF} \begin{bmatrix} 1 & 2 & 0 & 1 \\ 2 & 4 & -2 & 2 \\ 3 & 6 & -2 & 1 \end{bmatrix} = \begin{bmatrix} \boxed{1} & 2 & 0 & 1 \\ 0 & 0 & \boxed{1} & 1 \\ 0 & 0 & 0 & 0 \end{bmatrix}$$

to conclude that the set $\left\{ \begin{bmatrix} 1 \\ 2 \\ 3 \end{bmatrix}, \begin{bmatrix} 0 \\ -2 \\ -2 \end{bmatrix} \right\}$, the set of vectors *corresponding* to the pivot columns of the RREF, is a basis for W .

(a) Explain why neither of the vectors $\begin{bmatrix} 1 \\ 0 \\ 0 \end{bmatrix}$, $\begin{bmatrix} 0 \\ 1 \\ 0 \end{bmatrix}$ are elements of W .

(b) Explain why this shows that, in general, when we calculate a basis for $W = \text{span}\{\vec{v}_1, \dots, \vec{v}_n\}$, the pivot columns of $\text{RREF}[\vec{v}_1 \dots \vec{v}_n]$ themselves do not form a basis for W .

2.6.4 Videos



Standalone

Figure 17 Video: Finding a basis of a subspace and computing the dimension of a subspace

2.6.5 Exercises

Exercises available at <https://tbil.org/linear-algebra/preview/exercises/#/bank/EV6/>.

2.6.6 Mathematical Writing Explorations

Exploration 2.6.13 Prove each of the following statements is true.

- If $\{\vec{b}_1, \vec{b}_2, \dots, \vec{b}_m\}$ and $\{\vec{c}_1, \vec{c}_2, \dots, \vec{c}_n\}$ are each a basis for a vector space V , then $m = n$.
- If $\{\vec{v}_1, \vec{v}_2, \dots, \vec{v}_n\}$ is linearly independent, then so is $\{\vec{v}_1, \vec{v}_1 + \vec{v}_2, \dots, \vec{v}_1 + \vec{v}_2 + \dots + \vec{v}_n\}$.
- Let V be a vector space of dimension n , and $\vec{v} \in V$. Then there exists a basis for V

and the augmented matrix:

$$\left[\begin{array}{cccc|c} a_{11} & a_{12} & \cdots & a_{1n} & 0 \\ a_{21} & a_{22} & \cdots & a_{2n} & 0 \\ \vdots & \vdots & \ddots & \vdots & \vdots \\ a_{m1} & a_{m2} & \cdots & a_{mn} & 0 \end{array} \right].$$

Activity 2.7.2 In [Section 2.3](#), we observed that if

$$x_1\vec{v}_1 + \cdots + x_n\vec{v}_n = \vec{0}$$

is a homogenous vector equation, then:

- The zero vector $\vec{0}$ is a solution;
- The sum of any two solutions is again a solution;
- Multiplying a solution by a scalar produces another solution.

Based on this recollection, which of the following best describes the solution set to the homogenous equation?

- A. A basis for \mathbb{R}^n .
- B. A subspace of \mathbb{R}^n .
- C. All of \mathbb{R}^n .
- D. The empty set.

2.7.2 Class Activities

Activity 2.7.3 Consider the homogeneous system of equations

$$\begin{aligned} x_1 + 2x_2 + x_4 &= 0 \\ 2x_1 + 4x_2 - x_3 - 2x_4 &= 0 \\ 3x_1 + 6x_2 - x_3 - x_4 &= 0 \end{aligned}$$

- (a) Find its solution set (a subspace of \mathbb{R}^4).
- (b) Rewrite this solution space in the form

$$\left\{ a \begin{bmatrix} ? \\ ? \\ ? \\ ? \end{bmatrix} + b \begin{bmatrix} ? \\ ? \\ ? \\ ? \end{bmatrix} \mid a, b \in \mathbb{R} \right\}.$$

(c) Rewrite this solution space in the form

$$\text{span} \left\{ \begin{bmatrix} ? \\ ? \\ ? \\ ? \end{bmatrix}, \begin{bmatrix} ? \\ ? \\ ? \\ ? \end{bmatrix} \right\}.$$

(d) Which of these choices best describes the set of two vectors $\left\{ \begin{bmatrix} ? \\ ? \\ ? \\ ? \end{bmatrix}, \begin{bmatrix} ? \\ ? \\ ? \\ ? \end{bmatrix} \right\}$ used in this span?

- A. The set is linearly dependent.
- B. The set is linearly independent.
- C. The set spans all of \mathbb{R}^4 .
- D. The set fails to span the solution space.

Fact 2.7.4 *The coefficients of the free variables in the solution space of a linear system always yield linearly independent vectors that span the solution space.*

Thus if

$$\left\{ a \begin{bmatrix} -2 \\ 1 \\ 0 \\ 0 \end{bmatrix} + b \begin{bmatrix} -1 \\ 0 \\ -4 \\ 1 \end{bmatrix} \mid a, b \in \mathbb{R} \right\} = \text{span} \left\{ \begin{bmatrix} -2 \\ 1 \\ 0 \\ 0 \end{bmatrix}, \begin{bmatrix} -1 \\ 0 \\ -4 \\ 1 \end{bmatrix} \right\}$$

is the solution space for a homogeneous system, then

$$\left\{ \begin{bmatrix} -2 \\ 1 \\ 0 \\ 0 \end{bmatrix}, \begin{bmatrix} -1 \\ 0 \\ -4 \\ 1 \end{bmatrix} \right\}$$

is a basis for the solution space.

Activity 2.7.5 Consider the homogeneous system of equations

$$\begin{aligned} 2x_1 + 4x_2 + 2x_3 - 4x_4 &= 0 \\ -2x_1 - 4x_2 + x_3 + x_4 &= 0 \\ 3x_1 + 6x_2 - x_3 - 4x_4 &= 0 \end{aligned}$$

Find a basis for its solution space.

Activity 2.7.6 Consider the homogeneous vector equation

$$x_1 \begin{bmatrix} 2 \\ -2 \\ 3 \end{bmatrix} + x_2 \begin{bmatrix} 4 \\ -4 \\ 6 \end{bmatrix} + x_3 \begin{bmatrix} 2 \\ 1 \\ -1 \end{bmatrix} + x_4 \begin{bmatrix} -4 \\ 1 \\ -4 \end{bmatrix} = \begin{bmatrix} 0 \\ 0 \\ 0 \end{bmatrix}$$

Find a basis for its solution space.

Activity 2.7.7 Consider the homogeneous system of equations

$$\begin{aligned} x_1 - 3x_2 + 2x_3 &= 0 \\ 2x_1 + 6x_2 + 4x_3 &= 0 \\ x_1 + 6x_2 - 4x_3 &= 0 \end{aligned}$$

(a) Find its solution space.

(b) Which of these is the best choice of basis for this solution space?

A $\{\}$

B $\{\vec{0}\}$

C The basis does not exist

Activity 2.7.8 To create a computer-animated film, an animator first models a scene as a subset of \mathbb{R}^3 . Then to transform this three-dimensional visual data for display on a two-dimensional movie screen or television set, the computer could apply a linear transformation that maps visual information at the point $(x, y, z) \in \mathbb{R}^3$ onto the pixel located at $(x + y, y - z) \in \mathbb{R}^2$.

(a) What homogeneous linear system describes the positions (x, y, z) within the original scene that would be aligned with the pixel $(0, 0)$ on the screen?

(b) Solve this system to describe these locations.

2.7.3 Individual Practice

Activity 2.7.9 Let $S = \left\{ \begin{bmatrix} -2 \\ 1 \\ 0 \\ 0 \end{bmatrix}, \begin{bmatrix} -1 \\ 0 \\ -4 \\ 1 \end{bmatrix}, \begin{bmatrix} 1 \\ 0 \\ -2 \\ 3 \end{bmatrix} \right\}$ and $A = \begin{bmatrix} -2 & -1 & 1 \\ 1 & 0 & 0 \\ 0 & -4 & -2 \\ 0 & 1 & 3 \end{bmatrix}$; note

that

$$\text{RREF}(A) = \begin{bmatrix} 1 & 0 & 0 \\ 0 & 1 & 0 \\ 0 & 0 & 1 \\ 0 & 0 & 0 \end{bmatrix}.$$

The following statements are all *invalid* for at least one reason. Determine what makes them invalid and, suggest alternative *valid* statements that the author may have meant instead.

(a) The matrix A is linearly independent because $\text{RREF}(A)$ has a pivot in each column.

- (b) The matrix A does not span \mathbb{R}^4 because $\text{RREF}(A)$ has a row of zeroes.
- (c) The set of vectors S spans.
- (d) The set of vectors S is a basis.

2.7.4 Videos



Standalone

Figure 18 Video: Polynomial and matrix calculations

2.7.5 Exercises

Exercises available at <https://tbil.org/linear-algebra/preview/exercises/#/bank/EV7/>.

2.7.6 Mathematical Writing Explorations

Exploration 2.7.10 An $n \times n$ matrix M is **non-singular** if the associated homogeneous system with coefficient matrix M is consistent with one solution. Assume the matrices in the writing explorations in this section are all non-singular.

- Prove that the reduced row echelon form of M is the identity matrix.

- Prove that, for any column vector $\vec{b} = \begin{bmatrix} b_1 \\ b_2 \\ \vdots \\ b_n \end{bmatrix}$, the system of equations given by

$\left[M \mid \vec{b} \right]$ has a unique solution.

- Prove that the columns of M form a basis for \mathbb{R}^n .
- Prove that the rank of M is n .

2.7.7 Sample Problem and Solution

Sample problem [Example B.1.11](#).

Chapter 3

Algebraic Properties of Linear Maps (AT)

Learning Outcomes

How can we understand linear maps algebraically?
By the end of this chapter, you should be able to...

1. Determine if a map between Euclidean vector spaces is linear or not.
2. Translate back and forth between a linear transformation of Euclidean spaces and its standard matrix, and perform related computations.
3. Compute a basis for the kernel and a basis for the image of a linear map, and verify that the rank-nullity theorem holds for a given linear map.
4. Determine if a given linear map is injective and/or surjective.
5. Explain why a given set with defined addition and scalar multiplication does satisfy a given vector space property, but nonetheless isn't a vector space.
6. Answer questions about vector spaces of polynomials or matrices.

Readiness Assurance. Before beginning this chapter, you should be able to...

1. State the definition of a spanning set, and determine if a set of Euclidean vectors spans \mathbb{R}^n .
 - Review: [Section 2.2](#)
2. State the definition of linear independence, and determine if a set of Euclidean vectors is linearly dependent or independent.
 - Review: [Section 2.4](#)
3. State the definition of a basis, and determine if a set of Euclidean vectors is a basis.

- Review: [Section 2.5](#), [Section 2.6](#)
4. Find a basis of the solution space to a homogeneous system of linear equations.
- Review: [Section 2.7](#)

3.1 Linear Transformations (AT1)

Learning Outcomes

- Determine if a map between Euclidean vector spaces is linear or not.

3.1.1 Warm Up

Activity 3.1.1

- (a) What is our definition for a set S of vectors to be linearly independent?
- (b) What specific calculation would you perform to test if a set S of Euclidean vectors is linearly independent?

Activity 3.1.2

- (a) What is our definition for a set S of vectors in \mathbb{R}^n to span \mathbb{R}^n ?
- (b) What specific calculation would you perform to test if a set S of Euclidean vectors spans all of \mathbb{R}^n ?

3.1.2 Class Activities

Definition 3.1.3 A **linear transformation** (also called a **linear map**) is a map between vector spaces that preserves the vector space operations. More precisely, if V and W are vector spaces, a map $T : V \rightarrow W$ is called a linear transformation if

1. $T(\vec{v} + \vec{w}) = T(\vec{v}) + T(\vec{w})$ for any $\vec{v}, \vec{w} \in V$, and
2. $T(c\vec{v}) = cT(\vec{v})$ for any $c \in \mathbb{R}$, and $\vec{v} \in V$.

In other words, a map is linear when vector space operations can be applied before or after the transformation without affecting the result. \diamond

Definition 3.1.4 Given a linear transformation $T : V \rightarrow W$, V is called the **domain** of T and W is called the **co-domain** of T .

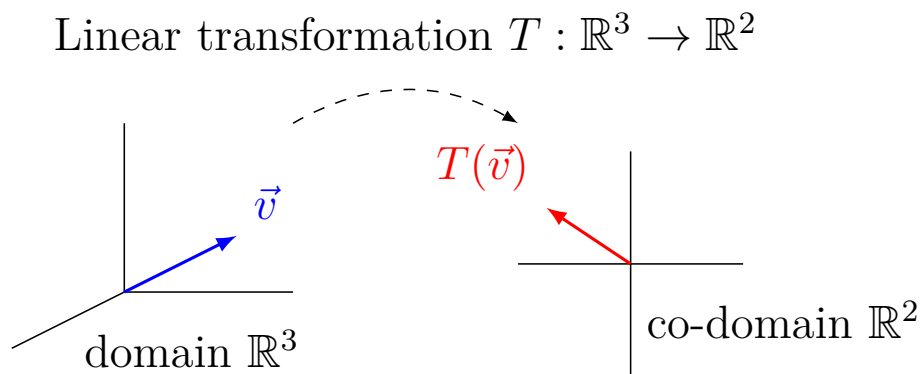

Figure 19 A linear transformation with a domain of \mathbb{R}^3 and a co-domain of \mathbb{R}^2

◇

Observation 3.1.5 One example of a linear transformation $\mathbb{R}^3 \rightarrow \mathbb{R}^2$ is the projection of three-dimensional data onto a two-dimensional screen, as is necessary for computer animation in film or video games.

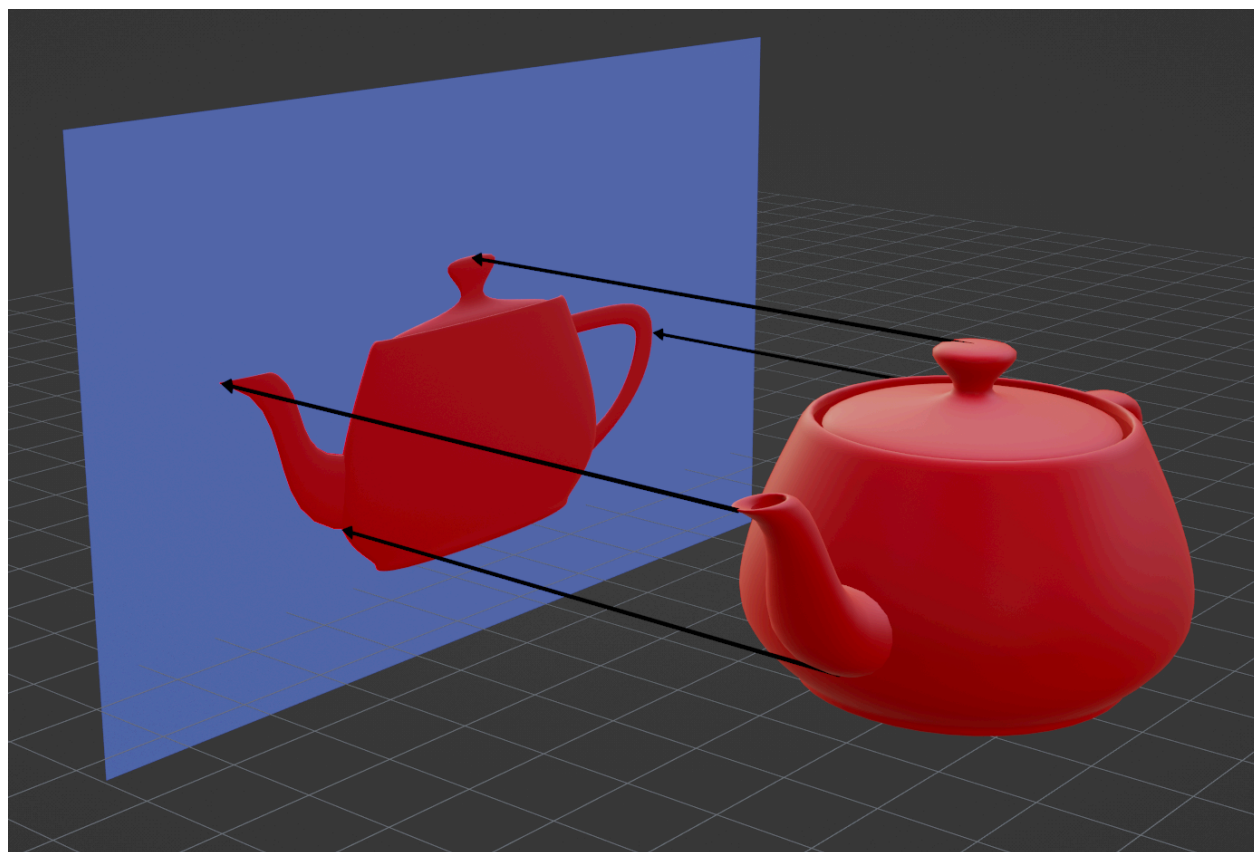

Figure 20 A projection of a 3D teapot onto a 2D screen

Activity 3.1.6 Let $T : \mathbb{R}^3 \rightarrow \mathbb{R}^2$ be given by

$$T \left(\begin{bmatrix} x \\ y \\ z \end{bmatrix} \right) = \begin{bmatrix} x - z \\ 3y \end{bmatrix}.$$

(a) Compute the result of adding vectors before a T transformation:

$$T \left(\begin{bmatrix} x \\ y \\ z \end{bmatrix} + \begin{bmatrix} u \\ v \\ w \end{bmatrix} \right) = T \left(\begin{bmatrix} x + u \\ y + v \\ z + w \end{bmatrix} \right)$$

A. $\begin{bmatrix} x - u + z - w \\ 3y - 3v \end{bmatrix}$

C. $\begin{bmatrix} x + u \\ 3y + 3v \\ z + w \end{bmatrix}$

B. $\begin{bmatrix} x + u - z - w \\ 3y + 3v \end{bmatrix}$

D. $\begin{bmatrix} x - u \\ 3y - 3v \\ z - w \end{bmatrix}$

(b) Compute the result of adding vectors after a T transformation:

$$T \left(\begin{bmatrix} x \\ y \\ z \end{bmatrix} \right) + T \left(\begin{bmatrix} u \\ v \\ w \end{bmatrix} \right) = \begin{bmatrix} x - z \\ 3y \end{bmatrix} + \begin{bmatrix} u - w \\ 3v \end{bmatrix}$$

A. $\begin{bmatrix} x - u + z - w \\ 3y - 3v \end{bmatrix}$

C. $\begin{bmatrix} x + u \\ 3y + 3v \\ z + w \end{bmatrix}$

B. $\begin{bmatrix} x + u - z - w \\ 3y + 3v \end{bmatrix}$

D. $\begin{bmatrix} x - u \\ 3y - 3v \\ z - w \end{bmatrix}$

(c) Is T a linear transformation?

A. Yes.

B. No.

C. More work is necessary to know.

(d) Compute the result of scalar multiplication before a T transformation:

$$T \left(c \begin{bmatrix} x \\ y \\ z \end{bmatrix} \right) = T \left(\begin{bmatrix} cx \\ cy \\ cz \end{bmatrix} \right)$$

A. $\begin{bmatrix} cx - cz \\ 3cy \end{bmatrix}$

C. $\begin{bmatrix} x + c \\ 3y + c \\ z + c \end{bmatrix}$

B. $\begin{bmatrix} cx + cz \\ -3cy \end{bmatrix}$

D. $\begin{bmatrix} x - c \\ 3y - c \\ z - c \end{bmatrix}$

(e) Compute the result of scalar multiplication after a T transformation:

$$cT\left(\begin{bmatrix} x \\ y \\ z \end{bmatrix}\right) = c\begin{bmatrix} x - z \\ 3y \end{bmatrix}$$

A. $\begin{bmatrix} cx - cz \\ 3cy \end{bmatrix}$

C. $\begin{bmatrix} x + c \\ 3y + c \\ z + c \end{bmatrix}$

B. $\begin{bmatrix} cx + cz \\ -3cy \end{bmatrix}$

D. $\begin{bmatrix} x - c \\ 3y - c \\ z - c \end{bmatrix}$

(f) Is T a linear transformation?

A. Yes.

B. No.

C. More work is necessary to know.

Activity 3.1.7 Let $S : \mathbb{R}^2 \rightarrow \mathbb{R}^4$ be given by

$$S\left(\begin{bmatrix} x \\ y \end{bmatrix}\right) = \begin{bmatrix} x + y \\ x^2 \\ y + 3 \\ y - 2^x \end{bmatrix}$$

(a) Compute

$$S\left(\begin{bmatrix} 0 \\ 1 \end{bmatrix} + \begin{bmatrix} 2 \\ 3 \end{bmatrix}\right) = S\left(\begin{bmatrix} 2 \\ 4 \end{bmatrix}\right)$$

A. $\begin{bmatrix} 6 \\ 4 \\ 7 \\ 0 \end{bmatrix}$

B. $\begin{bmatrix} -3 \\ 0 \\ 1 \\ 5 \end{bmatrix}$

C. $\begin{bmatrix} -3 \\ -1 \\ 7 \\ 5 \end{bmatrix}$

D. $\begin{bmatrix} 6 \\ 4 \\ 10 \\ -1 \end{bmatrix}$

(b) Compute

$$S\left(\begin{bmatrix} 0 \\ 1 \end{bmatrix}\right) + S\left(\begin{bmatrix} 2 \\ 3 \end{bmatrix}\right) = \begin{bmatrix} 0 + 1 \\ 0^2 \\ 1 + 3 \\ 1 - 2^0 \end{bmatrix} + \begin{bmatrix} 2 + 3 \\ 2^2 \\ 3 + 3 \\ 3 - 2^2 \end{bmatrix}$$

A. $\begin{bmatrix} 6 \\ 4 \\ 7 \\ 0 \end{bmatrix}$

B. $\begin{bmatrix} -3 \\ 0 \\ 1 \\ 5 \end{bmatrix}$

C. $\begin{bmatrix} -3 \\ -1 \\ 7 \\ 5 \end{bmatrix}$

D. $\begin{bmatrix} 6 \\ 4 \\ 10 \\ -1 \end{bmatrix}$

(c) Is T a linear transformation?

- A. Yes.
- B. No.
- C. More work is necessary to know.

Activity 3.1.8 Fill in the ?s, assuming $T : \mathbb{R}^3 \rightarrow \mathbb{R}^3$ is linear:

$$T \left(\begin{bmatrix} 0 \\ 0 \\ 0 \end{bmatrix} \right) = T \left(? \begin{bmatrix} 1 \\ 1 \\ 1 \end{bmatrix} \right) = ? T \left(\begin{bmatrix} 1 \\ 1 \\ 1 \end{bmatrix} \right) = \begin{bmatrix} ? \\ ? \\ ? \end{bmatrix}$$

Remark 3.1.9 In summary, *any one* of the following is enough to prove that $T : V \rightarrow W$ is *not* a linear transformation:

- Find specific values for $\vec{v}, \vec{w} \in V$ such that $T(\vec{v} + \vec{w}) \neq T(\vec{v}) + T(\vec{w})$.
- Find specific values for $\vec{v} \in V$ and $c \in \mathbb{R}$ such that $T(c\vec{v}) \neq cT(\vec{v})$.
- Show $T(\vec{0}) \neq \vec{0}$.

If you cannot do any of these, then T can be proven to be a linear transformation by doing *both* of the following:

1. For all $\vec{v}, \vec{w} \in V$ (not just specific values), $T(\vec{v} + \vec{w}) = T(\vec{v}) + T(\vec{w})$.
2. For all $\vec{v} \in V$ and $c \in \mathbb{R}$ (not just specific values), $T(c\vec{v}) = cT(\vec{v})$.

(Note the similarities between this process and showing that a subset of a vector space is or is not a subspace: [Remark 2.3.11](#).)

Activity 3.1.10

- (a) Consider the following maps of Euclidean vectors $P : \mathbb{R}^3 \rightarrow \mathbb{R}^3$ and $Q : \mathbb{R}^3 \rightarrow \mathbb{R}^3$ defined by

$$P \left(\begin{bmatrix} x \\ y \\ z \end{bmatrix} \right) = \begin{bmatrix} -2x - 3y - 3z \\ 3x + 4y + 4z \\ 3x + 4y + 5z \end{bmatrix} \quad \text{and} \quad Q \left(\begin{bmatrix} x \\ y \\ z \end{bmatrix} \right) = \begin{bmatrix} x - 4y + 9z \\ y - 2z \\ 8y^2 - 3xz \end{bmatrix}.$$

Which do you *suspect*?

- A. P is linear, but Q is not.
- B. Q is linear, but P is not.
- C. Both maps are linear.
- D. Neither map is linear.

- (b) Consider the following map of Euclidean vectors $S : \mathbb{R}^2 \rightarrow \mathbb{R}^2$

$$S \left(\begin{bmatrix} x \\ y \end{bmatrix} \right) = \begin{bmatrix} x + 2y \\ 9xy \end{bmatrix}.$$

Prove that S is *not* a linear transformation.

(c) Consider the following map of Euclidean vectors $T : \mathbb{R}^2 \rightarrow \mathbb{R}^2$

$$T \left(\begin{bmatrix} x \\ y \end{bmatrix} \right) = \begin{bmatrix} 8x - 6y \\ 6x - 4y \end{bmatrix}.$$

Prove that T is a linear transformation.

3.1.3 Individual Practice

Activity 3.1.11 Let $f(x) = x^3 - 1$. Then, $f: \mathbb{R} \rightarrow \mathbb{R}$ is a function with domain and codomain equal to \mathbb{R} . Is $f(x)$ a linear transformation?

Activity 3.1.12

- (a) Is it the case that rotating $\vec{u} + \vec{v}$ about the origin by $\frac{\pi}{2} = 90^\circ$ is the same as first rotating each of \vec{u}, \vec{v} and then adding them together?
- (b) Is it the case that rotating $5\vec{u}$ about the origin by $\frac{\pi}{2} = 90^\circ$ is the same as first rotating \vec{u} by $\frac{\pi}{2} = 90^\circ$ and then scaling by 5?
- (c) Based on this, do you suspect that the transformation $R: \mathbb{R}^2 \rightarrow \mathbb{R}^2$ given by rotating vectors about the origin through an angle of $\frac{\pi}{2} = 90^\circ$ is linear? Do you think there is anything special about the angle $\frac{\pi}{2} = 90^\circ$?

Activity 3.1.13 In [Activity 2.2.1](#), we made an analogy between vectors and linear combinations with ingredients and recipes. Let us think of *cooking* as a transformation of ingredients. In this analogy, would it be appropriate for us to consider "cooking" to be a linear transformation or not? Describe your reasoning.

3.1.4 Videos



[Standalone](#)

Figure 21 Video: Showing a transformation is linear

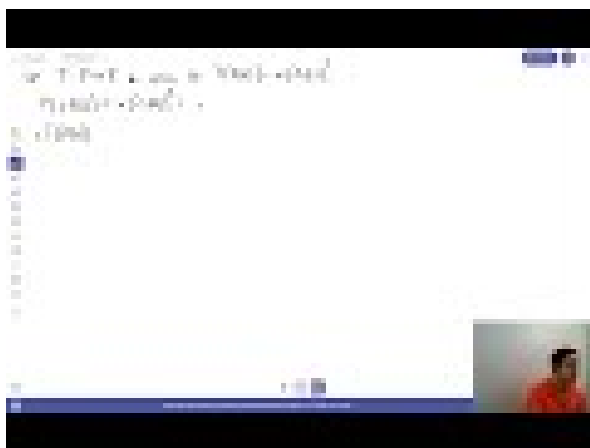

Standalone

Figure 22 Video: Showing a transformation is not linear

3.1.5 Exercises

Exercises available at <https://tbil.org/linear-algebra/preview/exercises/#/bank/AT1/>.

3.1.6 Mathematical Writing Explorations

Exploration 3.1.14 If V, W are vector spaces, with associated zero vectors $\vec{0}_V$ and $\vec{0}_W$, and $T : V \rightarrow W$ is a linear transformation, does $T(\vec{0}_V) = \vec{0}_W$? Prove this is true, or find a counterexample.

Exploration 3.1.15 Assume $f : V \rightarrow W$ is a linear transformation between vector spaces. Let $\vec{v} \in V$ with additive inverse \vec{v}^{-1} . Prove that $f(\vec{v}^{-1}) = [f(\vec{v})]^{-1}$.

3.1.7 Sample Problem and Solution

Sample problem [Example B.1.12](#).

3.2 Standard Matrices (AT2)

Learning Outcomes

- Translate back and forth between a linear transformation of Euclidean spaces and its standard matrix, and perform related computations.

3.2.1 Warm Up

Remark 3.2.1 Recall that a linear map $T : V \rightarrow W$ satisfies

1. $T(\vec{v} + \vec{w}) = T(\vec{v}) + T(\vec{w})$ for any $\vec{v}, \vec{w} \in V$.
2. $T(c\vec{v}) = cT(\vec{v})$ for any $c \in \mathbb{R}, \vec{v} \in V$.

In other words, a map is linear when vector space operations can be applied before or after the transformation without affecting the result.

Activity 3.2.2 Can you recall the following?

- (a) Given a transformation, what do the terms *domain* and *codomain* mean?
- (b) What does the notation $T: V \rightarrow W$ mean?

3.2.2 Class Activities

Activity 3.2.3 Suppose $T: \mathbb{R}^3 \rightarrow \mathbb{R}^2$ is a linear map, and you know $T\left(\begin{bmatrix} 1 \\ 0 \\ 0 \end{bmatrix}\right) = \begin{bmatrix} 2 \\ 1 \end{bmatrix}$

and $T\left(\begin{bmatrix} 0 \\ 0 \\ 1 \end{bmatrix}\right) = \begin{bmatrix} -3 \\ 2 \end{bmatrix}$. What is $T\left(\begin{bmatrix} 3 \\ 0 \\ 0 \end{bmatrix}\right)$?

- A. $\begin{bmatrix} 6 \\ 3 \end{bmatrix}$
- B. $\begin{bmatrix} -9 \\ 6 \end{bmatrix}$
- C. $\begin{bmatrix} -4 \\ -2 \end{bmatrix}$
- D. $\begin{bmatrix} 6 \\ -4 \end{bmatrix}$

Activity 3.2.4 Suppose $T: \mathbb{R}^3 \rightarrow \mathbb{R}^2$ is a linear map, and you know $T\left(\begin{bmatrix} 1 \\ 0 \\ 0 \end{bmatrix}\right) = \begin{bmatrix} 2 \\ 1 \end{bmatrix}$

and $T\left(\begin{bmatrix} 0 \\ 0 \\ 1 \end{bmatrix}\right) = \begin{bmatrix} -3 \\ 2 \end{bmatrix}$. What is $T\left(\begin{bmatrix} 1 \\ 0 \\ 1 \end{bmatrix}\right)$?

- A. $\begin{bmatrix} 2 \\ 1 \end{bmatrix}$
- B. $\begin{bmatrix} 3 \\ -1 \end{bmatrix}$
- C. $\begin{bmatrix} -1 \\ 3 \end{bmatrix}$
- D. $\begin{bmatrix} 5 \\ -8 \end{bmatrix}$

Activity 3.2.5 Suppose $T: \mathbb{R}^3 \rightarrow \mathbb{R}^2$ is a linear map, and you know $T\left(\begin{bmatrix} 1 \\ 0 \\ 0 \end{bmatrix}\right) = \begin{bmatrix} 2 \\ 1 \end{bmatrix}$

and $T\left(\begin{bmatrix} 0 \\ 0 \\ 1 \end{bmatrix}\right) = \begin{bmatrix} -3 \\ 2 \end{bmatrix}$. What is $T\left(\begin{bmatrix} -2 \\ 0 \\ -3 \end{bmatrix}\right)$?

- A. $\begin{bmatrix} 2 \\ 1 \end{bmatrix}$
- B. $\begin{bmatrix} 3 \\ -1 \end{bmatrix}$
- C. $\begin{bmatrix} -1 \\ 3 \end{bmatrix}$
- D. $\begin{bmatrix} 5 \\ -8 \end{bmatrix}$

Activity 3.2.6 Suppose $T : \mathbb{R}^3 \rightarrow \mathbb{R}^2$ is a linear map, and you know $T \left(\begin{bmatrix} 1 \\ 0 \\ 0 \end{bmatrix} \right) = \begin{bmatrix} 2 \\ 1 \end{bmatrix}$ and $T \left(\begin{bmatrix} 0 \\ 0 \\ 1 \end{bmatrix} \right) = \begin{bmatrix} -3 \\ 2 \end{bmatrix}$. What piece of information would help you compute $T \left(\begin{bmatrix} 0 \\ 4 \\ -1 \end{bmatrix} \right)$?

A. The value of $T \left(\begin{bmatrix} 0 \\ -4 \\ 0 \end{bmatrix} \right)$.

C. The value of $T \left(\begin{bmatrix} 1 \\ 1 \\ 1 \end{bmatrix} \right)$.

B. The value of $T \left(\begin{bmatrix} 0 \\ 1 \\ 0 \end{bmatrix} \right)$.

D. Any of the above.

Fact 3.2.7 Consider any basis $\{\vec{b}_1, \dots, \vec{b}_n\}$ for V . Since every vector \vec{v} can be written as a linear combination of basis vectors, $\vec{v} = x_1\vec{b}_1 + \dots + x_n\vec{b}_n$, we may compute $T(\vec{v})$ as follows:

$$T(\vec{v}) = T(x_1\vec{b}_1 + \dots + x_n\vec{b}_n) = x_1T(\vec{b}_1) + \dots + x_nT(\vec{b}_n).$$

Therefore any linear transformation $T : V \rightarrow W$ can be defined by just describing the values of $T(\vec{b}_i)$.

Put another way, the images of the basis vectors completely **determine** the transformation T .

Definition 3.2.8 Since a linear transformation $T : \mathbb{R}^n \rightarrow \mathbb{R}^m$ is determined by its action on the standard basis $\{\vec{e}_1, \dots, \vec{e}_n\}$, it is convenient to store this information in an $m \times n$ matrix, called the **standard matrix** of T , given by $[T(\vec{e}_1) \ \dots \ T(\vec{e}_n)]$.

For example, let $T : \mathbb{R}^3 \rightarrow \mathbb{R}^2$ be the linear map determined by the following values for T applied to the standard basis of \mathbb{R}^3 .

$$T(\vec{e}_1) = T \left(\begin{bmatrix} 1 \\ 0 \\ 0 \end{bmatrix} \right) = \begin{bmatrix} 3 \\ 2 \end{bmatrix} \quad T(\vec{e}_2) = T \left(\begin{bmatrix} 0 \\ 1 \\ 0 \end{bmatrix} \right) = \begin{bmatrix} -1 \\ 4 \end{bmatrix} \quad T(\vec{e}_3) = T \left(\begin{bmatrix} 0 \\ 0 \\ 1 \end{bmatrix} \right) = \begin{bmatrix} 5 \\ 0 \end{bmatrix}$$

Then the standard matrix corresponding to T is

$$[T(\vec{e}_1) \ T(\vec{e}_2) \ T(\vec{e}_3)] = \begin{bmatrix} 3 & -1 & 5 \\ 2 & 4 & 0 \end{bmatrix}.$$

◇

Activity 3.2.9 Let $T : \mathbb{R}^4 \rightarrow \mathbb{R}^3$ be the linear transformation given by

$$T(\vec{e}_1) = \begin{bmatrix} 0 \\ 3 \\ -2 \end{bmatrix} \quad T(\vec{e}_2) = \begin{bmatrix} -3 \\ 0 \\ 1 \end{bmatrix} \quad T(\vec{e}_3) = \begin{bmatrix} 4 \\ -2 \\ 1 \end{bmatrix} \quad T(\vec{e}_4) = \begin{bmatrix} 2 \\ 0 \\ 0 \end{bmatrix}$$

Write the standard matrix $[T(\vec{e}_1) \cdots T(\vec{e}_n)]$ for T .

Activity 3.2.10 Let $T : \mathbb{R}^3 \rightarrow \mathbb{R}^2$ be the linear transformation given by

$$T \left(\begin{bmatrix} x \\ y \\ z \end{bmatrix} \right) = \begin{bmatrix} x + 3z \\ 2x - y - 4z \end{bmatrix}$$

(a) Compute $T(\vec{e}_1)$, $T(\vec{e}_2)$, and $T(\vec{e}_3)$.

(b) Find the standard matrix for T .

Fact 3.2.11 Because every linear map $T : \mathbb{R}^n \rightarrow \mathbb{R}^m$ has a linear combination of the variables in each component, and thus $T(\vec{e}_i)$ yields exactly the coefficients of x_i , the standard matrix for T is simply an array of the coefficients of the x_i :

$$T \left(\begin{bmatrix} x \\ y \\ z \\ w \end{bmatrix} \right) = \begin{bmatrix} ax + by + cz + dw \\ ex + fy + gz + hw \end{bmatrix} \quad A = \begin{bmatrix} a & b & c & d \\ e & f & g & h \end{bmatrix}$$

Since the formula for a linear transformation T and its standard matrix A may both be used to compute the transformation of a vector \vec{x} , we will often write $T(\vec{x})$ and $A\vec{x}$ interchangeably:

$$T \left(\begin{bmatrix} x_1 \\ x_2 \\ x_3 \\ x_4 \end{bmatrix} \right) = \begin{bmatrix} ax_1 + bx_2 + cx_3 + dx_4 \\ ex_1 + fx_2 + gx_3 + hx_4 \end{bmatrix} = A \begin{bmatrix} x_1 \\ x_2 \\ x_3 \\ x_4 \end{bmatrix} = \begin{bmatrix} a & b & c & d \\ e & f & g & h \end{bmatrix} \begin{bmatrix} x_1 \\ x_2 \\ x_3 \\ x_4 \end{bmatrix}$$

Activity 3.2.12 Let $T : \mathbb{R}^3 \rightarrow \mathbb{R}^3$ be the linear transformation given by the standard matrix

$$\begin{bmatrix} 3 & -2 & -1 \\ 4 & 5 & 2 \\ 0 & -2 & 1 \end{bmatrix}.$$

(a) Compute $T \left(\begin{bmatrix} 1 \\ 2 \\ 3 \end{bmatrix} \right)$.

(b) Compute $T \left(\begin{bmatrix} x \\ y \\ z \end{bmatrix} \right)$.

Activity 3.2.13 Compute the following linear transformations of vectors given their standard matrices.

(a)

$$T_1 \left(\begin{bmatrix} 1 \\ 2 \end{bmatrix} \right) \text{ for the standard matrix } A_1 = \begin{bmatrix} 4 & 3 \\ 0 & -1 \\ 1 & 1 \\ 3 & 0 \end{bmatrix}$$

(b)

$$T_2 \left(\begin{bmatrix} 1 \\ 1 \\ 0 \\ -3 \end{bmatrix} \right) \text{ for the standard matrix } A_2 = \begin{bmatrix} 4 & 3 & 0 & -1 \\ 1 & 1 & 3 & 0 \end{bmatrix}$$

(c)

$$T_3 \left(\begin{bmatrix} 0 \\ -2 \\ 0 \end{bmatrix} \right) \text{ for the standard matrix } A_3 = \begin{bmatrix} 4 & 3 & 0 \\ 0 & -1 & 3 \\ 5 & 1 & 1 \\ 3 & 0 & 0 \end{bmatrix}$$

3.2.3 Individual Practice

Activity 3.2.14 Consider the linear transformation $R: \mathbb{R}^2 \rightarrow \mathbb{R}^2$ given by rotating vectors about the origin through an angle of $\frac{\pi}{4} = 45^\circ$.

(a) If \vec{e}_1, \vec{e}_2 are the standard basis vectors of \mathbb{R}^2 , calculate $R(\vec{e}_1), R(\vec{e}_2)$.

(b) What is the standard matrix representing R ?

Activity 3.2.15 Consider the linear transformation $S: \mathbb{R}^2 \rightarrow \mathbb{R}^2$ given by reflecting vectors across the line $x_1 = x_2$.

(a) If \vec{e}_1, \vec{e}_2 are the standard basis vectors of \mathbb{R}^2 , calculate $S(\vec{e}_1), S(\vec{e}_2)$.

(b) What is the standard matrix representing S ?

3.2.4 Videos



Standalone

Figure 23 Video: Using the standard matrix to compute the image of a vector

3.2.5 Exercises

Exercises available at <https://tbil.org/linear-algebra/preview/exercises/#/bank/AT2/>.

3.2.6 Mathematical Writing Explorations

We can represent images in the plane \mathbb{R}^2 using vectors, and manipulate those images with linear transformations. We introduce some notation in these explorations that is needed for their completion, but is not essential to the rest of the text. These have a geometric flair to them, and can be understood by thinking of geometric transformations in terms of standard matrices.

Given two vectors $\vec{v} = \begin{bmatrix} v_1 \\ v_2 \\ \vdots \\ v_n \end{bmatrix}$ and $\vec{w} = \begin{bmatrix} w_1 \\ w_2 \\ \vdots \\ w_n \end{bmatrix}$, we define the **dot product** as

$$\vec{v} \cdot \vec{w} = v_1w_1 + v_2w_2 + \cdots v_nw_n.$$

Exploration 3.2.16 For each of the following properties, determine if it is held by the dot product. Either provide a proof if the property holds, or provide a counter-example if it does not.

- Distributive over addition (e.g., $(\vec{u} + \vec{v}) \cdot \vec{w} = \vec{u} \cdot \vec{w} + \vec{v} \cdot \vec{w}$)?
- Associative?
- Commutative?

Exploration 3.2.17 Given the properties you proved in the last exploration, could the dot product take the place of \oplus as a vector space operation on \mathbb{R}^n ?

Exploration 3.2.18 Is the dot product a linear operator? That is, given vectors $\vec{u}, \vec{v}, \vec{w} \in \mathbb{R}^n$, and $k, m \in \mathbb{R}$, is it true that

$$\vec{u} \cdot (k\vec{v} + m\vec{w}) = k(\vec{u} \cdot \vec{v}) + m(\vec{u} \cdot \vec{w}).$$

Prove or provide a counter-example.

Exploration 3.2.19 Assume $\vec{v} = \begin{bmatrix} v_1 \\ v_2 \\ \vdots \\ v_n \end{bmatrix}$ and define the length of a vector by

$$|\vec{v}| = \left(\sum_{i=1}^n v_i^2 \right)^{1/2}.$$

Prove that $|\vec{u}| = |\vec{v}|$ if and only if $\vec{u} + \vec{v}$ and $\vec{u} - \vec{v}$ are perpendicular. You may use the fact (try and prove it!) that two vectors are perpendicular if and only if their dot product is zero.

Exploration 3.2.20

- A **dilation** is given by mapping a vector $\vec{v} = \begin{bmatrix} x \\ y \end{bmatrix}$ to some scalar multiple of \vec{v} .
- A **rotation** is given by $\vec{v} \mapsto \begin{bmatrix} \cos(\theta)x - \sin(\theta)y \\ \cos(\theta)y + \sin(\theta)x \end{bmatrix}$.
- A **reflection** of \vec{v} over a line l can be found by first finding a vector $\vec{l} = \begin{bmatrix} l_x \\ l_y \end{bmatrix}$ along l , then $\vec{v} \mapsto 2\frac{\vec{l}\vec{v}}{\vec{l}\vec{l}} - \vec{v}$.

Represent each of the following transformations with respect to the standard basis in \mathbb{R}^2 .

- Rotation through an angle θ .
- Reflection over a line l passing through the origin.
- Dilation by some scalar s .

Prove that each transformation is linear, and that your matrix representations are correct.

3.2.7 Sample Problem and Solution

Sample problem [Example B.1.13](#).

3.3 Image and Kernel (AT3)

Learning Outcomes

- Compute a basis for the kernel and a basis for the image of a linear map, and verify that the rank-nullity theorem holds for a given linear map.

3.3.1 Warm Up

Activity 3.3.1 Consider the matrix $A = \begin{bmatrix} 3 & 4 & 7 & 1 \\ -1 & 1 & 0 & 2 \\ 2 & 1 & 3 & -1 \end{bmatrix}$.

- The matrix A is the standard matrix of a linear transformation T . What is the domain and the codomain of the transformation T ?
- Describe how T transforms the standard basis vectors of the domain that you found above.

3.3.2 Class Activities

Activity 3.3.2 Let $T : \mathbb{R}^2 \rightarrow \mathbb{R}^3$ be given by

$$T\left(\begin{bmatrix} x \\ y \end{bmatrix}\right) = \begin{bmatrix} x \\ y \\ 0 \end{bmatrix} \quad \text{with standard matrix} \quad \begin{bmatrix} 1 & 0 \\ 0 & 1 \\ 0 & 0 \end{bmatrix}$$

Which of these subspaces of \mathbb{R}^2 describes the set of all vectors that transform into $\vec{0}$?

- | | |
|--|---|
| A. $\left\{ \begin{bmatrix} a \\ a \end{bmatrix} \mid a \in \mathbb{R} \right\}$ | C. $\left\{ \begin{bmatrix} 0 \\ 0 \end{bmatrix} \right\}$ |
| B. $\left\{ \begin{bmatrix} a \\ 0 \end{bmatrix} \mid a \in \mathbb{R} \right\}$ | D. $\left\{ \begin{bmatrix} a \\ b \end{bmatrix} \mid a, b \in \mathbb{R} \right\}$ |

Definition 3.3.3 Let $T : V \rightarrow W$ be a linear transformation, and let \vec{z} be the additive identity (the “zero vector”) of W . The **kernel** of T is an important subspace of V defined by

$$\ker T = \{ \vec{v} \in V \mid T(\vec{v}) = \vec{z} \}$$

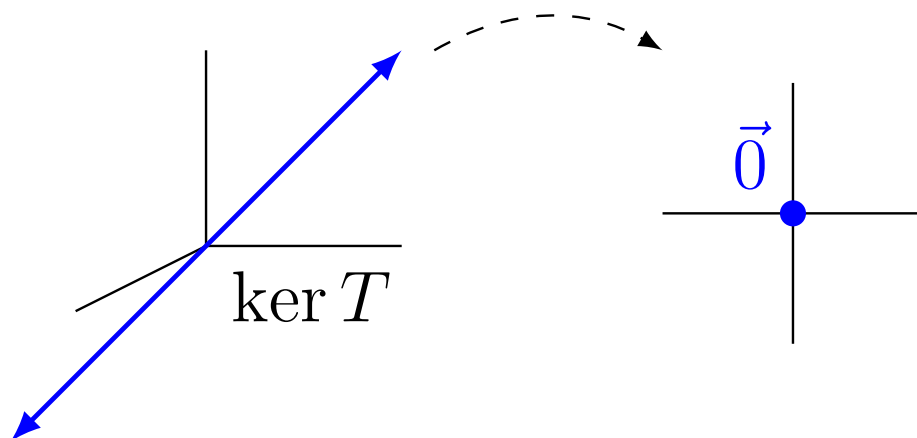

Figure 24 The kernel of a linear transformation

◇

Activity 3.3.4 Let $T : \mathbb{R}^3 \rightarrow \mathbb{R}^2$ be given by

$$T \left(\begin{bmatrix} x \\ y \\ z \end{bmatrix} \right) = \begin{bmatrix} x \\ y \end{bmatrix} \quad \text{with standard matrix} \quad \begin{bmatrix} 1 & 0 & 0 \\ 0 & 1 & 0 \end{bmatrix}$$

Which of these subspaces of \mathbb{R}^3 describes $\ker T$, the set of all vectors that transform into $\vec{0}$?

- A. $\left\{ \begin{bmatrix} 0 \\ 0 \\ a \end{bmatrix} \mid a \in \mathbb{R} \right\}$ C. $\left\{ \begin{bmatrix} 0 \\ 0 \\ 0 \end{bmatrix} \right\}$
- B. $\left\{ \begin{bmatrix} a \\ a \\ 0 \end{bmatrix} \mid a \in \mathbb{R} \right\}$ D. $\left\{ \begin{bmatrix} a \\ b \\ c \end{bmatrix} \mid a, b, c \in \mathbb{R} \right\}$

Activity 3.3.5 Let $T : \mathbb{R}^3 \rightarrow \mathbb{R}^2$ be the linear transformation given by the standard matrix

$$T \left(\begin{bmatrix} x \\ y \\ z \end{bmatrix} \right) = \begin{bmatrix} 3x + 4y - z \\ x + 2y + z \end{bmatrix}$$

- (a) Set $T \left(\begin{bmatrix} x \\ y \\ z \end{bmatrix} \right) = \begin{bmatrix} 0 \\ 0 \end{bmatrix}$ to find a linear system of equations whose solution set is the kernel.
- (b) Use $\text{RREF}(A)$ to solve this homogeneous system of equations and find a basis for the kernel of T .

Activity 3.3.6 Let $T : \mathbb{R}^4 \rightarrow \mathbb{R}^3$ be the linear transformation given by

$$T \left(\begin{bmatrix} x \\ y \\ z \\ w \end{bmatrix} \right) = \begin{bmatrix} 2x + 4y + 2z - 4w \\ -2x - 4y + z + w \\ 3x + 6y - z - 4w \end{bmatrix}.$$

Find a basis for the kernel of T .

Activity 3.3.7 Let $T : \mathbb{R}^2 \rightarrow \mathbb{R}^3$ be given by

$$T \left(\begin{bmatrix} x \\ y \end{bmatrix} \right) = \begin{bmatrix} x \\ y \\ 0 \end{bmatrix} \quad \text{with standard matrix} \quad \begin{bmatrix} 1 & 0 \\ 0 & 1 \\ 0 & 0 \end{bmatrix}$$

Which of these subspaces of \mathbb{R}^3 describes the set of all vectors that are the result of using T to transform \mathbb{R}^2 vectors?

A. $\left\{ \begin{bmatrix} 0 \\ 0 \\ a \end{bmatrix} \mid a \in \mathbb{R} \right\}$

C. $\left\{ \begin{bmatrix} 0 \\ 0 \\ 0 \end{bmatrix} \right\}$

B. $\left\{ \begin{bmatrix} a \\ b \\ 0 \end{bmatrix} \mid a, b \in \mathbb{R} \right\}$

D. $\left\{ \begin{bmatrix} a \\ b \\ c \end{bmatrix} \mid a, b, c \in \mathbb{R} \right\}$

Definition 3.3.8 Let $T : V \rightarrow W$ be a linear transformation. The **image** of T is an important subspace of W defined by

$$\text{Im } T = \{ \vec{w} \in W \mid \text{there is some } \vec{v} \in V \text{ with } T(\vec{v}) = \vec{w} \}$$

In the examples below, the left example's image is all of \mathbb{R}^2 , but the right example's image is a planar subspace of \mathbb{R}^3 .

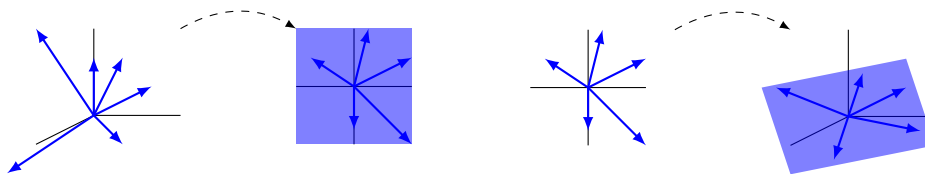

Figure 25 The image of a linear transformation

◇

Activity 3.3.9 Let $T : \mathbb{R}^3 \rightarrow \mathbb{R}^2$ be given by

$$T \left(\begin{bmatrix} x \\ y \\ z \end{bmatrix} \right) = \begin{bmatrix} x \\ y \end{bmatrix} \quad \text{with standard matrix} \quad \begin{bmatrix} 1 & 0 & 0 \\ 0 & 1 & 0 \end{bmatrix}$$

Which of these subspaces of \mathbb{R}^2 describes $\text{Im } T$, the set of all vectors that are the result of using T to transform \mathbb{R}^3 vectors?

- A. $\left\{ \begin{bmatrix} a \\ a \end{bmatrix} \mid a \in \mathbb{R} \right\}$ C. $\left\{ \begin{bmatrix} 0 \\ 0 \end{bmatrix} \right\}$
- B. $\left\{ \begin{bmatrix} a \\ 0 \end{bmatrix} \mid a \in \mathbb{R} \right\}$ D. $\left\{ \begin{bmatrix} a \\ b \end{bmatrix} \mid a, b \in \mathbb{R} \right\}$

Activity 3.3.10 Let $T : \mathbb{R}^4 \rightarrow \mathbb{R}^3$ be the linear transformation given by the standard matrix

$$A = \begin{bmatrix} 3 & 4 & 7 & 1 \\ -1 & 1 & 0 & 2 \\ 2 & 1 & 3 & -1 \end{bmatrix} = [T(\vec{e}_1) \quad T(\vec{e}_2) \quad T(\vec{e}_3) \quad T(\vec{e}_4)].$$

Consider the question: Which vectors \vec{w} in \mathbb{R}^3 belong to $\text{Im } T$?

- (a) Determine if $\begin{bmatrix} 12 \\ 3 \\ 3 \end{bmatrix}$ belongs to $\text{Im } T$.
- (b) Determine if $\begin{bmatrix} 1 \\ 1 \\ 1 \end{bmatrix}$ belongs to $\text{Im } T$.
- (c) An arbitrary vector $\begin{bmatrix} ? \\ ? \\ ? \end{bmatrix}$ belongs to $\text{Im } T$ provided the equation
- $$x_1T(\vec{e}_1) + x_2T(\vec{e}_2) + x_3T(\vec{e}_3) + x_4T(\vec{e}_4) = \vec{w}$$

has...

- A. no solutions.
- B. exactly one solution.
- C. at least one solution.
- D. infinitely-many solutions.
- (d) Based on this, how do $\text{Im } T$ and $\text{span} \{T(\vec{e}_1), T(\vec{e}_2), T(\vec{e}_3), T(\vec{e}_4)\}$ relate to each other?
- A. The set $\text{Im } T$ contains $\text{span} \{T(\vec{e}_1), T(\vec{e}_2), T(\vec{e}_3), T(\vec{e}_4)\}$ but is not equal to it.
- B. The set $\text{span} \{T(\vec{e}_1), T(\vec{e}_2), T(\vec{e}_3), T(\vec{e}_4)\}$ contains $\text{Im } T$ but is not equal to it.
- C. The set $\text{Im } T$ and $\text{span} \{T(\vec{e}_1), T(\vec{e}_2), T(\vec{e}_3), T(\vec{e}_4)\}$ are equal to each other.
- D. There is no relation between these two sets.

Observation 3.3.11 Let $T : \mathbb{R}^4 \rightarrow \mathbb{R}^3$ be the linear transformation given by the standard matrix

$$A = \begin{bmatrix} 3 & 4 & 7 & 1 \\ -1 & 1 & 0 & 2 \\ 2 & 1 & 3 & -1 \end{bmatrix}.$$

Since the set $\left\{ \begin{bmatrix} 3 \\ -1 \\ 2 \end{bmatrix}, \begin{bmatrix} 4 \\ 1 \\ 1 \end{bmatrix}, \begin{bmatrix} 7 \\ 0 \\ 3 \end{bmatrix}, \begin{bmatrix} 1 \\ 2 \\ -1 \end{bmatrix} \right\}$ spans $\text{Im } T$, we can obtain a basis for $\text{Im } T$ by finding RREF $A = \begin{bmatrix} 1 & 0 & 1 & -1 \\ 0 & 1 & 1 & 1 \\ 0 & 0 & 0 & 0 \end{bmatrix}$ and only using the vectors corresponding to pivot columns:

$$\left\{ \begin{bmatrix} 3 \\ -1 \\ 2 \end{bmatrix}, \begin{bmatrix} 4 \\ 1 \\ 1 \end{bmatrix} \right\}$$

Fact 3.3.12 Let $T : \mathbb{R}^n \rightarrow \mathbb{R}^m$ be a linear transformation with standard matrix A .

- The kernel of T is the solution set of the homogeneous system given by the augmented matrix $[A \mid \vec{0}]$. Use the coefficients of its free variables to get a basis for the kernel (as in [Fact 2.7.4](#)).
- The image of T is the span of the columns of A . Remove the vectors creating non-pivot columns in RREF A to get a basis for the image (as in [Observation 2.6.5](#)).

Activity 3.3.13 Let $T : \mathbb{R}^3 \rightarrow \mathbb{R}^4$ be the linear transformation given by the standard matrix

$$A = \begin{bmatrix} 1 & -3 & 2 \\ 2 & -6 & 0 \\ 0 & 0 & 1 \\ -1 & 3 & 1 \end{bmatrix}.$$

Find a basis for the kernel and a basis for the image of T .

Activity 3.3.14 Let $T : \mathbb{R}^n \rightarrow \mathbb{R}^m$ be a linear transformation with standard matrix A . Which of the following is equal to the dimension of the kernel of T ?

- The number of pivot columns
- The number of non-pivot columns
- The number of pivot rows
- The number of non-pivot rows

Activity 3.3.15 Let $T : \mathbb{R}^n \rightarrow \mathbb{R}^m$ be a linear transformation with standard matrix A . Which of the following is equal to the dimension of the image of T ?

- The number of pivot columns
- The number of non-pivot columns
- The number of pivot rows
- The number of non-pivot rows

Observation 3.3.16 Combining these with the observation that the number of columns is the dimension of the domain of T , we have the **rank-nullity theorem**:

The dimension of the domain of T equals $\dim(\ker T) + \dim(\operatorname{Im} T)$.

The dimension of the image is called the **rank** of T (or A) and the dimension of the kernel is called the **nullity**.

Activity 3.3.17 Let $T : \mathbb{R}^4 \rightarrow \mathbb{R}^3$ be the linear transformation given by

$$T \left(\begin{bmatrix} x \\ y \\ z \\ w \end{bmatrix} \right) = \begin{bmatrix} x - y + 5z + 3w \\ -x - 4z - 2w \\ y - 2z - w \end{bmatrix}.$$

- Explain and demonstrate how to find the image of T and a basis for that image.
- Explain and demonstrate how to find the kernel of T and a basis for that kernel.
- Explain and demonstrate how to find the rank and nullity of T , and why the rank-nullity theorem holds for T .

3.3.3 Individual Practice

Activity 3.3.18 In this section, we've introduced two important subspaces that are associated with a linear transformation $T : V \rightarrow W$, namely: $\operatorname{Im} T$, the image of T , and $\ker T$, the kernel of T . The following sequence is designed to help you internalize these definitions. Try to complete them without referring to your Activity Book, and then check your answers.

- One of $\ker T$ and $\operatorname{Im} T$ is a subspace of the domain and the other is a subspace of the codomain. Which is which?
- Write down the precise definitions of these subspaces.
- How would you describe these definitions to a layperson?
- What picture, or other study strategy would be helpful to you in conceptualizing how these definitions fit together?

3.3.4 Videos

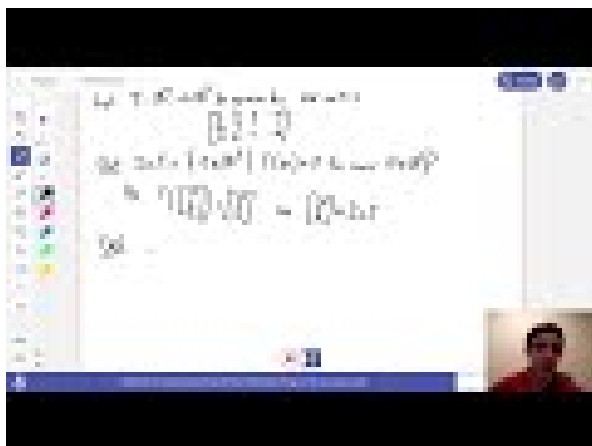

[Standalone](#)

Figure 26 Video: The kernel and image of a linear transformation

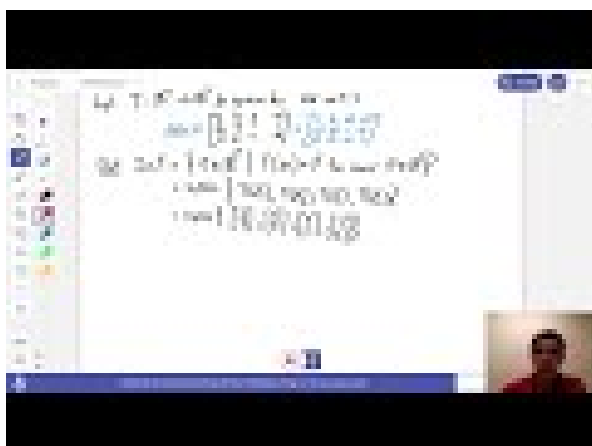

[Standalone](#)

Figure 27 Video: Finding a basis of the image of a linear transformation

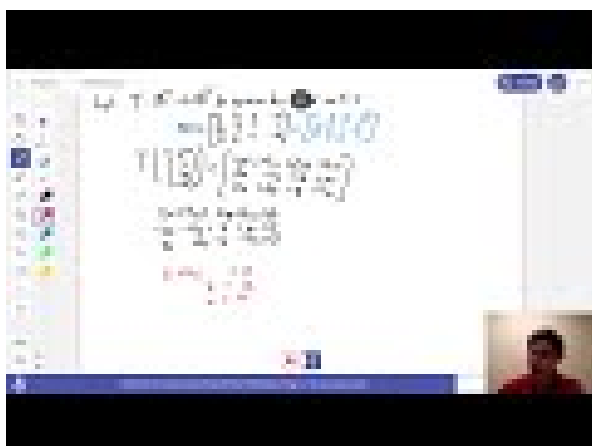

[Standalone](#)

Figure 28 Video: Finding a basis of the kernel of a linear transformation



Standalone

Figure 29 Video: The rank-nullity theorem

3.3.5 Exercises

Exercises available at <https://tbil.org/linear-algebra/preview/exercises/#/bank/AT3/>.

3.3.6 Mathematical Writing Explorations

Exploration 3.3.19 Assume $f : V \rightarrow W$ is a linear map. Let $\{\vec{v}_1, \vec{v}_2, \dots, \vec{v}_n\}$ be a set of vectors in V , and set $\vec{w}_i = f(\vec{v}_i)$.

- If the set $\{\vec{w}_1, \vec{w}_2, \dots, \vec{w}_n\}$ is linearly independent, must the set $\{\vec{v}_1, \vec{v}_2, \dots, \vec{v}_n\}$ also be linearly independent?
- If the set $\{\vec{v}_1, \vec{v}_2, \dots, \vec{v}_n\}$ is linearly independent, must the set $\{\vec{w}_1, \vec{w}_2, \dots, \vec{w}_n\}$ also be linearly independent?
- If the set $\{\vec{w}_1, \vec{w}_2, \dots, \vec{w}_n\}$ spans W , must the set $\{\vec{v}_1, \vec{v}_2, \dots, \vec{v}_n\}$ also span V ?
- If the set $\{\vec{v}_1, \vec{v}_2, \dots, \vec{v}_n\}$ spans V , must the set $\{\vec{w}_1, \vec{w}_2, \dots, \vec{w}_n\}$ also span W ?
- In light of this, is the image of the basis of a vector space always a basis for the codomain?

Exploration 3.3.20 Prove the Rank-Nullity Theorem. Use the steps below to help you.

- The theorem states that, given a linear map $h : V \rightarrow W$, with V and W vector spaces, the rank of h , plus the nullity of h , equals the dimension of the domain V . Assume that the dimension of V is n .
- For simplicity, denote the rank of h by $\mathcal{R}(h)$, and the nullity by $\mathcal{N}(h)$.
- Recall that $\mathcal{R}(h)$ is the dimension of the range space of h . State the precise definition.
- Recall that $\mathcal{N}(h)$ is the dimension of the null space of h . State the precise definition.
- Begin with a basis for the null space, denoted $B_N = \{\vec{\beta}_1, \vec{\beta}_2, \dots, \vec{\beta}_k\}$. Show how this

can be extended to a basis B_V for V , with $B_V = \{\vec{\beta}_1, \vec{\beta}_2, \dots, \vec{\beta}_k, \beta_{k+1}, \beta_{k+2}, \dots, \vec{\beta}_n\}$. In this portion, you should assume $k \leq n$, and construct additional vectors which are not linear combinations of vectors in B_N . Prove that you can always do this until you have n total linearly independent vectors.

- Show that $B_R = \{h(\vec{\beta}_{k+1}), h(\vec{\beta}_{k+2}), \dots, h(\vec{\beta}_n)\}$ is a basis for the range space. Start by showing that it is linearly independent, and be sure you prove that each element of the range space can be written as a linear combination of B_R .
- Show that B_R spans the range space.
- State your conclusion.

3.3.7 Sample Problem and Solution

Sample problem [Example B.1.14](#).

3.4 Injective and Surjective Linear Maps (AT4)

Learning Outcomes

- Determine if a given linear map is injective and/or surjective.

3.4.1 Warm Up

Activity 3.4.1 Consider the linear transformation $T: \mathbb{R}^4 \rightarrow \mathbb{R}^3$ that is represented by the standard matrix $A = \begin{bmatrix} 3 & 4 & 7 & 1 \\ -1 & 1 & 0 & 2 \\ 2 & 1 & 3 & -1 \end{bmatrix}$. Which of the following processes helps us compute a basis for $\text{Im } T$ and which helps us compute a basis for $\ker T$?

- Compute $\text{RREF}(A)$ and consider the set of columns of A that correspond to columns in $\text{RREF}(A)$ with pivots.
- Calculate a basis for the solution space to the homogenous system of equations for which A is the coefficient matrix.

3.4.2 Class Activities

Definition 3.4.2 Let $T: V \rightarrow W$ be a linear transformation. T is called **injective** or **one-to-one** if T does not map two distinct vectors to the same place. More precisely, T is injective if $T(\vec{v}) \neq T(\vec{w})$ whenever $\vec{v} \neq \vec{w}$.

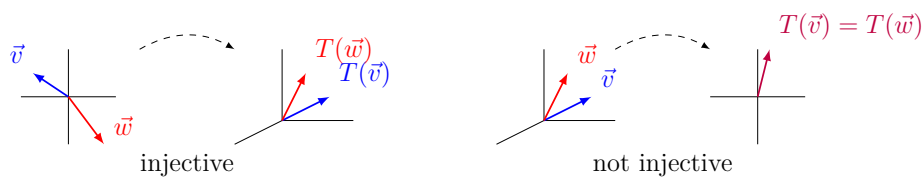

Figure 30 An injective transformation and a non-injective transformation

◇

Activity 3.4.3 Let $T : \mathbb{R}^3 \rightarrow \mathbb{R}^2$ be given by

$$T \left(\begin{bmatrix} x \\ y \\ z \end{bmatrix} \right) = \begin{bmatrix} x \\ y \end{bmatrix} \quad \text{with standard matrix} \quad \begin{bmatrix} 1 & 0 & 0 \\ 0 & 1 & 0 \end{bmatrix}$$

Is T injective?

A. Yes, because $T(\vec{v}) = T(\vec{w})$ whenever $\vec{v} = \vec{w}$.

B. Yes, because $T(\vec{v}) \neq T(\vec{w})$ whenever $\vec{v} \neq \vec{w}$.

C. No, because $T \left(\begin{bmatrix} 0 \\ 0 \\ 1 \end{bmatrix} \right) \neq T \left(\begin{bmatrix} 0 \\ 0 \\ 2 \end{bmatrix} \right)$.

D. No, because $T \left(\begin{bmatrix} 0 \\ 0 \\ 1 \end{bmatrix} \right) = T \left(\begin{bmatrix} 0 \\ 0 \\ 2 \end{bmatrix} \right)$.

Activity 3.4.4 Let $T : \mathbb{R}^2 \rightarrow \mathbb{R}^3$ be given by

$$T \left(\begin{bmatrix} x \\ y \end{bmatrix} \right) = \begin{bmatrix} x \\ y \\ 0 \end{bmatrix} \quad \text{with standard matrix} \quad \begin{bmatrix} 1 & 0 \\ 0 & 1 \\ 0 & 0 \end{bmatrix}$$

Is T injective?

A. Yes, because $T(\vec{v}) = T(\vec{w})$ whenever $\vec{v} = \vec{w}$.

B. Yes, because $T(\vec{v}) \neq T(\vec{w})$ whenever $\vec{v} \neq \vec{w}$.

C. No, because $T \left(\begin{bmatrix} 1 \\ 2 \end{bmatrix} \right) \neq T \left(\begin{bmatrix} 3 \\ 4 \end{bmatrix} \right)$.

D. No, because $T \left(\begin{bmatrix} 1 \\ 2 \end{bmatrix} \right) = T \left(\begin{bmatrix} 3 \\ 4 \end{bmatrix} \right)$.

Definition 3.4.5 Let $T : V \rightarrow W$ be a linear transformation. T is called **surjective** or **onto** if every element of W is mapped to by an element of V . More precisely, for every $\vec{w} \in W$, there is some $\vec{v} \in V$ with $T(\vec{v}) = \vec{w}$.

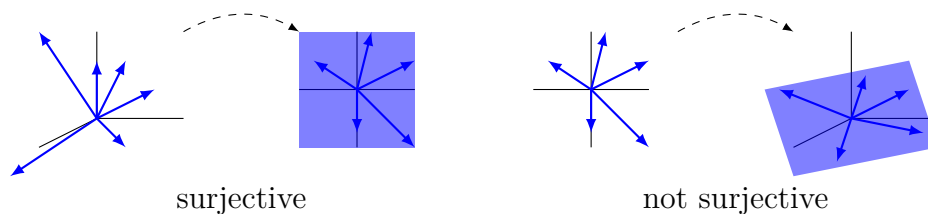

Figure 31 A surjective transformation and a non-surjective transformation

◇

Activity 3.4.6 Let $T : \mathbb{R}^2 \rightarrow \mathbb{R}^3$ be given by

$$T\left(\begin{bmatrix} x \\ y \end{bmatrix}\right) = \begin{bmatrix} x \\ y \\ 0 \end{bmatrix} \quad \text{with standard matrix} \quad \begin{bmatrix} 1 & 0 \\ 0 & 1 \\ 0 & 0 \end{bmatrix}$$

Is T surjective?

A. Yes, because for every $\vec{w} = \begin{bmatrix} x \\ y \\ z \end{bmatrix} \in \mathbb{R}^3$, there exists $\vec{v} = \begin{bmatrix} x \\ y \end{bmatrix} \in \mathbb{R}^2$ such that $T(\vec{v}) = \vec{w}$.

B. No, because $T\left(\begin{bmatrix} x \\ y \end{bmatrix}\right)$ can never equal $\begin{bmatrix} 1 \\ 1 \\ 1 \end{bmatrix}$.

C. No, because $T\left(\begin{bmatrix} x \\ y \end{bmatrix}\right)$ can never equal $\begin{bmatrix} 0 \\ 0 \\ 0 \end{bmatrix}$.

Activity 3.4.7 Let $T : \mathbb{R}^3 \rightarrow \mathbb{R}^2$ be given by

$$T\left(\begin{bmatrix} x \\ y \\ z \end{bmatrix}\right) = \begin{bmatrix} x \\ y \end{bmatrix} \quad \text{with standard matrix} \quad \begin{bmatrix} 1 & 0 & 0 \\ 0 & 1 & 0 \end{bmatrix}$$

Is T surjective?

A. Yes, because for every $\vec{w} = \begin{bmatrix} x \\ y \end{bmatrix} \in \mathbb{R}^2$, there exists $\vec{v} = \begin{bmatrix} x \\ y \\ 42 \end{bmatrix} \in \mathbb{R}^3$ such that $T(\vec{v}) = \vec{w}$.

B. Yes, because for every $\vec{w} = \begin{bmatrix} x \\ y \end{bmatrix} \in \mathbb{R}^2$, there exists $\vec{v} = \begin{bmatrix} 0 \\ 0 \\ z \end{bmatrix} \in \mathbb{R}^3$ such that $T(\vec{v}) = \vec{w}$.

C. No, because $T \left(\begin{bmatrix} x \\ y \\ z \end{bmatrix} \right)$ can never equal $\begin{bmatrix} 3 \\ -2 \end{bmatrix}$.

Activity 3.4.8 Let $T : V \rightarrow W$ be a linear transformation where $\ker T$ contains multiple vectors. What can you conclude?

- A. T is injective
- B. T is not injective
- C. T is surjective
- D. T is not surjective

Fact 3.4.9 A linear transformation T is injective if and only if $\ker T = \{\vec{0}\}$. Put another way, an injective linear transformation may be recognized by its **trivial** kernel.

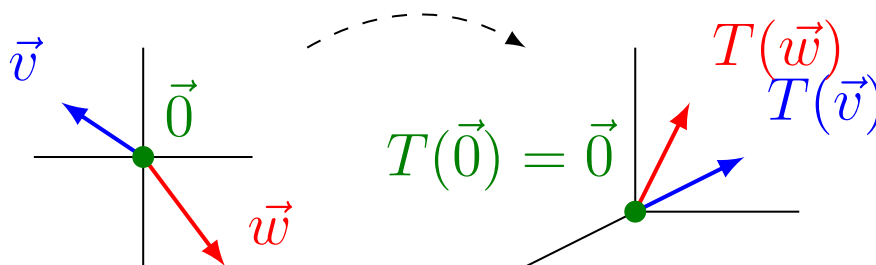

Figure 32 A linear transformation with trivial kernel, which is therefore injective

Activity 3.4.10 Let $T : V \rightarrow \mathbb{R}^3$ be a linear transformation where $\text{Im } T$ may be spanned by only two vectors. What can you conclude?

- A. T is injective
- B. T is not injective
- C. T is surjective
- D. T is not surjective

Fact 3.4.11 A linear transformation $T : V \rightarrow W$ is surjective if and only if $\text{Im } T = W$. Put another way, a surjective linear transformation may be recognized by its identical codomain and image.

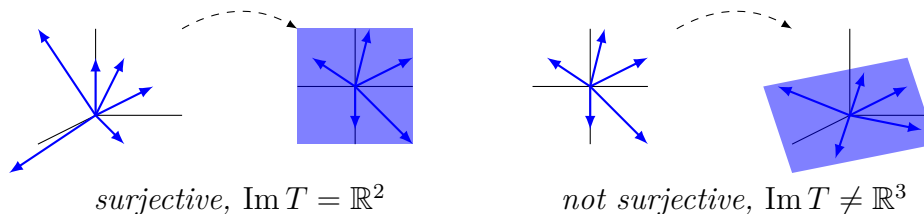

Figure 33 A linear transformation with identical codomain and image, which is therefore surjective; and a linear transformation with an image smaller than the codomain \mathbb{R}^3 , which is therefore not surjective.

Definition 3.4.12 A transformation that is both injective and surjective is said to be **bijective**. \diamond

Activity 3.4.13 Let $T : \mathbb{R}^n \rightarrow \mathbb{R}^m$ be a linear map with standard matrix A . Determine whether each of the following statements means T is (A) *injective*, (B) *surjective*, or (C)

bijective (both).

1. The kernel of T is trivial, i.e. $\ker T = \{\vec{0}\}$.
2. The image of T equals its codomain, i.e. $\text{Im } T = \mathbb{R}^m$.
3. For every $\vec{w} \in \mathbb{R}^m$, the set $\{\vec{v} \in \mathbb{R}^n | T(\vec{v}) = \vec{w}\}$ contains exactly one vector.

Activity 3.4.14 Let $T : \mathbb{R}^n \rightarrow \mathbb{R}^m$ be a linear map with standard matrix A . Determine whether each of the following statements means T is (A) *injective*, (B) *surjective*, or (C) *bijective* (both).

1. The columns of A span \mathbb{R}^m .
2. The columns of A form a basis for \mathbb{R}^m .
3. The columns of A are linearly independent.

Activity 3.4.15 Let $T : \mathbb{R}^n \rightarrow \mathbb{R}^m$ be a linear map with standard matrix A . Determine whether each of the following statements means T is (A) *injective*, (B) *surjective*, or (C) *bijective* (both).

1. $\text{RREF}(A)$ is the identity matrix.
2. Every column of $\text{RREF}(A)$ has a pivot.
3. Every row of $\text{RREF}(A)$ has a pivot.

Activity 3.4.16 Let $T : \mathbb{R}^n \rightarrow \mathbb{R}^m$ be a linear map with standard matrix A . Determine whether each of the following statements means T is (A) *injective*, (B) *surjective*, or (C) *bijective* (both).

1. The system of linear equations given by the augmented matrix $\left[A \mid \vec{b} \right]$ has a solution for all $\vec{b} \in \mathbb{R}^m$.
2. The system of linear equations given by the augmented matrix $\left[A \mid \vec{b} \right]$ has exactly one solution for all $\vec{b} \in \mathbb{R}^m$.
3. The system of linear equations given by the augmented matrix $\left[A \mid \vec{0} \right]$ has exactly one solution.

Observation 3.4.17 The easiest way to determine if the linear map with standard matrix A is injective is to see if $\text{RREF}(A)$ has a pivot in each column.

The easiest way to determine if the linear map with standard matrix A is surjective is to see if $\text{RREF}(A)$ has a pivot in each row.

Activity 3.4.18 What can you conclude about the linear map $T : \mathbb{R}^2 \rightarrow \mathbb{R}^3$ with standard matrix $\begin{bmatrix} a & b \\ c & d \\ e & f \end{bmatrix}$?

- A. Its standard matrix has more columns than rows, so T is not injective.
- B. Its standard matrix has more columns than rows, so T is injective.
- C. Its standard matrix has more rows than columns, so T is not surjective.
- D. Its standard matrix has more rows than columns, so T is surjective.

Activity 3.4.19 What can you conclude about the linear map $T : \mathbb{R}^3 \rightarrow \mathbb{R}^2$ with standard matrix $\begin{bmatrix} a & b & c \\ d & e & f \end{bmatrix}$?

- A. Its standard matrix has more columns than rows, so T is not injective.
- B. Its standard matrix has more columns than rows, so T is injective.
- C. Its standard matrix has more rows than columns, so T is not surjective.
- D. Its standard matrix has more rows than columns, so T is surjective.

Fact 3.4.20 *The following are true for any linear map $T : V \rightarrow W$:*

- *If $\dim(V) > \dim(W)$, then T is not injective.*
- *If $\dim(V) < \dim(W)$, then T is not surjective.*

Basically, a linear transformation cannot reduce dimension without collapsing vectors into each other, and a linear transformation cannot increase dimension from its domain to its image.

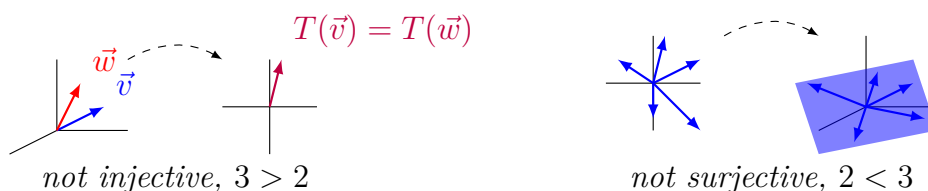

Figure 34 *A linear transformation whose domain has a larger dimension than its codomain, and is therefore not injective; and a linear transformation whose domain has a smaller dimension than its codomain, and is therefore not surjective.*

But dimension arguments cannot be used to prove a map is injective or surjective.

Activity 3.4.21 Suppose $T : \mathbb{R}^n \rightarrow \mathbb{R}^4$ with standard matrix $A = \begin{bmatrix} a_{11} & a_{12} & \cdots & a_{1n} \\ a_{21} & a_{22} & \cdots & a_{2n} \\ a_{31} & a_{32} & \cdots & a_{3n} \\ a_{41} & a_{42} & \cdots & a_{4n} \end{bmatrix}$ is bijective.

- (a) How many pivot rows must RREF A have?
- (b) How many pivot columns must RREF A have?

(c) What is RREF A ?

Activity 3.4.22 Let $T : \mathbb{R}^n \rightarrow \mathbb{R}^n$ be a bijective linear map with standard matrix A . Label each of the following as true or false.

- A. $\text{RREF}(A)$ is the identity matrix.
- B. The columns of A form a basis for \mathbb{R}^n .
- C. The system of linear equations given by the augmented matrix $\left[A \mid \vec{b} \right]$ has exactly one solution for each $\vec{b} \in \mathbb{R}^n$.

Observation 3.4.23 The easiest way to show that the linear map with standard matrix A is bijective is to show that $\text{RREF}(A)$ is the identity matrix.

Activity 3.4.24 Let $T : \mathbb{R}^3 \rightarrow \mathbb{R}^3$ be given by the standard matrix

$$A = \begin{bmatrix} 2 & 1 & -1 \\ 4 & 1 & 1 \\ 6 & 2 & 1 \end{bmatrix}.$$

Which of the following must be true?

- A. T is neither injective nor surjective
- B. T is injective but not surjective
- C. T is surjective but not injective
- D. T is bijective.

`rref([2,1,-1; 4,1,1; 6,2,1])`

Activity 3.4.25 Let $T : \mathbb{R}^3 \rightarrow \mathbb{R}^3$ be given by

$$T \left(\begin{bmatrix} x \\ y \\ z \end{bmatrix} \right) = \begin{bmatrix} 2x + y - z \\ 4x + y + z \\ 6x + 2y \end{bmatrix}.$$

Which of the following must be true?

- A. T is neither injective nor surjective
- B. T is injective but not surjective
- C. T is surjective but not injective
- D. T is bijective.

`rref([2,1,-1; 4,1,1; 6,2,0])`

Activity 3.4.26 Let $T : \mathbb{R}^2 \rightarrow \mathbb{R}^3$ be given by

$$T \left(\begin{bmatrix} x \\ y \end{bmatrix} \right) = \begin{bmatrix} 2x + 3y \\ x - y \\ x + 3y \end{bmatrix}.$$

Which of the following must be true?

- A. T is neither injective nor surjective C. T is surjective but not injective
 B. T is injective but not surjective D. T is bijective.

rref([2, 3; 1, -1; 1, 3])

Activity 3.4.27 Let $T: \mathbb{R}^3 \rightarrow \mathbb{R}^2$ be given by

$$T\left(\begin{bmatrix} x \\ y \\ z \end{bmatrix}\right) = \begin{bmatrix} 2x + y - z \\ 4x + y + z \end{bmatrix}.$$

Which of the following must be true?

- A. T is neither injective nor surjective C. T is surjective but not injective
 B. T is injective but not surjective D. T is bijective.

rref([2, 1, -1; 4, 1, 1])

3.4.2.1 Individual Practice

Activity 3.4.28 Let $T: \mathbb{R}^n \rightarrow \mathbb{R}^m$ be a linear transformation with standard matrix A . We reasoned during class that the following statements are logically equivalent:

1. The columns of A are linearly independent.
2. RREF(A) has a pivot in each column.
3. The transformation T is injective.
4. The system of equations given by $[A|\vec{0}]$ has a unique solution.

While they are all logically equivalent, they are different statements that offer varied perspectives on our growing conceptual knowledge of linear algebra.

- (a) If you are asked to decide if a transformation T is injective, which of the above statements do you think is the most useful?
- (b) Can you think of some situations in which translating between these four statements might be useful to you?

Activity 3.4.29 Let $T: \mathbb{R}^n \rightarrow \mathbb{R}^m$ be a linear transformation with standard matrix A . We reasoned during class that the following statements are logically equivalent:

1. The columns of A span all of \mathbb{R}^m .
2. RREF(A) has a pivot in each row.
3. The transformation T is surjective.

4. The system of equations given by $[A|\vec{b}]$ is always consistent.

While they are all logically equivalent, they are different statements that offer varied perspectives on our growing conceptual knowledge of linear algebra.

- (a) If you are asked to decide if a transformation T is surjective, which of the above statements do you think is the most useful?
- (b) Can you think of some situations in which translating between these four statements might be useful to you?

3.4.3 Videos

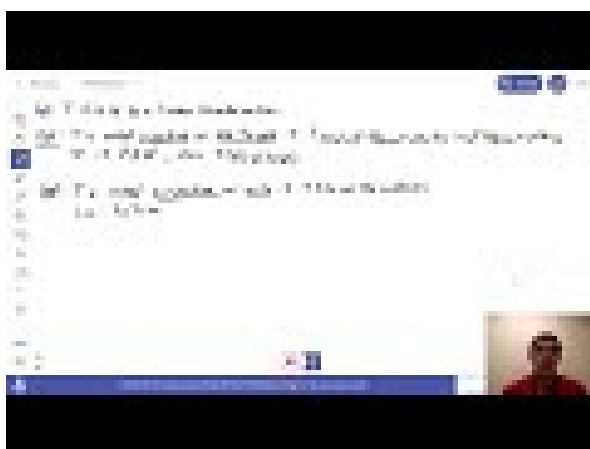

Standalone

Figure 35 Video: The kernel and image of a linear transformation



Standalone

Figure 36 Video: Finding a basis of the image of a linear transformation

3.4.4 Exercises

Exercises available at <https://tbil.org/linear-algebra/preview/exercises/#/bank/AT4/>.

3.4.5 Mathematical Writing Explorations

Exploration 3.4.30 Suppose that $f : V \rightarrow W$ is a linear transformation between two vector spaces V and W . State carefully what conditions f must satisfy. Let $\vec{0}_V$ and $\vec{0}_W$ be the zero vectors in V and W respectively.

- Prove that f is one-to-one if and only if $f(\vec{0}_V) = \vec{0}_W$, and that $\vec{0}_V$ is the unique element of V which is mapped to $\vec{0}_W$. Remember that this needs to be done in both directions. First prove the if and only if statement, and then show the uniqueness.
- Do not use subtraction in your proof. The only vector space operation we have is addition, and a structure preserving function only preserves addition. If you are writing $\vec{v} - \vec{v} = \vec{0}_V$, what you really mean is that $\vec{v} \oplus \vec{v}^{-1} = \vec{0}_V$, where \vec{v}^{-1} is the additive inverse of \vec{v} .

Exploration 3.4.31 Start with an n -dimensional vector space V . We can define the **dual** of V , denoted V^* , by

$$V^* = \{h : V \rightarrow \mathbb{R} : h \text{ is linear}\}.$$

Prove that V is isomorphic to V^* . Here are some things to think about as you work through this.

- Start by assuming you have a basis for V . How many basis vectors should you have?
- For each basis vector in V , define a function that returns 1 if it's given that basis vector, and returns 0 if it's given any other basis vector. For example, if \vec{b}_i and \vec{b}_j are each members of the basis for V , and you'll need a function $f_i : V \rightarrow \{0, 1\}$, where $f_i(\vec{b}_i) = 1$ and $f_i(\vec{b}_j) = 0$ for all $j \neq i$.
- How many of these functions will you need? Show that each of them is in V^* .
- Show that the functions you found in the last part are a basis for V^* ? To do this, take an arbitrary function $h \in V^*$ and some vector $\vec{v} \in V$. Write \vec{v} in terms of the basis you chose earlier. How can you write $h(\vec{v})$, with respect to that basis? Pay attention to the fact that all functions in V^* are linear.
- Now that you've got a basis for V and a basis for V^* , can you find an isomorphism?

3.4.6 Sample Problem and Solution

Sample problem [Example B.1.15](#).

3.5 Vector Spaces (AT5)

Learning Outcomes

- Explain why a given set with defined addition and scalar multiplication does satisfy a given vector space property, but nonetheless isn't a vector space.

3.5.1 Warm Up

Activity 3.5.1

- How would you describe a sandwich to someone who has never seen a sandwich before?
- How would you describe to someone what a vector is?

3.5.2 Class Activities

Observation 3.5.2 Consider the following applications of properties of the real numbers \mathbb{R} :

- $1 + (2 + 3) = (1 + 2) + 3$.
- $7 + 4 = 4 + 7$.
- There exists some $?$ where $5 + ? = 5$.
- There exists some $?$ where $9 + ? = 0$.
- $\frac{1}{2}(1 + 7)$ is the only number that is equally distant from 1 and 7.

Activity 3.5.3 Which of the following properties of \mathbb{R}^2 Euclidean vectors is NOT true?

- $\begin{bmatrix} x_1 \\ x_2 \end{bmatrix} + \left(\begin{bmatrix} y_1 \\ y_2 \end{bmatrix} + \begin{bmatrix} z_1 \\ z_2 \end{bmatrix} \right) = \left(\begin{bmatrix} x_1 \\ x_2 \end{bmatrix} + \begin{bmatrix} y_1 \\ y_2 \end{bmatrix} \right) + \begin{bmatrix} z_1 \\ z_2 \end{bmatrix}$.
- $\begin{bmatrix} x_1 \\ x_2 \end{bmatrix} + \begin{bmatrix} y_1 \\ y_2 \end{bmatrix} = \begin{bmatrix} y_1 \\ y_2 \end{bmatrix} + \begin{bmatrix} x_1 \\ x_2 \end{bmatrix}$.
- There exists some $\begin{bmatrix} ? \\ ? \end{bmatrix}$ where $\begin{bmatrix} x_1 \\ x_2 \end{bmatrix} + \begin{bmatrix} ? \\ ? \end{bmatrix} = \begin{bmatrix} x_1 \\ x_2 \end{bmatrix}$.
- There exists some $\begin{bmatrix} ? \\ ? \end{bmatrix}$ where $\begin{bmatrix} x_1 \\ x_2 \end{bmatrix} + \begin{bmatrix} ? \\ ? \end{bmatrix} = \begin{bmatrix} 0 \\ 0 \end{bmatrix}$.
- $\frac{1}{2} \left(\begin{bmatrix} x_1 \\ x_2 \end{bmatrix} + \begin{bmatrix} y_1 \\ y_2 \end{bmatrix} \right)$ is the only vector whose endpoint is equally distant from the endpoints of $\begin{bmatrix} x_1 \\ x_2 \end{bmatrix}$ and $\begin{bmatrix} y_1 \\ y_2 \end{bmatrix}$.

Observation 3.5.4 Consider the following applications of properties of the real numbers \mathbb{R} :

1. $3(2(7)) = (3 \cdot 2)(7)$.
2. $1(19) = 19$.
3. There exists some x such that $x \cdot 4 = 9$.
4. $3 \cdot (2 + 8) = 3 \cdot 2 + 3 \cdot 8$.
5. $(2 + 7) \cdot 4 = 2 \cdot 4 + 7 \cdot 4$.

Activity 3.5.5 Which of the following properties of \mathbb{R}^2 Euclidean vectors is NOT true?

- A. $a \left(b \begin{bmatrix} x_1 \\ x_2 \end{bmatrix} \right) = ab \begin{bmatrix} x_1 \\ x_2 \end{bmatrix}$.
- B. $1 \begin{bmatrix} x_1 \\ x_2 \end{bmatrix} = \begin{bmatrix} x_1 \\ x_2 \end{bmatrix}$.
- C. There exists some x such that $x \begin{bmatrix} x_1 \\ x_2 \end{bmatrix} = \begin{bmatrix} y_1 \\ y_2 \end{bmatrix}$.
- D. $a(\vec{u} + \vec{v}) = a\vec{u} + a\vec{v}$.
- E. $(a + b)\vec{v} = a\vec{v} + b\vec{v}$.

Fact 3.5.6 Every Euclidean vector space \mathbb{R}^n satisfies the following properties, where $\vec{u}, \vec{v}, \vec{w}$ are Euclidean vectors and a, b are scalars.

1. Vector addition is associative: $\vec{u} + (\vec{v} + \vec{w}) = (\vec{u} + \vec{v}) + \vec{w}$.
2. Vector addition is commutative: $\vec{u} + \vec{v} = \vec{v} + \vec{u}$.
3. An additive identity exists: There exists some \vec{z} where $\vec{v} + \vec{z} = \vec{v}$.
4. Additive inverses exist: There exists some $-\vec{v}$ where $\vec{v} + (-\vec{v}) = \vec{z}$.
5. Scalar multiplication is associative: $a(b\vec{v}) = (ab)\vec{v}$.
6. 1 is a multiplicative identity: $1\vec{v} = \vec{v}$.
7. Scalar multiplication distributes over vector addition: $a(\vec{u} + \vec{v}) = (a\vec{u}) + (a\vec{v})$.
8. Scalar multiplication distributes over scalar addition: $(a + b)\vec{v} = (a\vec{v}) + (b\vec{v})$.

Definition 3.5.7 A **vector space** V is any set of mathematical objects, called **vectors**, and a set of numbers, called **scalars**, with associated addition \oplus and scalar multiplication \odot operations that satisfy the following properties. Let $\vec{u}, \vec{v}, \vec{w}$ be vectors belonging to V , and let a, b be scalars.

We always assume the codomain of our operations is V , i.e. that addition is a map $V \times V \rightarrow V$ and that scalar multiplication is a map $\mathbb{R} \times V \rightarrow V$.

Likewise, we only consider “real” vector spaces, i.e. those whose scalars come from \mathbb{R} . However, one can similarly define vector spaces with scalars from other fields like the complex or rational numbers.

1. Vector addition is associative: $\vec{u} \oplus (\vec{v} \oplus \vec{w}) = (\vec{u} \oplus \vec{v}) \oplus \vec{w}$.
2. Vector addition is commutative: $\vec{u} \oplus \vec{v} = \vec{v} \oplus \vec{u}$.
3. An additive identity exists: There exists some \vec{z} where $\vec{v} \oplus \vec{z} = \vec{v}$.
4. Additive inverses exist: There exists some $-\vec{v}$ where $\vec{v} \oplus (-\vec{v}) = \vec{z}$.
5. Scalar multiplication is associative: $a \odot (b \odot \vec{v}) = (ab) \odot \vec{v}$.
6. 1 is a multiplicative identity: $1 \odot \vec{v} = \vec{v}$.
7. Scalar multiplication distributes over vector addition: $a \odot (\vec{u} \oplus \vec{v}) = (a \odot \vec{u}) \oplus (a \odot \vec{v})$.
8. Scalar multiplication distributes over scalar addition: $(a + b) \odot \vec{v} = (a \odot \vec{v}) \oplus (b \odot \vec{v})$.

◇

Remark 3.5.8 Consider the set \mathbb{C} of complex numbers with the usual definition for addition: $(a + b\mathbf{i}) \oplus (c + d\mathbf{i}) = (a + c) + (b + d)\mathbf{i}$.

Let $\vec{u} = a + b\mathbf{i}$, $\vec{v} = c + d\mathbf{i}$, and $\vec{w} = e + f\mathbf{i}$. Then

$$\begin{aligned}\vec{u} \oplus (\vec{v} \oplus \vec{w}) &= (a + b\mathbf{i}) \oplus ((c + d\mathbf{i}) \oplus (e + f\mathbf{i})) \\ &= (a + b\mathbf{i}) \oplus ((c + e) + (d + f)\mathbf{i}) \\ &= (a + c + e) + (b + d + f)\mathbf{i}\end{aligned}$$

$$\begin{aligned}(\vec{u} \oplus \vec{v}) \oplus \vec{w} &= ((a + b\mathbf{i}) \oplus (c + d\mathbf{i})) \oplus (e + f\mathbf{i}) \\ &= ((a + c) + (b + d)\mathbf{i}) \oplus (e + f\mathbf{i}) \\ &= (a + c + e) + (b + d + f)\mathbf{i}\end{aligned}$$

This proves that complex addition is associative: $\vec{u} \oplus (\vec{v} \oplus \vec{w}) = (\vec{u} \oplus \vec{v}) \oplus \vec{w}$. The seven other vector space properties may also be verified, so \mathbb{C} is an example of a vector space.

Remark 3.5.9 The following sets are just a few examples of vector spaces, with the usual/natural operations for addition and scalar multiplication.

- \mathbb{R}^n : Euclidean vectors with n components.
- \mathbb{C} : Complex numbers.
- $M_{m,n}$: Matrices of real numbers with m rows and n columns.
- \mathcal{P}_n : Polynomials of degree n or less.

- \mathcal{P} : Polynomials of any degree.
- $C(\mathbb{R})$: Real-valued continuous functions.

Activity 3.5.10 Consider the set $V = \{(x, y) \mid y = 2^x\}$.
Which of the following vectors is not in V ?

- | | |
|-------------|-------------|
| A. $(0, 0)$ | C. $(2, 4)$ |
| B. $(1, 2)$ | D. $(3, 8)$ |

Activity 3.5.11 Consider the set $V = \{(x, y) \mid y = 2^x\}$ with the operation \oplus defined by

$$(x_1, y_1) \oplus (x_2, y_2) = (x_1 + x_2, y_1 y_2).$$

Let \vec{u}, \vec{v} be in V with $\vec{u} = (1, 2)$ and $\vec{v} = (2, 4)$. Using the operations defined for V , which of the following is $\vec{u} \oplus \vec{v}$?

- | | |
|-------------|-------------|
| A. $(2, 6)$ | C. $(3, 6)$ |
| B. $(2, 8)$ | D. $(3, 8)$ |

Activity 3.5.12 Consider the set $V = \{(x, y) \mid y = 2^x\}$ with operations \oplus, \odot defined by

$$(x_1, y_1) \oplus (x_2, y_2) = (x_1 + x_2, y_1 y_2) \quad c \odot (x, y) = (cx, y^c).$$

Let $a = 2, b = -3$ be scalars and $\vec{u} = (1, 2) \in V$.

(a) Verify that

$$(a + b) \odot \vec{u} = \left(-1, \frac{1}{2}\right).$$

(b) Compute the value of

$$(a \odot \vec{u}) \oplus (b \odot \vec{u}).$$

Activity 3.5.13 Consider the set $V = \{(x, y) \mid y = 2^x\}$ with operations \oplus, \odot defined by

$$(x_1, y_1) \oplus (x_2, y_2) = (x_1 + x_2, y_1 y_2) \quad c \odot (x, y) = (cx, y^c).$$

Let a, b be unspecified scalars in \mathbb{R} and $\vec{u} = (x, y)$ be an unspecified vector in V .

(a) Show that both sides of the equation

$$(a + b) \odot (x, y) = (a \odot (x, y)) \oplus (b \odot (x, y))$$

simplify to the expression $(ax + bx, y^a y^b)$.

(b) Show that V contains an additive identity element $\vec{z} = (?, ?)$ satisfying

$$(x, y) \oplus (?, ?) = (x, y)$$

for all $(x, y) \in V$.

That is, pick appropriate values for $\vec{z} = (?, ?)$ and then simplify $(x, y) \oplus (?, ?)$ into just (x, y) .

(c) Is V a vector space?

- A. Yes
- B. No
- C. More work is required

Remark 3.5.14 It turns out $V = \{(x, y) \mid y = 2^x\}$ with operations \oplus, \odot defined by

$$(x_1, y_1) \oplus (x_2, y_2) = (x_1 + x_2, y_1 y_2) \quad c \odot (x, y) = (cx, y^c)$$

satisfies all eight properties from [Definition 3.5.7](#).

Thus, V is a vector space.

Activity 3.5.15 Let $V = \{(x, y) \mid x, y \in \mathbb{R}\}$ have operations defined by

$$(x_1, y_1) \oplus (x_2, y_2) = (x_1 + y_1 + x_2 + y_2, x_1^2 + x_2^2)$$

$$c \odot (x, y) = (x^c, y + c - 1).$$

- (a) Show that 1 is the scalar multiplication identity element by simplifying $1 \odot (x, y)$ to (x, y) .
- (b) Show that V does not have an additive identity element $\vec{z} = (z, w)$ by showing that $(0, -1) \oplus (z, w) \neq (0, -1)$ no matter what the values of z, w are.
- (c) Is V a vector space?
 - A. Yes
 - B. No
 - C. More work is required

Activity 3.5.16 Let $V = \{(x, y) \mid x, y \in \mathbb{R}\}$ have operations defined by

$$(x_1, y_1) \oplus (x_2, y_2) = (x_1 + x_2, y_1 + 3y_2) \quad c \odot (x, y) = (cx, cy).$$

(a) Show that scalar multiplication distributes over vector addition, i.e.

$$c \odot ((x_1, y_1) \oplus (x_2, y_2)) = c \odot (x_1, y_1) \oplus c \odot (x_2, y_2)$$

for all $c \in \mathbb{R}$, $(x_1, y_1), (x_2, y_2) \in V$.

(b) Show that vector addition is not associative, i.e.

$$(x_1, y_1) \oplus ((x_2, y_2) \oplus (x_3, y_3)) \neq ((x_1, y_1) \oplus (x_2, y_2)) \oplus (x_3, y_3)$$

for some vectors $(x_1, y_1), (x_2, y_2), (x_3, y_3) \in V$.

(c) Is V a vector space?

- A. Yes
- B. No
- C. More work is required

3.5.3 Cooldown

Activity 3.5.17

- (a) What are some objects that are important to you personally, academically, or otherwise that appear vector-like to you? What makes them feel vector-like? Which axiom for vector spaces does not hold for these objects, if any.
- (b) Our vector space axioms have eight properties. While these eight properties are enough to capture vectors, the objects that we study in the real-world often have additional structures not captured by these axioms. What are some structures that you have encountered in other classes, or in previous experiences, that are not captured by these eight axioms?

3.5.4 Videos



[Standalone](#)

Figure 37 Video: Verifying that a vector space property holds



[Standalone](#)

Figure 38 Video: Showing something is not a vector space

3.5.5 Exercises

Exercises available at <https://tbil.org/linear-algebra/preview/exercises/#/bank/AT5/>.

3.5.6 Mathematical Writing Explorations

Exploration 3.5.18

- Show that \mathbb{R}^+ , the set of positive real numbers, is a vector space, but where $x \oplus y$ really means the product (so $2 \oplus 3 = 6$), and where scalar multiplication $\alpha \odot x$ really means x^α . Yes, you really do need to check all of the properties, but this is the only time I'll make you do so. Remember, examples aren't proofs, so you should start with arbitrary elements of \mathbb{R}^+ for your vectors. Make sure you're careful about telling the reader what α means.
- Prove that the additive identity \vec{z} in an arbitrary vector space is unique.
- Prove that additive inverses are unique. Assume you have a vector space V and some $\vec{v} \in V$. Further, assume $\vec{w}_1, \vec{w}_2 \in V$ with $\vec{v} \oplus \vec{w}_1 = \vec{v} \oplus \vec{w}_2 = \vec{z}$. Prove that $\vec{w}_1 = \vec{w}_2$.

Exploration 3.5.19 Consider the vector space of polynomials, \mathcal{P}_n . Suppose further that $n = ab$, where a and b are each positive integers. Conjecture a relationship between $M_{a,b}$ and \mathcal{P}_n . We will investigate this further in section [Section 3.6](#)

3.5.7 Sample Problem and Solution

Sample problem [Example B.1.16](#).

3.6 Polynomial and Matrix Spaces (AT6)

Learning Outcomes

- Answer questions about vector spaces of polynomials or matrices.

3.6.1 Warm Up

Activity 3.6.1 Consider the following vector equation and statements about it:

$$x_1\vec{v}_1 + x_2\vec{v}_2 + \cdots + x_n\vec{v}_n = \vec{w}$$

1. The above vector equation is consistent for every choice of \vec{w} .
2. When the right hand is equal to $\vec{0}$, the equation has a unique solution.
3. The given equation always has a unique solution, no matter what \vec{w} is.

Which, if any, of these statements make sense if we no longer assume that the vectors $\vec{v}_1, \dots, \vec{v}_n$ are Euclidean vectors, but rather elements of a vector space?

3.6.2 Class Activities

Observation 3.6.2 Nearly every term we've defined for Euclidean vector spaces \mathbb{R}^n was actually defined for all kinds of vector spaces:

- [Definition 2.1.3](#)
- [Definition 2.1.4](#)
- [Definition 2.3.7](#)
- [Definition 2.4.3](#)
- [Definition 2.5.5](#)
- [Definition 3.1.3](#)
- [Definition 3.1.4](#)
- [Definition 3.3.3](#)
- [Definition 3.3.8](#)
- [Definition 3.4.2](#)
- [Definition 3.4.5](#)
- [Definition 3.4.12](#)

Activity 3.6.3 Let V be a vector space with the basis $\{\vec{v}_1, \vec{v}_2, \vec{v}_3\}$. Which of these completes the following definition for a bijective linear map $T : V \rightarrow \mathbb{R}^3$?

$$T(\vec{v}) = T(a\vec{v}_1 + b\vec{v}_2 + c\vec{v}_3) = \begin{bmatrix} ? \\ ? \\ ? \end{bmatrix}$$

A. $\begin{bmatrix} 0 \\ 0 \\ 0 \end{bmatrix}$

B. $\begin{bmatrix} a + b + c \\ 0 \\ 0 \end{bmatrix}$

C. $\begin{bmatrix} a \\ b \\ c \end{bmatrix}$

Fact 3.6.4 Every vector space with finite dimension, that is, every vector space V with a basis of the form $\{\vec{v}_1, \vec{v}_2, \dots, \vec{v}_n\}$ has a linear bijection T with Euclidean space \mathbb{R}^n that simply swaps its basis with the standard basis $\{\vec{e}_1, \vec{e}_2, \dots, \vec{e}_n\}$ for \mathbb{R}^n :

$$T(c_1\vec{v}_1 + c_2\vec{v}_2 + \cdots + c_n\vec{v}_n) = c_1\vec{e}_1 + c_2\vec{e}_2 + \cdots + c_n\vec{e}_n = \begin{bmatrix} c_1 \\ c_2 \\ \vdots \\ c_n \end{bmatrix}$$

This transformation (in fact, any linear bijection between vector spaces) is called an **isomor-**

phism, and V is said to be **isomorphic** to \mathbb{R}^n .

Note, in particular, that every vector space of dimension n is isomorphic to \mathbb{R}^n .

Activity 3.6.5 The matrix space $M_{2,2} = \left\{ \begin{bmatrix} a & b \\ c & d \end{bmatrix} \mid a, b, c, d \in \mathbb{R} \right\}$ has the basis

$$\left\{ \begin{bmatrix} 1 & 0 \\ 0 & 0 \end{bmatrix}, \begin{bmatrix} 0 & 1 \\ 0 & 0 \end{bmatrix}, \begin{bmatrix} 0 & 0 \\ 1 & 0 \end{bmatrix}, \begin{bmatrix} 0 & 0 \\ 0 & 1 \end{bmatrix} \right\}.$$

(a) What is the dimension of $M_{2,2}$?

- | | |
|------|------|
| A. 2 | C. 4 |
| B. 3 | D. 5 |

(b) Which Euclidean space is $M_{2,2}$ isomorphic to?

- | | |
|-------------------|-------------------|
| A. \mathbb{R}^2 | C. \mathbb{R}^4 |
| B. \mathbb{R}^3 | D. \mathbb{R}^5 |

(c) Describe an isomorphism $T : M_{2,2} \rightarrow \mathbb{R}^?$:

$$T \left(\begin{bmatrix} a & b \\ c & d \end{bmatrix} \right) = \begin{bmatrix} ? \\ \vdots \\ ? \end{bmatrix}$$

Activity 3.6.6 The polynomial space $\mathcal{P}^4 = \{a + bx + cx^2 + dx^3 + ex^4 \mid a, b, c, d, e \in \mathbb{R}\}$ has the basis

$$\{1, x, x^2, x^3, x^4\}.$$

(a) What is the dimension of \mathcal{P}^4 ?

- | | |
|------|------|
| A. 2 | C. 4 |
| B. 3 | D. 5 |

(b) Which Euclidean space is \mathcal{P}^4 isomorphic to?

- | | |
|-------------------|-------------------|
| A. \mathbb{R}^2 | C. \mathbb{R}^4 |
| B. \mathbb{R}^3 | D. \mathbb{R}^5 |

(c) Describe an isomorphism $T : \mathcal{P}^4 \rightarrow \mathbb{R}^?$:

$$T(a + bx + cx^2 + dx^3 + ex^4) = \begin{bmatrix} ? \\ \vdots \\ ? \end{bmatrix}$$

Remark 3.6.7 Since any finite-dimensional vector space is isomorphic to a Euclidean space \mathbb{R}^n , one approach to answering questions about such spaces is to answer the corresponding question about \mathbb{R}^n .

Activity 3.6.8 Consider how to construct the polynomial $x^3 + x^2 + 5x + 1$ as a linear combination of polynomials from the set

$$\{x^3 - 2x^2 + x + 2, 2x^2 - 1, -x^3 + 3x^2 + 3x - 2, x^3 - 6x^2 + 9x + 5\}.$$

- Describe the vector space involved in this problem, and an isomorphic Euclidean space and relevant Euclidean vectors that can be used to solve this problem.
- Show how to construct an appropriate Euclidean vector from an appropriate set of Euclidean vectors.
- Use this result to answer the original question.

Observation 3.6.9 The space of polynomials \mathcal{P} (of *any* degree) has the basis $\{1, x, x^2, x^3, \dots\}$, so it is a natural example of an infinite-dimensional vector space.

Since \mathcal{P} and other infinite-dimensional vector spaces cannot be treated as an isomorphic finite-dimensional Euclidean space \mathbb{R}^n , vectors in such vector spaces cannot be studied by converting them into Euclidean vectors. Fortunately, most of the examples we will be interested in for this course will be finite-dimensional.

3.6.3 Individual Practice

Activity 3.6.10 Let $A = \begin{bmatrix} -2 & -1 & 1 \\ 1 & 0 & 0 \\ 0 & -4 & -2 \\ 0 & 1 & 3 \end{bmatrix}$ and let $T: \mathbb{R}^3 \rightarrow \mathbb{R}^4$ denote the corresponding linear transformation. Note that

$$\text{RREF}(A) = \begin{bmatrix} 1 & 0 & 0 \\ 0 & 1 & 0 \\ 0 & 0 & 1 \\ 0 & 0 & 0 \end{bmatrix}.$$

The following statements are all *invalid* for at least one reason. Determine what makes them invalid and, suggest alternative *valid* statements that the author may have meant instead.

- The matrix A is injective because $\text{RREF}(A)$ has a pivot in each column.

- (b) The matrix A does not span \mathbb{R}^4 because $\text{RREF}(A)$ has a row of zeroes.
- (c) The transformation T does not span \mathbb{R}^4 .
- (d) The transformation T is linearly independent.

3.6.4 Videos



Standalone

Figure 39 Video: Polynomial and matrix calculations

3.6.5 Exercises

Exercises available at <https://tbil.org/linear-algebra/preview/exercises/#/bank/AT6/>.

3.6.6 Mathematical Writing Explorations

Exploration 3.6.11 Given a matrix M

- the span of the set of all columns is the **column space**
- the span of the set of all rows is the **row space**
- the **rank** of a matrix is the dimension of the column space.

Calculate the rank of these matrices.

- $\begin{bmatrix} 2 & 1 & 3 \\ 1 & -1 & 2 \\ 1 & 0 & 3 \end{bmatrix}$

- $\begin{bmatrix} 1 & -1 & 2 & 3 \\ 3 & -3 & 6 & 3 \\ -2 & 2 & 4 & 5 \end{bmatrix}$

- $\begin{bmatrix} 1 & 3 & 2 \\ 5 & 1 & 1 \\ 6 & 4 & 3 \end{bmatrix}$

$$\bullet \begin{bmatrix} 0 & 0 & 0 \\ 0 & 0 & 0 \\ 0 & 0 & 0 \end{bmatrix}$$

Exploration 3.6.12 Calculate a basis for the row space and a basis for the column space

of the matrix $\begin{bmatrix} 2 & 0 & 3 & 4 \\ 0 & 1 & 1 & -1 \\ 3 & 1 & 0 & 2 \\ 10 & -4 & -1 & -1 \end{bmatrix}$.

Exploration 3.6.13 If you are given the values of a , b , and c , what value of d will cause the matrix $\begin{bmatrix} a & b \\ c & d \end{bmatrix}$ to have rank 1?

3.6.7 Sample Problem and Solution

Sample problem [Example B.1.17](#).

Chapter 4

Matrices (MX)

Learning Outcomes

What algebraic structure do matrices have?

By the end of this chapter, you should be able to...

1. Multiply matrices.
2. Determine if a matrix is invertible, and if so, compute its inverse.
3. Invert an appropriate matrix to solve a system of linear equations.
4. Express row operations through matrix multiplication.

Readiness Assurance. Before beginning this chapter, you should be able to...

1. Compose functions of real numbers.
 - Review: [Khan Academy](#)¹
2. Identify the domain and codomain of linear transformations.
 - Review: [YouTube](#)²
3. Find the matrix corresponding to a linear transformation and compute the image of a vector given a standard matrix.
 - Review: [Section 3.2](#)
4. Determine if a linear transformation is injective and/or surjective.
 - Review: [Section 3.4](#)
5. Interpret the ideas of injectivity and surjectivity in multiple ways.

¹www.khanacademy.org/math/precalculus/composite/composing/v/function-composition

²www.youtube.com/watch?v=BQMyeQOLvpg

- Review: [YouTube](#)³

4.1 Matrices and Multiplication (MX1)

Learning Outcomes

- Multiply matrices.

4.1.1 Warm Up

Activity 4.1.1 Suppose that $T: V \rightarrow W$ is a linear transformation.

- What is the definition of $\ker T$? How does it relate to the codomain of T ?
- What is definition of $\text{Im } T$? How does it relate to the codomain of T ?

4.1.2 Class Activities

Observation 4.1.2 If $T: \mathbb{R}^n \rightarrow \mathbb{R}^m$ and $S: \mathbb{R}^m \rightarrow \mathbb{R}^k$ are linear maps, then the composition map $S \circ T$ computed as $(S \circ T)(\vec{v}) = S(T(\vec{v}))$ is a linear map from $\mathbb{R}^n \rightarrow \mathbb{R}^k$.

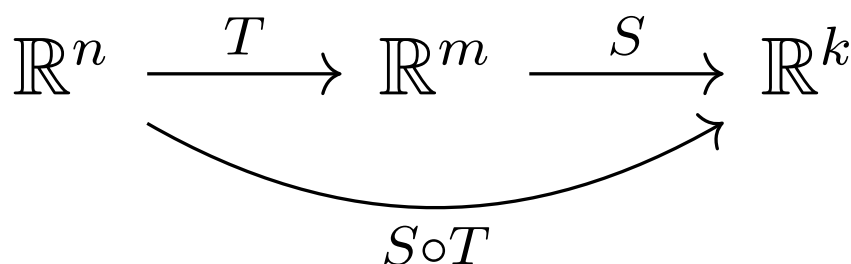

Figure 40 The composition of two linear maps.

Activity 4.1.3 Let $T: \mathbb{R}^3 \rightarrow \mathbb{R}^2$ be defined by the 2×3 standard matrix B and $S: \mathbb{R}^2 \rightarrow \mathbb{R}^4$ be defined by the 4×2 standard matrix A :

$$B = \begin{bmatrix} 2 & 1 & -3 \\ 5 & -3 & 4 \end{bmatrix} \quad A = \begin{bmatrix} 1 & 2 \\ 0 & 1 \\ 3 & 5 \\ -1 & -2 \end{bmatrix}.$$

- What are the domain and codomain of the composition map $S \circ T$?

³www.youtube.com/watch?v=WpUv72Y6Dl0

- A. The domain is \mathbb{R}^3 and the codomain is \mathbb{R}^2
- B. The domain is \mathbb{R}^2 and the codomain is \mathbb{R}^4
- C. The domain is \mathbb{R}^3 and the codomain is \mathbb{R}^4
- D. The domain is \mathbb{R}^4 and the codomain is \mathbb{R}^3

(b) What size will the standard matrix of $S \circ T$ be?

- A. 4 (rows) \times 3 (columns)
- B. 3 (rows) \times 4 (columns)
- C. 3 (rows) \times 2 (columns)
- D. 2 (rows) \times 4 (columns)

(c) Compute

$$(S \circ T)(\vec{e}_1) = S(T(\vec{e}_1)) = S\left(\begin{bmatrix} 2 \\ 5 \end{bmatrix}\right) = \begin{bmatrix} ? \\ ? \\ ? \\ ? \end{bmatrix}.$$

(d) Compute $(S \circ T)(\vec{e}_2)$.

(e) Compute $(S \circ T)(\vec{e}_3)$.

(f) Use $(S \circ T)(\vec{e}_1)$, $(S \circ T)(\vec{e}_2)$, $(S \circ T)(\vec{e}_3)$ to write the standard matrix for $S \circ T$.

Definition 4.1.4 We define the **product** AB of a $m \times n$ matrix A and a $n \times k$ matrix B to be the $m \times k$ standard matrix of the composition map of the two corresponding linear functions.

For the previous activity, T was a map $\mathbb{R}^3 \rightarrow \mathbb{R}^2$, and S was a map $\mathbb{R}^2 \rightarrow \mathbb{R}^4$, so $S \circ T$ gave a map $\mathbb{R}^3 \rightarrow \mathbb{R}^4$ with a 4×3 standard matrix:

$$AB = \begin{bmatrix} 1 & 2 \\ 0 & 1 \\ 3 & 5 \\ -1 & -2 \end{bmatrix} \begin{bmatrix} 2 & 1 & -3 \\ 5 & -3 & 4 \end{bmatrix}$$

$$= [(S \circ T)(\vec{e}_1) \quad (S \circ T)(\vec{e}_2) \quad (S \circ T)(\vec{e}_3)] = \begin{bmatrix} 12 & -5 & 5 \\ 5 & -3 & 4 \\ 31 & -12 & 11 \\ -12 & 5 & -5 \end{bmatrix}.$$

◇

Activity 4.1.5 Let $S : \mathbb{R}^3 \rightarrow \mathbb{R}^2$ be given by the matrix $A = \begin{bmatrix} -4 & -2 & 3 \\ 0 & 1 & 1 \end{bmatrix}$ and $T : \mathbb{R}^2 \rightarrow$

\mathbb{R}^3 be given by the matrix $B = \begin{bmatrix} 2 & 3 \\ 1 & -1 \\ 0 & -1 \end{bmatrix}$.

(a) Write the dimensions (rows \times columns) for A , B , AB , and BA .

(b) Find the standard matrix AB of $S \circ T$.

(c) Find the standard matrix BA of $T \circ S$.

Activity 4.1.6 Consider the following three matrices.

$$A = \begin{bmatrix} 1 & 0 & -3 \\ 3 & 2 & 1 \end{bmatrix} \quad B = \begin{bmatrix} 2 & 2 & 1 & 0 & 1 \\ 1 & 1 & 1 & -1 & 0 \\ 0 & 0 & 3 & 2 & 1 \\ -1 & 5 & 7 & 2 & 1 \end{bmatrix} \quad C = \begin{bmatrix} 2 & 2 \\ 0 & -1 \\ 3 & 1 \\ 4 & 0 \end{bmatrix}$$

(a) Find the domain and codomain of each of the three linear maps corresponding to A , B , and C .

(b) Only one of the matrix products AB, AC, BA, BC, CA, CB can actually be computed. Compute it.

Activity 4.1.7 Let $B = \begin{bmatrix} 3 & -4 & 0 \\ 2 & 0 & -1 \\ 0 & -3 & 3 \end{bmatrix}$, and let $A = \begin{bmatrix} 2 & 7 & -1 \\ 0 & 3 & 2 \\ 1 & 1 & -1 \end{bmatrix}$.

(a) Compute the product BA by hand.

(b) Check your work using technology. Using Octave:

```
B = [3 -4 0 ; 2 0 -1 ; 0 -3 3]
A = [2 7 -1 ; 0 3 2 ; 1 1 -1]
B*A
```

```
B = [3 -4 0 ; 2 0 -1 ; 0 -3 3]
A = [2 7 -1 ; 0 3 2 ; 1 1 -1]
B*A
```

Activity 4.1.8 Of the following three matrices, only two may be multiplied.

$$A = \begin{bmatrix} -1 & 3 & -2 & -3 \\ 1 & -4 & 2 & 3 \end{bmatrix} \quad B = \begin{bmatrix} 1 & -6 & -1 \\ 0 & 1 & 0 \end{bmatrix} \quad C = \begin{bmatrix} 1 & -1 & -1 \\ 0 & 1 & -2 \\ -2 & 4 & -1 \\ -2 & 3 & -1 \end{bmatrix}$$

Explain which two can be multiplied and why. Then show how to find their product.

Activity 4.1.9 Let $T\left(\begin{bmatrix} x \\ y \end{bmatrix}\right) = \begin{bmatrix} x + 2y \\ y \\ 3x + 5y \\ -x - 2y \end{bmatrix}$ In [Fact 3.2.11](#) we adopted the notation

$$T\left(\begin{bmatrix} x \\ y \end{bmatrix}\right) = \begin{bmatrix} x + 2y \\ y \\ 3x + 5y \\ -x - 2y \end{bmatrix} = A \begin{bmatrix} x \\ y \end{bmatrix} = \begin{bmatrix} 1 & 2 \\ 0 & 1 \\ 3 & 5 \\ -1 & -2 \end{bmatrix} \begin{bmatrix} x \\ y \end{bmatrix}.$$

Verify that $\begin{bmatrix} 1 & 2 \\ 0 & 1 \\ 3 & 5 \\ -1 & -2 \end{bmatrix} \begin{bmatrix} x \\ y \end{bmatrix} = \begin{bmatrix} x + 2y \\ y \\ 3x + 5y \\ -x - 2y \end{bmatrix}$ in terms of matrix multiplication.

4.1.3 Individual Practice

Activity 4.1.10 Given two $n \times n$ matrices A and B , explain why the sentence "Multiply the matrices A and B together." is ambiguous. How could you re-write the sentence in order to eliminate the ambiguity?

4.1.4 Videos

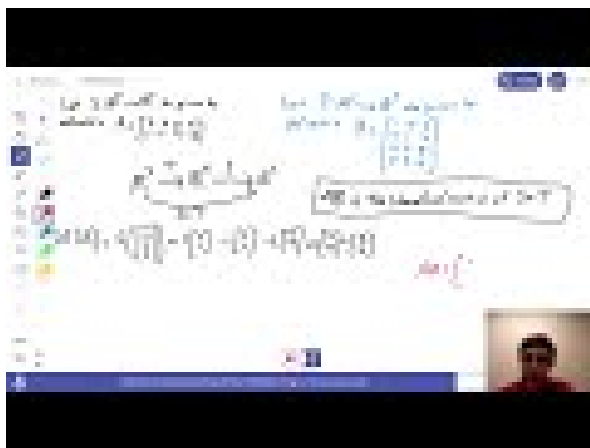

Figure 41 Video: Multiplying matrices



[Standalone](#)

4.1.5 Exercises

Exercises available at <https://tbil.org/linear-algebra/preview/exercises/#/bank/MX1/>.

4.1.6 Mathematical Writing Explorations

Exploration 4.1.11 Construct 3 matrices, A, B , and C , such that

- $AB : \mathbb{R}^4 \rightarrow \mathbb{R}^2$
- $BC : \mathbb{R}^2 \rightarrow \mathbb{R}^3$
- $CA : \mathbb{R}^3 \rightarrow \mathbb{R}^4$.
- $ABC : \mathbb{R}^2 \rightarrow \mathbb{R}^2$

Exploration 4.1.12 Construct 3 examples of matrix multiplication, with all matrix dimensions at least 2.

- Where A and B are not square, but AB is square.
- Where $AB = BA$.
- Where $AB \neq BA$.

Exploration 4.1.13 Use the included map in this problem.

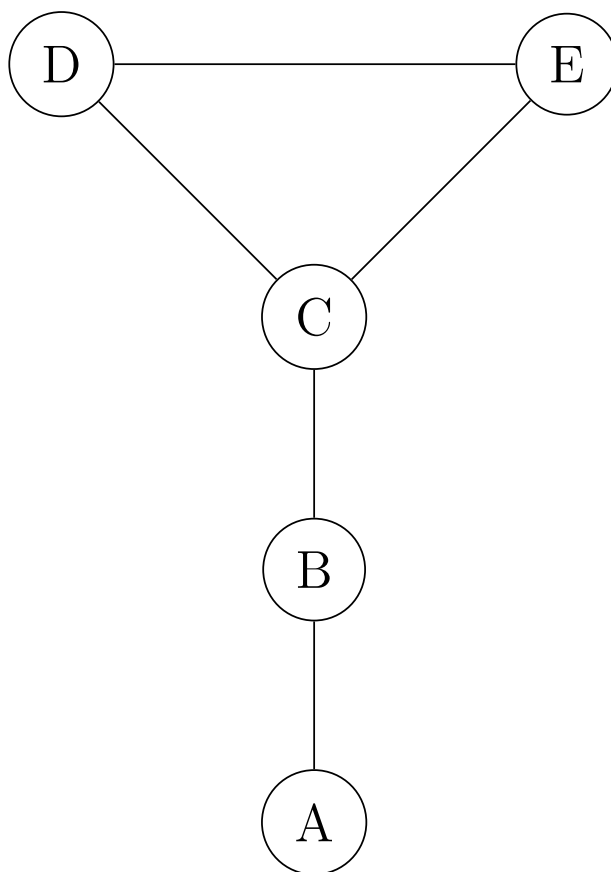

Figure 42 Adjacency map, showing roads between 5 cities

- An *adjacency matrix* for this map is a matrix that has the number of roads from

city i to city j in the (i, j) entry of the matrix. A road is a path of length exactly 1. All (i, i) entries are 0. Write the adjacency matrix for this map, with the cities in alphabetical order.

- What does the square of this matrix tell you about the map? The cube? The n -th power?

4.1.7 Sample Problem and Solution

Sample problem [Example B.1.18](#).

4.2 The Inverse of a Matrix (MX2)

Learning Outcomes

- Determine if a matrix is invertible, and if so, compute its inverse.

4.2.1 Warm Up

Activity 4.2.1 Consider the matrices:

$$A = \begin{bmatrix} 1 & 5 & -1 \\ 0 & 3 & 2 \end{bmatrix}, \quad B = \begin{bmatrix} 7 & 2 & -1 & 1 \\ 0 & 3 & 2 & -2 \\ 1 & 1 & -1 & -3 \end{bmatrix}.$$

Without using technology, what is the third column of the product AB ?

4.2.2 Class Activities

Activity 4.2.2 Let $A = \begin{bmatrix} 2 & 7 & -1 \\ 0 & 3 & 2 \\ 1 & 1 & -1 \end{bmatrix}$. Find a 3×3 matrix B such that $BA = A$, that is,

$$\begin{bmatrix} ? & ? & ? \\ ? & ? & ? \\ ? & ? & ? \end{bmatrix} \begin{bmatrix} 2 & 7 & -1 \\ 0 & 3 & 2 \\ 1 & 1 & -1 \end{bmatrix} = \begin{bmatrix} 2 & 7 & -1 \\ 0 & 3 & 2 \\ 1 & 1 & -1 \end{bmatrix}$$

Check your guess using technology.

Definition 4.2.3 The identity matrix I_n (or just I when n is obvious from context) is the $n \times n$ matrix

$$I_n = \begin{bmatrix} 1 & 0 & \cdots & 0 \\ 0 & 1 & \cdots & \vdots \\ \vdots & \cdots & \cdots & 0 \\ 0 & \cdots & 0 & 1 \end{bmatrix}.$$

It has a 1 on each diagonal element and a 0 in every other position. \diamond

Fact 4.2.4 For any square matrix A , $IA = AI = A$:

$$\begin{bmatrix} 1 & 0 & 0 \\ 0 & 1 & 0 \\ 0 & 0 & 1 \end{bmatrix} \begin{bmatrix} 2 & 7 & -1 \\ 0 & 3 & 2 \\ 1 & 1 & -1 \end{bmatrix} = \begin{bmatrix} 2 & 7 & -1 \\ 0 & 3 & 2 \\ 1 & 1 & -1 \end{bmatrix} \begin{bmatrix} 1 & 0 & 0 \\ 0 & 1 & 0 \\ 0 & 0 & 1 \end{bmatrix} = \begin{bmatrix} 2 & 7 & -1 \\ 0 & 3 & 2 \\ 1 & 1 & -1 \end{bmatrix}$$

Activity 4.2.5 Let $T : \mathbb{R}^n \rightarrow \mathbb{R}^m$ be a linear map with standard matrix A . Sort the following items into three groups of statements: a group that means T is *injective*, a group that means T is *surjective*, and a group that means T is *bijective*.

- A. $T(\vec{x}) = \vec{b}$ has a solution for all $\vec{b} \in \mathbb{R}^m$
- B. $T(\vec{x}) = \vec{b}$ has a unique solution for all $\vec{b} \in \mathbb{R}^m$
- C. $T(\vec{x}) = \vec{0}$ has a unique solution.
- D. The columns of A span \mathbb{R}^m
- E. The columns of A are linearly independent
- F. The columns of A are a basis of \mathbb{R}^m
- G. Every column of $\text{RREF}(A)$ has a pivot
- H. Every row of $\text{RREF}(A)$ has a pivot
- I. $m = n$ and $\text{RREF}(A) = I$

Definition 4.2.6 Let $T : \mathbb{R}^n \rightarrow \mathbb{R}^n$ be a linear bijection with standard matrix A .

By item (B) from [Activity 4.2.5](#) we may define an **inverse map** $T^{-1} : \mathbb{R}^n \rightarrow \mathbb{R}^n$ that defines $T^{-1}(\vec{b})$ as the unique solution \vec{x} satisfying $T(\vec{x}) = \vec{b}$, that is, $T(T^{-1}(\vec{b})) = \vec{b}$.

Furthermore, let

$$A^{-1} = [T^{-1}(\vec{e}_1) \quad \cdots \quad T^{-1}(\vec{e}_n)]$$

be the standard matrix for T^{-1} . We call A^{-1} the **inverse matrix** of A , and we also say that A is an **invertible** matrix. \diamond

Activity 4.2.7 Let $T : \mathbb{R}^3 \rightarrow \mathbb{R}^3$ be the linear bijection given by the standard matrix

$$A = \begin{bmatrix} 2 & -1 & -6 \\ 2 & 1 & 3 \\ 1 & 1 & 4 \end{bmatrix}.$$

- (a) To find $\vec{x} = T^{-1}(\vec{e}_1)$, we need to find the unique solution for $T(\vec{x}) = \vec{e}_1$. Which of these linear systems can be used to find this solution?

$$\begin{array}{l} 2x_1 - 1x_2 - 6x_3 = x_1 \\ \text{A. } 2x_1 + 1x_2 + 3x_3 = 0 \\ 1x_1 + 1x_2 + 4x_3 = 0 \end{array}$$

$$\begin{array}{l} 2x_1 - 1x_2 - 6x_3 = x_1 \\ \text{B. } 2x_1 + 1x_2 + 3x_3 = x_2 \\ 1x_1 + 1x_2 + 4x_3 = x_3 \end{array}$$

$$\begin{array}{l} 2x_1 - 1x_2 - 6x_3 = 1 \\ \text{C. } 2x_1 + 1x_2 + 3x_3 = 0 \\ 1x_1 + 1x_2 + 4x_3 = 0 \end{array}$$

$$\begin{array}{l} 2x_1 - 1x_2 - 6x_3 = 1 \\ \text{D. } 2x_1 + 1x_2 + 3x_3 = 1 \\ 1x_1 + 1x_2 + 4x_3 = 1 \end{array}$$

(b) Use that system to find the solution $\vec{x} = T^{-1}(\vec{e}_1)$ for $T(\vec{x}) = \vec{e}_1$.

(c) Similarly, solve $T(\vec{x}) = \vec{e}_2$ to find $T^{-1}(\vec{e}_2)$, and solve $T(\vec{x}) = \vec{e}_3$ to find $T^{-1}(\vec{e}_3)$.

(d) Use these to write

$$A^{-1} = [T^{-1}(\vec{e}_1) \quad T^{-1}(\vec{e}_2) \quad T^{-1}(\vec{e}_3)],$$

the standard matrix for T^{-1} .

Activity 4.2.8 Find the inverse A^{-1} of the matrix

$$A = \begin{bmatrix} 0 & 0 & 0 & -1 \\ 1 & 0 & -1 & -4 \\ 1 & 1 & 0 & -4 \\ 1 & -1 & -1 & 2 \end{bmatrix}$$

by computing how it transforms each of the standard basis vectors for \mathbb{R}^4 : $T^{-1}(\vec{e}_1)$, $T^{-1}(\vec{e}_2)$, $T^{-1}(\vec{e}_3)$, and $T^{-1}(\vec{e}_4)$.

Activity 4.2.9 Is the matrix $\begin{bmatrix} 2 & 3 & 1 \\ -1 & -4 & 2 \\ 0 & -5 & 5 \end{bmatrix}$ invertible?

A. Yes, because its transformation is a bijection.

B. Yes, because its transformation is not a bijection.

C. No, because its transformation is a bijection.

D. No, because its transformation is not a bijection.

Observation 4.2.10 An $n \times n$ matrix A is invertible if and only if $\text{RREF}(A) = I_n$.

Activity 4.2.11 Let $T : \mathbb{R}^2 \rightarrow \mathbb{R}^2$ be the bijective linear map defined by $T\left(\begin{bmatrix} x \\ y \end{bmatrix}\right) = \begin{bmatrix} 2x - 3y \\ -3x + 5y \end{bmatrix}$, with the inverse map $T^{-1}\left(\begin{bmatrix} x \\ y \end{bmatrix}\right) = \begin{bmatrix} 5x + 3y \\ 3x + 2y \end{bmatrix}$.

(a) Compute $(T^{-1} \circ T)\left(\begin{bmatrix} -2 \\ 1 \end{bmatrix}\right)$.

(b) If A is the standard matrix for T and A^{-1} is the standard matrix for T^{-1} , find the

2×2 matrix

$$A^{-1}A = \begin{bmatrix} ? & ? \\ ? & ? \end{bmatrix}.$$

Observation 4.2.12 $T^{-1} \circ T = T \circ T^{-1}$ is the identity map for any bijective linear transformation T . Therefore $A^{-1}A = AA^{-1}$ equals the identity matrix I for any invertible matrix A .

4.2.3 Individual Practice

Activity 4.2.13 Now that we have defined the inverse of a matrix, we have the ability to solve matrix equations. In the following equations, A, B all denote square matrices of the same size and I denotes the identity matrix. For each equation, solve for X .

(a) $A^{-1}XA = B$

(b) $AXA^{-1} = B$

(c) $ABX = I$

(d) $BAX = I$

4.2.4 Videos

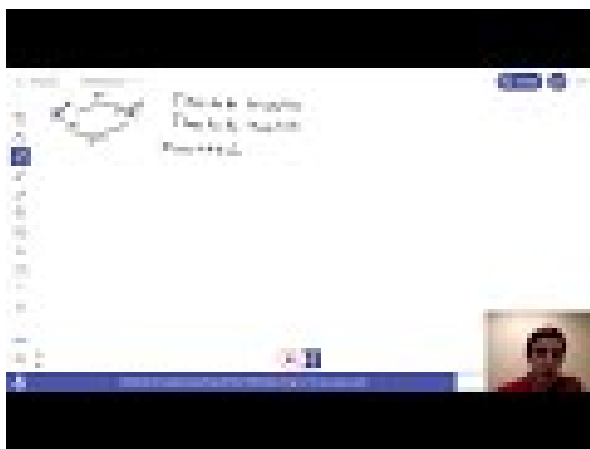

Standalone

Figure 43 Video: Invertible matrices

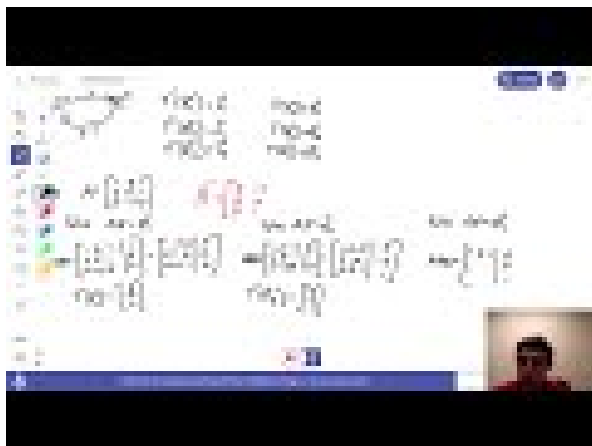

Standalone

Figure 44 Video: Finding the inverse of a matrix

4.2.5 Exercises

Exercises available at <https://tbil.org/linear-algebra/preview/exercises/#/bank/MX2/>.

4.2.6 Mathematical Writing Explorations

Exploration 4.2.14 Assume A is an $n \times n$ matrix. Prove the following are equivalent. Some of these results you have proven previously.

- A row reduces to the identity matrix.
- For any choice of $\vec{b} \in \mathbb{R}^n$, the system of equations represented by the augmented matrix $[A|\vec{b}]$ has a unique solution.
- The columns of A are a linearly independent set.
- The columns of A form a basis for \mathbb{R}^n .
- The rank of A is n .
- The nullity of A is 0.
- A is invertible.
- The linear transformation T with standard matrix A is injective and surjective. Such a map is called an *isomorphism*.

Exploration 4.2.15

- Assume T is a square matrix, and T^4 is the zero matrix. Prove that $(I - T)^{-1} = I + T + T^2 + T^3$. You will need to first prove a lemma that matrix multiplication distributes over matrix addition.
- Generalize your result to the case where T^n is the zero matrix.

4.2.7 Sample Problem and Solution

Sample problem [Example B.1.19](#).

4.3 Solving Systems with Matrix Inverses (MX3)

Learning Outcomes

- Invert an appropriate matrix to solve a system of linear equations.

4.3.1 Warm Up

Activity 4.3.1 Which of the following matrices is invertible? Find the inverse for the one that is invertible.

A. $\begin{bmatrix} 1 & -1 & 0 \\ -1 & 1 & 0 \\ 1 & 0 & 1 \end{bmatrix}$

B. $\begin{bmatrix} 1 & -1 & 3 \\ -1 & 1 & -1 \\ 1 & 0 & -2 \end{bmatrix}$

4.3.2 Class Activities

Activity 4.3.2 Consider the following linear system with a unique solution:

$$\begin{array}{rccccrcr} 3x_1 & - & 2x_2 & - & 2x_3 & - & 4x_4 & = & -7 \\ 2x_1 & - & x_2 & - & x_3 & - & x_4 & = & -1 \\ -x_1 & & & + & x_3 & & & = & -1 \\ & - & x_2 & & & - & 2x_4 & = & -5 \end{array}$$

(a) Suppose we let

$$T \left(\begin{bmatrix} x_1 \\ x_2 \\ x_3 \\ x_4 \end{bmatrix} \right) = \begin{bmatrix} 3x_1 & - & 2x_2 & - & 2x_3 & - & 4x_4 \\ 2x_1 & - & x_2 & - & x_3 & - & x_4 \\ -x_1 & & & + & x_3 & & \\ & - & x_2 & & & - & 2x_4 \end{bmatrix}.$$

Which of these choices would help us solve the given system?

A. Compute $T \left(\begin{bmatrix} -7 \\ -1 \\ -1 \\ -5 \end{bmatrix} \right)$

B. Find $\begin{bmatrix} x_1 \\ x_2 \\ x_3 \\ x_4 \end{bmatrix}$ where $T \left(\begin{bmatrix} x_1 \\ x_2 \\ x_3 \\ x_4 \end{bmatrix} \right) = \begin{bmatrix} -7 \\ -1 \\ -1 \\ -5 \end{bmatrix}$

(b) How can we express this in terms of matrix multiplication?

A. $\begin{bmatrix} 3 & -2 & -2 & -4 \\ 2 & -1 & -1 & -1 \\ -1 & 0 & 1 & 0 \\ 0 & -1 & 0 & -2 \end{bmatrix} \begin{bmatrix} x_1 \\ x_2 \\ x_3 \\ x_4 \end{bmatrix} = \begin{bmatrix} -7 \\ -1 \\ -1 \\ -5 \end{bmatrix}$

B. $\begin{bmatrix} x_1 \\ x_2 \\ x_3 \\ x_4 \end{bmatrix} = \begin{bmatrix} 3 & -2 & -2 & -4 \\ 2 & -1 & -1 & -1 \\ -1 & 0 & 1 & 0 \\ 0 & -1 & 0 & -2 \end{bmatrix} \begin{bmatrix} -7 \\ -1 \\ -1 \\ -5 \end{bmatrix}$

C. $\begin{bmatrix} x_1 \\ x_2 \\ x_3 \\ x_4 \end{bmatrix} \begin{bmatrix} 3 & -2 & -2 & -4 \\ 2 & -1 & -1 & -1 \\ -1 & 0 & 1 & 0 \\ 0 & -1 & 0 & -2 \end{bmatrix} = \begin{bmatrix} -7 \\ -1 \\ -1 \\ -5 \end{bmatrix}$

D. $\begin{bmatrix} x_1 \\ x_2 \\ x_3 \\ x_4 \end{bmatrix} = \begin{bmatrix} -7 \\ -1 \\ -1 \\ -5 \end{bmatrix} \begin{bmatrix} 3 & -2 & -2 & -4 \\ 2 & -1 & -1 & -1 \\ -1 & 0 & 1 & 0 \\ 0 & -1 & 0 & -2 \end{bmatrix}$

(c) How could a matrix equation of the form $A\vec{x} = \vec{b}$ be solved for \vec{x} ?

A. Multiply: $(\text{RREF } A)(A\vec{x}) = (\text{RREF } A)\vec{b}$

B. Add: $(\text{RREF } A) + A\vec{x} = (\text{RREF } A) + \vec{b}$

C. Multiply: $(A^{-1})(A\vec{x}) = (A^{-1})\vec{b}$

D. Add: $(A^{-1}) + A\vec{x} = (A^{-1}) + \vec{b}$

(d) Find $\begin{bmatrix} x_1 \\ x_2 \\ x_3 \\ x_4 \end{bmatrix}$ using the method you chose in (c).

Remark 4.3.3 The linear system described by the augmented matrix $[A \mid \vec{b}]$ has exactly the same solution set as the matrix equation $A\vec{x} = \vec{b}$.

When A is invertible, then we have both $[A \mid \vec{b}] \sim [I \mid \vec{x}]$ and $\vec{x} = A^{-1}\vec{b}$, which can be seen as

$$\begin{aligned} & A\vec{x} = \vec{b} \\ \Rightarrow & A^{-1}A\vec{x} = A^{-1}\vec{b} \end{aligned}$$

$$\Rightarrow \vec{x} = A^{-1}\vec{b}$$

Activity 4.3.4 Consider the vector equation

$$x_1 \begin{bmatrix} 1 \\ 2 \\ -2 \end{bmatrix} + x_2 \begin{bmatrix} -2 \\ -3 \\ 3 \end{bmatrix} + x_3 \begin{bmatrix} 1 \\ 4 \\ -3 \end{bmatrix} = \begin{bmatrix} -3 \\ 5 \\ -1 \end{bmatrix}$$

with a unique solution.

- Explain and demonstrate how this problem can be restated using matrix multiplication.
- Use the properties of matrix multiplication to find the unique solution.

4.3.3 Individual Practice

Activity 4.3.5 Solving linear systems using matrix multiplication is most useful when we are working with one common coefficient matrix, and varying the right-hand side. That is, when we have $A\vec{x} = \vec{b}$ for several different values of \vec{b} .

In the following, let $A = \begin{bmatrix} 2 & -1 & -6 \\ 2 & 1 & 3 \\ 1 & 1 & 4 \end{bmatrix}$ and consider the following questions about various equations of the form $A\vec{x} = \vec{b}$?

- Suppose that $\vec{b} = \begin{bmatrix} 1 \\ 1 \\ 1 \end{bmatrix}$. If asked to solve the equation $A\vec{x} = \vec{b}$, which of the following approaches do you prefer?
 - Calculate $\text{RREF}[A|\vec{b}]$.
 - Calculate A^{-1} and then compute $\vec{x} = A^{-1}\vec{b}$
- Suppose that $\vec{b}_1, \vec{b}_2, \vec{b}_3 = \begin{bmatrix} 1 \\ 1 \\ 1 \end{bmatrix}, \begin{bmatrix} 2 \\ 1 \\ 3 \end{bmatrix}, \begin{bmatrix} -1 \\ 3 \\ 5 \end{bmatrix}$. If asked to solve each of the equations $A\vec{x} = \vec{b}_1, A\vec{x} = \vec{b}_2, A\vec{x} = \vec{b}_3$, which of the following approaches do you prefer?
 - Calculate $\text{RREF}[A|\vec{b}_1], \text{RREF}[A|\vec{b}_2],$ and $\text{RREF}[A|\vec{b}_3]$
 - Calculate A^{-1} and then compute $\vec{x} = A^{-1}\vec{b}_1, \vec{x} = A^{-1}\vec{b}_2,$ and $\vec{x} = A^{-1}\vec{b}_3$
- Suppose that $\vec{b}_1, \dots, \vec{b}_{10}$ are 10 distinct vectors. If asked to solve each of the equations $A\vec{x} = \vec{b}_1, \dots, A\vec{x} = \vec{b}_{10}$, which of the following approaches do you prefer?
 - Calculate $\text{RREF}[A|\vec{b}_1], \dots \text{RREF}[A|\vec{b}_{10}]$.
 - Calculate A^{-1} and then compute $\vec{x} = A^{-1}\vec{b}_1, \dots \vec{x} = A^{-1}\vec{b}_{10}$.

4.3.4 Videos

Video coming soon to [this YouTube playlist](#)¹.

4.3.5 Exercises

Exercises available at <https://tbil.org/linear-algebra/preview/exercises/#/bank/MX3/>.

4.3.6 Mathematical Writing Explorations

Exploration 4.3.6 Use row reduction to find the inverse of the following general matrix. Give conditions on which this inverse exists.

$$\begin{bmatrix} 1 & b & c \\ d & e & f \\ g & h & i \end{bmatrix}$$

Exploration 4.3.7 Assume that H is invertible, and that HG is the zero matrix. Prove that G must be the zero matrix. Would this still be true if H were not invertible?

Exploration 4.3.8 If H is invertible and $r \in \mathbb{R}$, what is the inverse of rH ?

Exploration 4.3.9 If H and G are invertible, is $H^{-1} + G^{-1} = (H + G)^{-1}$?

Exploration 4.3.10 Prove that if A , P , and Q are invertible with $PAQ = I$, then $A^{-1} = QP$.

4.3.7 Sample Problem and Solution

Sample problem [Example B.1.20](#).

4.4 Row Operations as Matrix Multiplication (MX4)

Learning Outcomes

- Express row operations through matrix multiplication.

4.4.1 Warm Up

Activity 4.4.1 Given a linear transformation T , how did we define its standard matrix A ? How do we compute the standard matrix A from T ?

¹www.youtube.com/watch?v=kpOK7RhFEiQ&list=PLwXCBkIf7xBMo3zMnD7WVt39rANLlSdmj

4.4.2 Class Activities

Activity 4.4.2 Tweaking the identity matrix slightly allows us to write row operations in terms of matrix multiplication.

- (a) Which of these tweaks of the identity matrix yields a matrix that doubles the third row of A when left-multiplying? ($2R_3 \rightarrow R_3$)

$$\begin{bmatrix} ? & ? & ? \\ ? & ? & ? \\ ? & ? & ? \end{bmatrix} \begin{bmatrix} 2 & 7 & -1 \\ 0 & 3 & 2 \\ 1 & 1 & -1 \end{bmatrix} = \begin{bmatrix} 2 & 7 & -1 \\ 0 & 3 & 2 \\ 2 & 2 & -2 \end{bmatrix}$$

A. $\begin{bmatrix} 2 & 0 & 0 \\ 0 & 1 & 0 \\ 0 & 0 & 1 \end{bmatrix}$

C. $\begin{bmatrix} 1 & 0 & 0 \\ 0 & 1 & 0 \\ 0 & 0 & 2 \end{bmatrix}$

B. $\begin{bmatrix} 1 & 0 & 0 \\ 0 & 2 & 0 \\ 0 & 0 & 1 \end{bmatrix}$

D. $\begin{bmatrix} 2 & 0 & 0 \\ 0 & 2 & 0 \\ 0 & 0 & 2 \end{bmatrix}$

- (b) Which of these tweaks of the identity matrix yields a matrix that swaps the first and third rows of A when left-multiplying? ($R_1 \leftrightarrow R_3$)

$$\begin{bmatrix} ? & ? & ? \\ ? & ? & ? \\ ? & ? & ? \end{bmatrix} \begin{bmatrix} 2 & 7 & -1 \\ 0 & 3 & 2 \\ 1 & 1 & -1 \end{bmatrix} = \begin{bmatrix} 2 & 7 & -1 \\ 1 & 1 & -1 \\ 0 & 3 & 2 \end{bmatrix}$$

A. $\begin{bmatrix} 1 & 0 & 0 \\ 0 & 0 & 1 \\ 0 & 1 & 0 \end{bmatrix}$

C. $\begin{bmatrix} 0 & 0 & 1 \\ 0 & 1 & 0 \\ 1 & 0 & 0 \end{bmatrix}$

B. $\begin{bmatrix} 0 & 1 & 0 \\ 0 & 0 & 1 \\ 1 & 0 & 0 \end{bmatrix}$

D. $\begin{bmatrix} 0 & 1 & 0 \\ 1 & 0 & 0 \\ 0 & 0 & 1 \end{bmatrix}$

- (c) Which of these tweaks of the identity matrix yields a matrix that adds 5 times the third row of A to the first row when left-multiplying? ($R_1 + 5R_3 \rightarrow R_1$)

$$\begin{bmatrix} ? & ? & ? \\ ? & ? & ? \\ ? & ? & ? \end{bmatrix} \begin{bmatrix} 2 & 7 & -1 \\ 0 & 3 & 2 \\ 1 & 1 & -1 \end{bmatrix} = \begin{bmatrix} 2 + 5(1) & 7 + 5(1) & -1 + 5(-1) \\ 0 & 3 & 2 \\ 1 & 1 & -1 \end{bmatrix}$$

A. $\begin{bmatrix} 1 & 0 & 1 \\ 0 & 1 & 0 \\ 0 & 0 & 5 \end{bmatrix}$

C. $\begin{bmatrix} 5 & 5 & 5 \\ 0 & 1 & 0 \\ 0 & 0 & 1 \end{bmatrix}$

B. $\begin{bmatrix} 1 & 0 & 5 \\ 0 & 1 & 0 \\ 0 & 0 & 1 \end{bmatrix}$

D. $\begin{bmatrix} 1 & 0 & 5 \\ 0 & 1 & 0 \\ 0 & 0 & 5 \end{bmatrix}$

Fact 4.4.3 If R is the result of applying a row operation to I , then RA is the result of applying the same row operation to A .

- Scaling a row: $R = \begin{bmatrix} c & 0 & 0 \\ 0 & 1 & 0 \\ 0 & 0 & 1 \end{bmatrix}$

- Swapping rows: $R = \begin{bmatrix} 0 & 1 & 0 \\ 1 & 0 & 0 \\ 0 & 0 & 1 \end{bmatrix}$

- Adding a row multiple to another row: $R = \begin{bmatrix} 1 & 0 & c \\ 0 & 1 & 0 \\ 0 & 0 & 1 \end{bmatrix}$

Such matrices can be chained together to emulate multiple row operations. In particular,

$$\text{RREF}(A) = R_k \dots R_2 R_1 A$$

for some sequence of matrices R_1, R_2, \dots, R_k .

Activity 4.4.4 What would happen if you *right*-multiplied by the tweaked identity matrix rather than left-multiplied?

- The manipulated rows would be reversed.
- Columns would be manipulated instead of rows.
- The entries of the resulting matrix would be rotated 180 degrees.

Activity 4.4.5 Consider the two row operations $R_2 \leftrightarrow R_3$ and $R_1 + R_2 \rightarrow R_1$ applied as follows to show $A \sim B$:

$$\begin{aligned} A = \begin{bmatrix} -1 & 4 & 5 \\ 0 & 3 & -1 \\ 1 & 2 & 3 \end{bmatrix} &\sim \begin{bmatrix} -1 & 4 & 5 \\ 1 & 2 & 3 \\ 0 & 3 & -1 \end{bmatrix} \\ &\sim \begin{bmatrix} -1+1 & 4+2 & 5+3 \\ 1 & 2 & 3 \\ 0 & 3 & -1 \end{bmatrix} = \begin{bmatrix} 0 & 6 & 8 \\ 1 & 2 & 3 \\ 0 & 3 & -1 \end{bmatrix} = B \end{aligned}$$

Express these row operations as matrix multiplication by expressing B as the product of two matrices and A :

$$B = \begin{bmatrix} ? & ? & ? \\ ? & ? & ? \\ ? & ? & ? \end{bmatrix} \begin{bmatrix} ? & ? & ? \\ ? & ? & ? \\ ? & ? & ? \end{bmatrix} A$$

Check your work using technology.

Activity 4.4.6 Let A be *any* 4×4 matrix.

- Give a 4×4 matrix M that may be used to perform the row operation $-5R_2 \rightarrow R_2$.

- (b) Give a 4×4 matrix Y that may be used to perform the row operation $R_2 \leftrightarrow R_3$.
- (c) Use matrix multiplication to describe the matrix obtained by applying $-5R_2 \rightarrow R_2$ and then $R_2 \leftrightarrow R_3$ to A (note the order).

4.4.3 Individual Practice

Activity 4.4.7 Consider the matrix $A = \begin{bmatrix} 2 & 6 & -1 & 6 \\ 1 & 3 & -1 & 2 \\ -1 & -3 & 2 & 0 \end{bmatrix}$. Illustrate [Fact 4.4.3](#) by finding row operation matrices R_1, \dots, R_k for which

$$\text{RREF}(A) = R_k \cdots R_2 R_1 A.$$

If you and a teammate were to do this independently, would you necessarily come up with the same sequence of matrices R_1, \dots, R_k ?

4.4.4 Videos

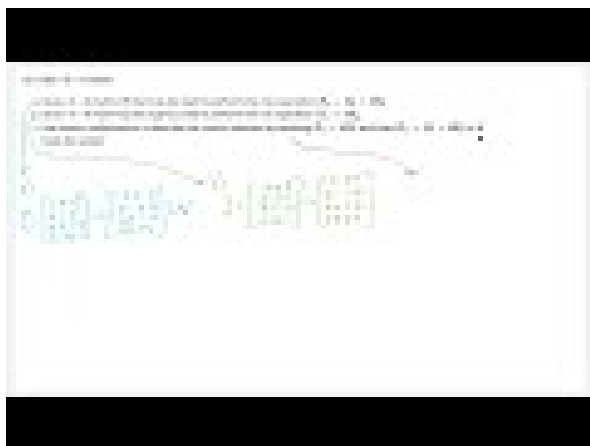

[Standalone](#)

Figure 45 Video: Row operations as matrix multiplication

4.4.5 Exercises

Exercises available at <https://tbil.org/linear-algebra/preview/exercises/#/bank/MX4/>.

4.4.6 Sample Problem and Solution

Sample problem [Example B.1.21](#).

Chapter 5

Geometric Properties of Linear Maps (GT)

Learning Outcomes

How do we understand linear maps geometrically?
By the end of this chapter, you should be able to...

1. Describe how a row operation affects the determinant of a matrix.
2. Compute the determinant of a 4×4 matrix.
3. Find the eigenvalues of a 2×2 matrix.
4. Find a basis for the eigenspace of a 4×4 matrix associated with a given eigenvalue.

Readiness Assurance. Before beginning this chapter, you should be able to...

1. Calculate the area of a parallelogram.
 - Review: [Khan Academy](#)¹
2. Recall and use the definition of a linear transformation.
 - Review: [Section 3.1](#)
3. Find the matrix corresponding to a linear transformation of Euclidean spaces.
 - Review: [Section 3.2](#)
4. Find all roots of quadratic polynomials (including complex ones).

¹www.khanacademy.org/math/cc-sixth-grade-math/cc-6th-geometry-topic/cc-6th-parallelogram-area/v/intuition-for-area-of-a-parallelogram

- Review: [Khan Academy](#)², [YouTube \(1\)](#)³, [YouTube \(2\)](#)⁴
5. Interpret the statement “ A is an invertible matrix” in many equivalent ways in different contexts.
- Review: [Section 4.3](#)

5.1 Row Operations and Determinants (GT1)

Learning Outcomes

- Describe how a row operation affects the determinant of a matrix.

5.1.1 Warm Up

Activity 5.1.1 Consider the linear transformation $T: \mathbb{R}^2 \rightarrow \mathbb{R}^2$ corresponding to the standard matrix $A = \begin{bmatrix} 1 & 3 \\ -1 & 2 \end{bmatrix}$.

- (a) Draw a figure that depicts how T transforms the unit square.
- (b) What geometric features of the unit square were preserved by the transformation? Which geometric features changed?

5.1.2 Class Activities

Activity 5.1.2 The image in [Figure 46](#) illustrates how the linear transformation $T: \mathbb{R}^2 \rightarrow \mathbb{R}^2$ given by the standard matrix $A = \begin{bmatrix} 2 & 0 \\ 0 & 3 \end{bmatrix}$ transforms the unit square.

²www.khanacademy.org/math/algebra-home/alg-polynomials/alg-factoring-polynomials-quadratic-forms/v/factoring-trinomials-by-grouping-5

³youtu.be/Aa-v1EK7DR4

⁴www.youtube.com/watch?v=2yBhDsNE0w

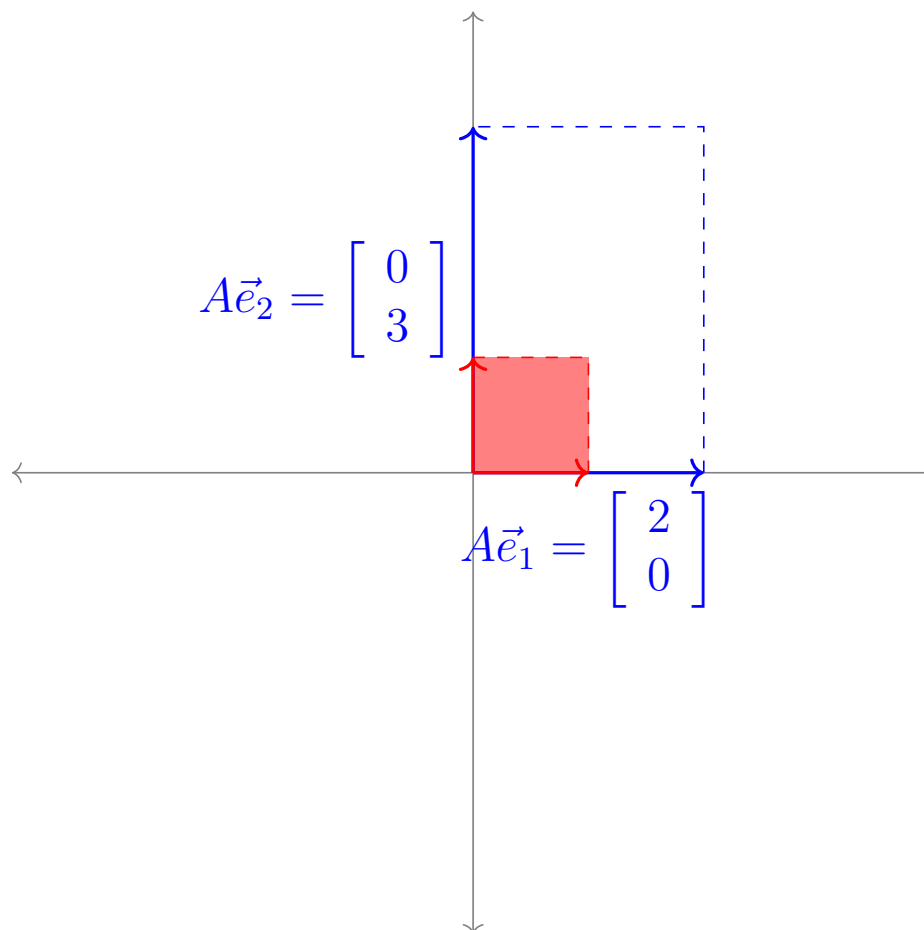

Figure 46 Transformation of the unit square by the matrix A .

- (a) What are the lengths of $A\vec{e}_1$ and $A\vec{e}_2$?
- (b) What is the area of the transformed unit square?

Activity 5.1.3 The image below illustrates how the linear transformation $S : \mathbb{R}^2 \rightarrow \mathbb{R}^2$ given by the standard matrix $B = \begin{bmatrix} 2 & 3 \\ 0 & 4 \end{bmatrix}$ transforms the unit square.

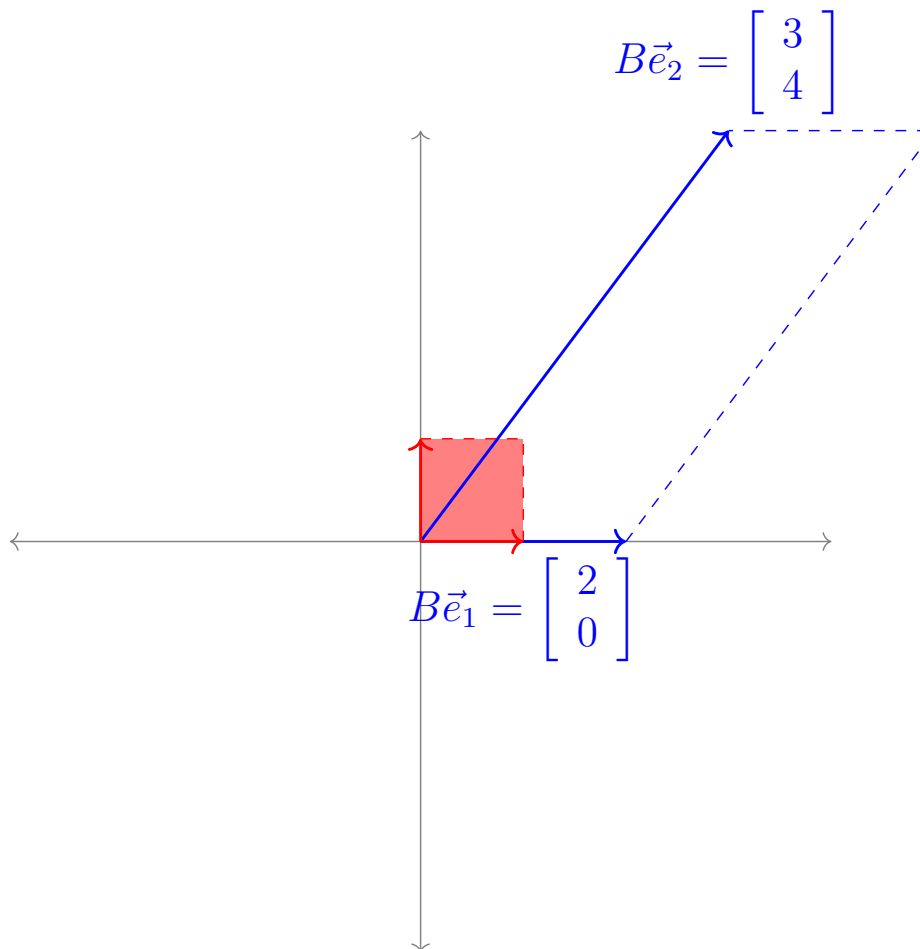

Figure 47 Transformation of the unit square by the matrix B

- (a) What are the lengths of $B\vec{e}_1$ and $B\vec{e}_2$?
- (b) What is the area of the transformed unit square?

Observation 5.1.4 It is possible to find two nonparallel vectors that are scaled but not rotated by the linear map given by B .

$$B\vec{e}_1 = \begin{bmatrix} 2 & 3 \\ 0 & 4 \end{bmatrix} \begin{bmatrix} 1 \\ 0 \end{bmatrix} = \begin{bmatrix} 2 \\ 0 \end{bmatrix} = 2\vec{e}_1$$

$$B \begin{bmatrix} \frac{3}{4} \\ \frac{1}{2} \end{bmatrix} = \begin{bmatrix} 2 & 3 \\ 0 & 4 \end{bmatrix} \begin{bmatrix} \frac{3}{4} \\ \frac{1}{2} \end{bmatrix} = \begin{bmatrix} 3 \\ 2 \end{bmatrix} = 4 \begin{bmatrix} \frac{3}{4} \\ \frac{1}{2} \end{bmatrix}$$

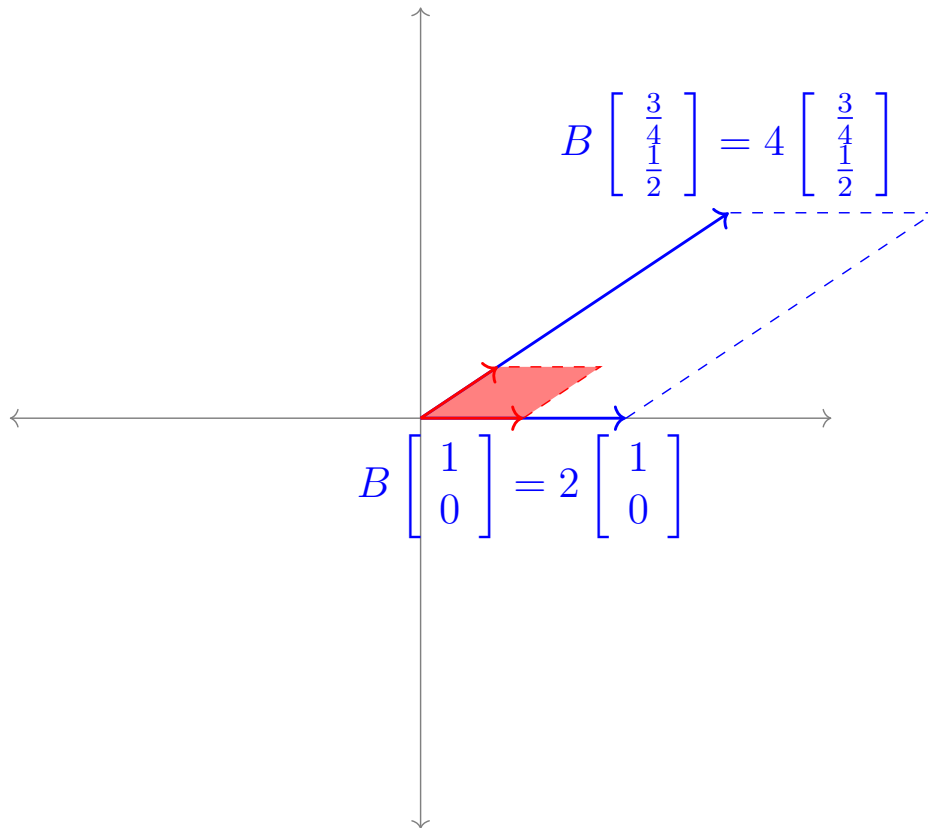

Figure 48 Certain vectors are stretched out without being rotated.

The process for finding such vectors will be covered later in this chapter.

Observation 5.1.5 Notice that while a linear map can transform vectors in various ways, linear maps always transform parallelograms into parallelograms, and these areas are always transformed by the same factor: in the case of $B = \begin{bmatrix} 2 & 3 \\ 0 & 4 \end{bmatrix}$, this factor is 8.

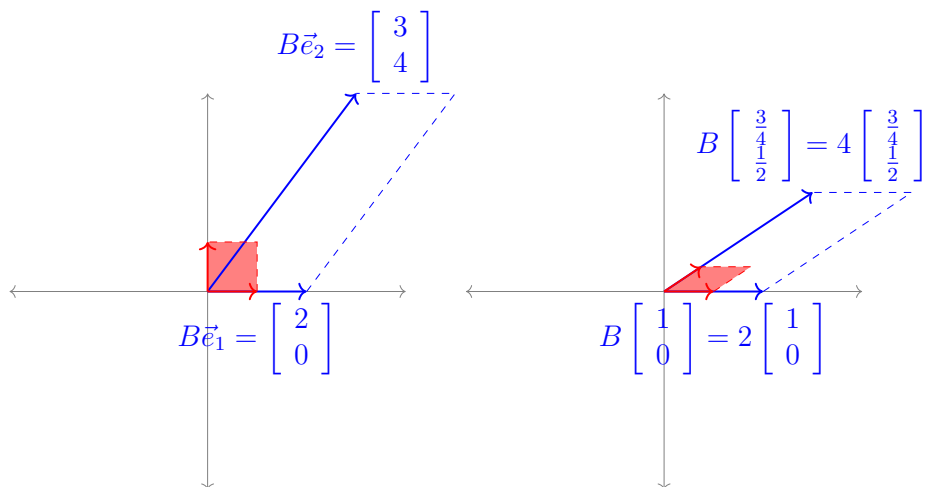

Figure 49 A linear map transforming parallelograms into parallelograms.

Since this change in area is always the same for a given linear map, it will be equal to

the value of the transformed unit square (which begins with area 1).

Remark 5.1.6 We will define the **determinant** of a square matrix B , or $\det(B)$ for short, to be the factor by which B scales areas. In order to figure out how to compute it, we first figure out the properties it must satisfy.

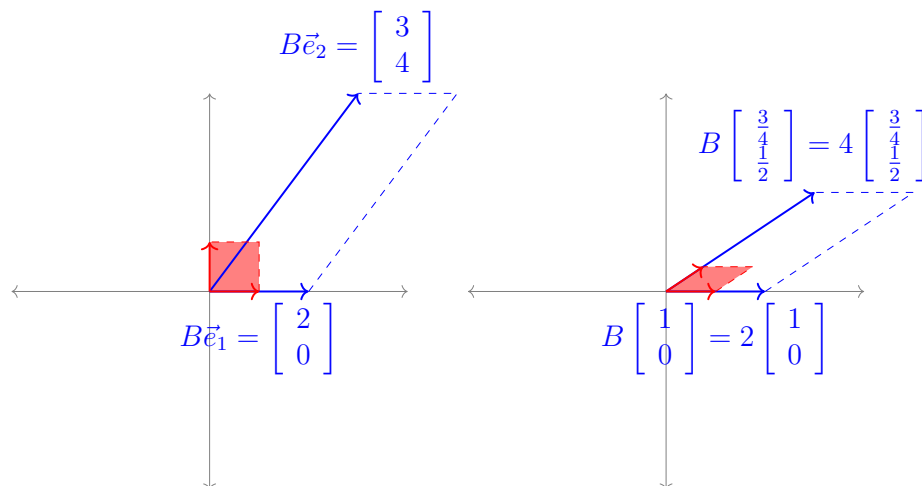

Figure 50 The linear transformation B scaling areas by a constant factor, which we call the **determinant**

Activity 5.1.7 The transformation of the unit square by the standard matrix $[\vec{e}_1 \ \vec{e}_2] = \begin{bmatrix} 1 & 0 \\ 0 & 1 \end{bmatrix} = I$ is illustrated below. If $\det([\vec{e}_1 \ \vec{e}_2]) = \det(I)$ is the area of resulting parallelogram, what is the value of $\det([\vec{e}_1 \ \vec{e}_2]) = \det(I)$?

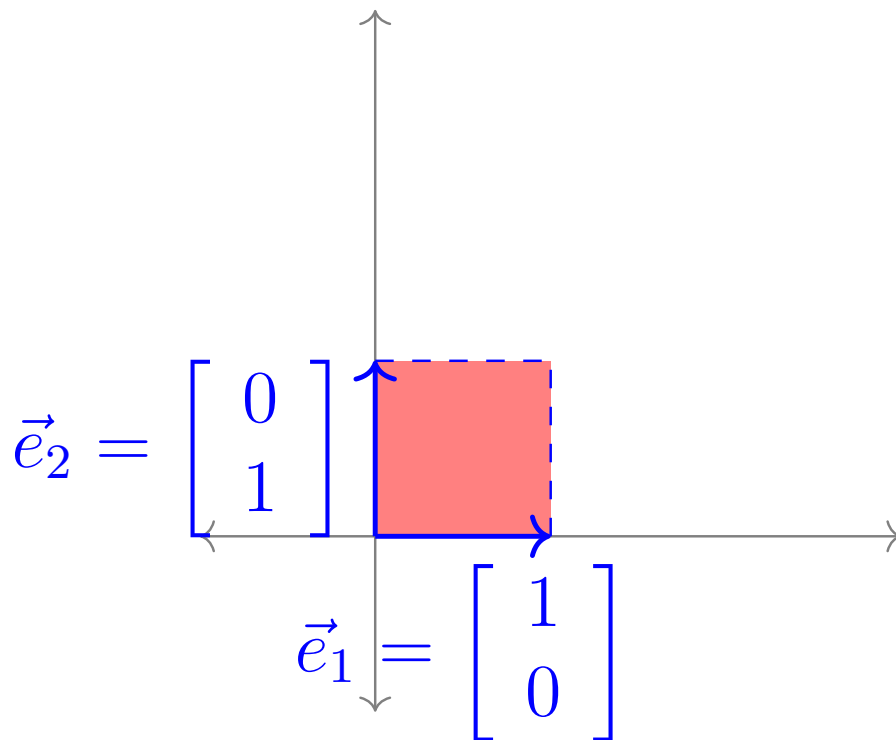

Figure 51 The transformation of the unit square by the identity matrix.

The value for $\det([\vec{e}_1 \ \vec{e}_2]) = \det(I)$ is:

- | | |
|------|------|
| A. 0 | C. 2 |
| B. 1 | D. 4 |

Activity 5.1.8 The transformation of the unit square by the standard matrix $[\vec{v} \ \vec{v}]$ is illustrated below: both $T(\vec{e}_1) = T(\vec{e}_2) = \vec{v}$. If $\det([\vec{v} \ \vec{v}])$ is the area of the generated parallelogram, what is the value of $\det([\vec{v} \ \vec{v}])$?

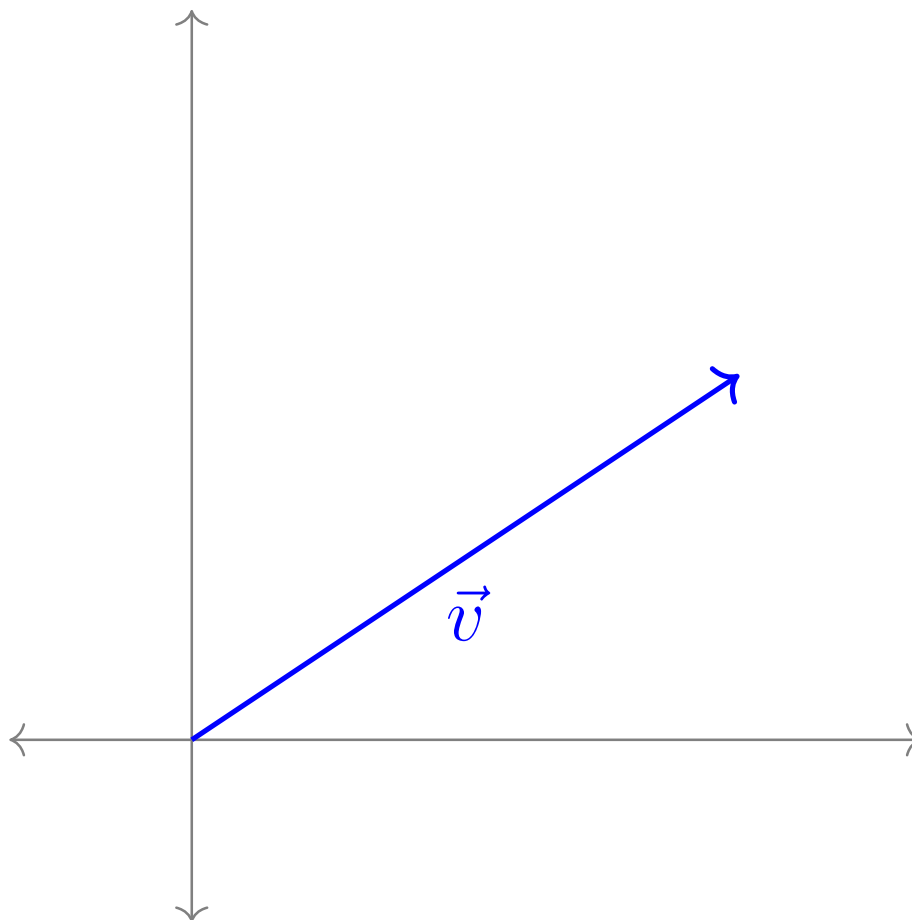

Figure 52 Transformation of the unit square by a matrix with identical columns.

The value of $\det([\vec{v} \ \vec{v}])$ is:

- A. 0
- B. 1
- C. 2
- D. 4

Activity 5.1.9

Adjust the vectors \vec{v} , $c\vec{v}$, and \vec{w} in the left graph to visualize the area calculated by $\det[\vec{v} \ \vec{w}]$ in comparison to $\det[c\vec{v} \ \vec{w}]$.

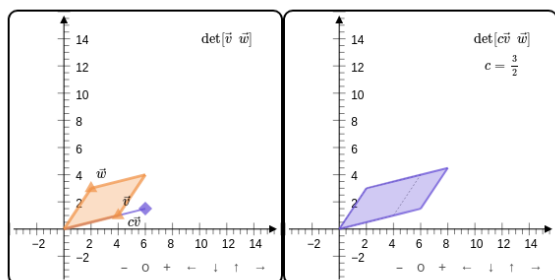

Standalone
Embed

Describe the value of $\det([c\vec{v} \ \vec{w}])$:

A. $\det([\vec{v} \ \vec{w}])$

C. $c^2 \det([\vec{v} \ \vec{w}])$

B. $c \det([\vec{v} \ \vec{w}])$

D. Cannot be determined from this information.

Activity 5.1.10

Adjust the vectors \vec{u} , \vec{v} , and \vec{w} in the left graph to visualize the areas calculated by $\det[\vec{u} \ \vec{w}]$, $\det[\vec{v} \ \vec{w}]$, and $\det[\vec{u} + \vec{v} \ \vec{w}]$.

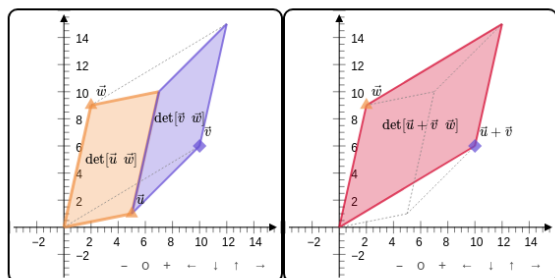

[Standalone](#)
[Embed](#)

Describe the value of $\det([\vec{u} + \vec{v} \ \vec{w}])$.

A. $\det([\vec{u} \ \vec{w}]) = \det([\vec{v} \ \vec{w}])$

C. $\det([\vec{u} \ \vec{w}]) \det([\vec{v} \ \vec{w}])$

B. $\det([\vec{u} \ \vec{w}]) + \det([\vec{v} \ \vec{w}])$

D. Cannot be determined from this information.

Definition 5.1.11 The **determinant** is the unique function $\det : M_{n,n} \rightarrow \mathbb{R}$ satisfying these properties:

1. $\det(I) = 1$
2. $\det(A) = 0$ whenever two columns of the matrix are identical.
3. $\det[\cdots \ c\vec{v} \ \cdots] = c \det[\cdots \ \vec{v} \ \cdots]$, assuming no other columns change.
4. $\det[\cdots \ \vec{v} + \vec{w} \ \cdots] = \det[\cdots \ \vec{v} \ \cdots] + \det[\cdots \ \vec{w} \ \cdots]$, assuming no other columns change.

Note that these last two properties together can be phrased as “The determinant is linear in each column.” ◇

Observation 5.1.12 The determinant must also satisfy other properties. Consider $\det([\vec{v} \ \vec{w} + c\vec{v}])$ and $\det([\vec{v} \ \vec{w}])$.

Adjust the vectors \vec{v} and \vec{w} and $\vec{w} + c\vec{v}$ in the left graph to visualize the areas calculated by $\det[\vec{v} \ \vec{w}]$ and $\det[\vec{v} \ \vec{w} + c\vec{v}]$.

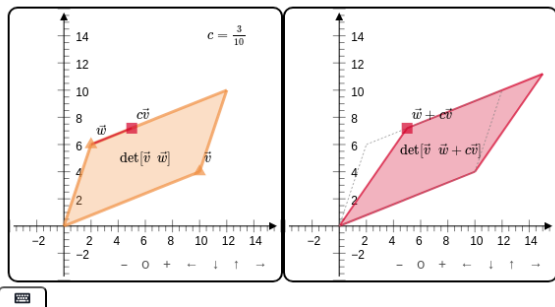

[Standalone](#)
[Embed](#)

The base of both parallelograms is \vec{v} , while the height has not changed, so the determinant does not change either. This can also be proven using the other properties of the determinant:

$$\begin{aligned} \det([\vec{v} + c\vec{w} \ \vec{w}]) &= \det([\vec{v} \ \vec{w}]) + \det([c\vec{w} \ \vec{w}]) \\ &= \det([\vec{v} \ \vec{w}]) + c \det([\vec{w} \ \vec{w}]) \\ &= \det([\vec{v} \ \vec{w}]) + c \cdot 0 \\ &= \det([\vec{v} \ \vec{w}]) \end{aligned}$$

Remark 5.1.13 Swapping columns may be thought of as a reflection, which is represented by a negative determinant. For example, the following matrices transform the unit square into the same parallelogram, but the second matrix reflects its orientation.

$$A = \begin{bmatrix} 2 & 3 \\ 0 & 4 \end{bmatrix} \quad \det A = 8 \quad B = \begin{bmatrix} 3 & 2 \\ 4 & 0 \end{bmatrix} \quad \det B = -8$$

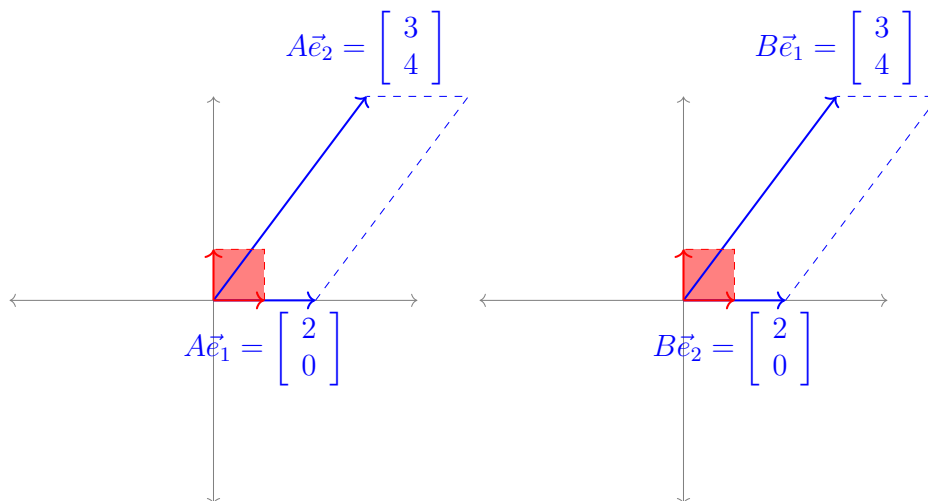

Figure 53 Reflection of a parallelogram as a result of swapping columns.

Observation 5.1.14 The fact that swapping columns multiplies determinants by a negative may be verified by adding and subtracting columns.

$$\det([\vec{v} \ \vec{w}]) = \det([\vec{v} + \vec{w} \ \vec{w}])$$

$$\begin{aligned}
&= \det([\vec{v} + \vec{w} \quad \vec{w} - (\vec{v} + \vec{w})]) \\
&= \det([\vec{v} + \vec{w} \quad -\vec{v}]) \\
&= \det([\vec{v} + \vec{w} - \vec{v} \quad -\vec{v}]) \\
&= \det([\vec{w} \quad -\vec{v}]) \\
&= -\det([\vec{w} \quad \vec{v}])
\end{aligned}$$

Fact 5.1.15 To summarize, we've shown that the column versions of the three row-reducing operations a matrix may be used to simplify a determinant in the following way:

1. Multiplying a column by a scalar multiplies the determinant by that scalar:

$$c \det([\dots \vec{v} \dots]) = \det([\dots c\vec{v} \dots])$$

2. Swapping two columns changes the sign of the determinant:

$$\det([\dots \vec{v} \dots \vec{w} \dots]) = -\det([\dots \vec{w} \dots \vec{v} \dots])$$

3. Adding a multiple of a column to another column does not change the determinant:

$$\det([\dots \vec{v} \dots \vec{w} \dots]) = \det([\dots \vec{v} + c\vec{w} \dots \vec{w} \dots])$$

Activity 5.1.16 The transformation given by the standard matrix A scales areas by 4, and the transformation given by the standard matrix B scales areas by 3. By what factor does the transformation given by the standard matrix AB scale areas?

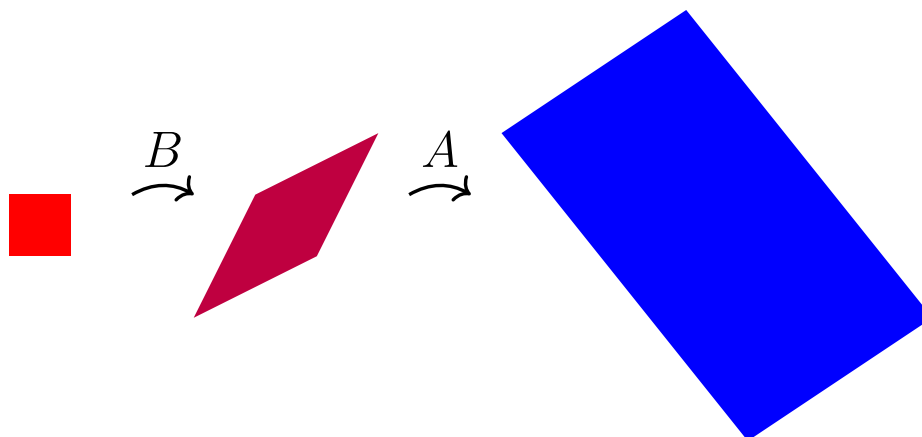

Figure 54 Area changing under the composition of two linear maps

- | | |
|------|-------------------------|
| A. 1 | C. 12 |
| B. 7 | D. Cannot be determined |

Fact 5.1.17 Since the transformation given by the standard matrix AB is obtained by applying the transformations given by A and B , it follows that

$$\det(AB) = \det(A) \det(B) = \det(B) \det(A) = \det(BA).$$

Remark 5.1.18 Recall that row operations may be produced by matrix multiplication.

- Multiply the first row of A by c : $\begin{bmatrix} c & 0 & 0 & 0 \\ 0 & 1 & 0 & 0 \\ 0 & 0 & 1 & 0 \\ 0 & 0 & 0 & 1 \end{bmatrix} A$
- Swap the first and second row of A : $\begin{bmatrix} 0 & 1 & 0 & 0 \\ 1 & 0 & 0 & 0 \\ 0 & 0 & 1 & 0 \\ 0 & 0 & 0 & 1 \end{bmatrix} A$
- Add c times the third row to the first row of A : $\begin{bmatrix} 1 & 0 & c & 0 \\ 0 & 1 & 0 & 0 \\ 0 & 0 & 1 & 0 \\ 0 & 0 & 0 & 1 \end{bmatrix} A$

Fact 5.1.19 The determinants of row operation matrices may be computed by manipulating columns to reduce each matrix to the identity:

- Scaling a row: $\det \begin{bmatrix} c & 0 & 0 & 0 \\ 0 & 1 & 0 & 0 \\ 0 & 0 & 1 & 0 \\ 0 & 0 & 0 & 1 \end{bmatrix} = c \det \begin{bmatrix} 1 & 0 & 0 & 0 \\ 0 & 1 & 0 & 0 \\ 0 & 0 & 1 & 0 \\ 0 & 0 & 0 & 1 \end{bmatrix} = c$
- Swapping rows: $\det \begin{bmatrix} 0 & 1 & 0 & 0 \\ 1 & 0 & 0 & 0 \\ 0 & 0 & 1 & 0 \\ 0 & 0 & 0 & 1 \end{bmatrix} = -1 \det \begin{bmatrix} 1 & 0 & 0 & 0 \\ 0 & 1 & 0 & 0 \\ 0 & 0 & 1 & 0 \\ 0 & 0 & 0 & 1 \end{bmatrix} = -1$
- Adding a row multiple to another row: $\det \begin{bmatrix} 1 & 0 & c & 0 \\ 0 & 1 & 0 & 0 \\ 0 & 0 & 1 & 0 \\ 0 & 0 & 0 & 1 \end{bmatrix} =$
 $\det \begin{bmatrix} 1 & 0 & c-1c & 0 \\ 0 & 1 & 0-0c & 0 \\ 0 & 0 & 1-0c & 0 \\ 0 & 0 & 0-0c & 1 \end{bmatrix} = \det(I) = 1$

Activity 5.1.20 Consider the row operation $R_1 + 4R_3 \rightarrow R_1$ applied as follows to show $A \sim B$:

$$A = \begin{bmatrix} 1 & 2 & 3 & 4 \\ 5 & 6 & 7 & 8 \\ 9 & 10 & 11 & 12 \\ 13 & 14 & 15 & 16 \end{bmatrix} \sim \begin{bmatrix} 1+4(9) & 2+4(10) & 3+4(11) & 4+4(12) \\ 5 & 6 & 7 & 8 \\ 9 & 10 & 11 & 12 \\ 13 & 14 & 15 & 16 \end{bmatrix} = B$$

(a) Find a matrix R such that $B = RA$, by applying the same row operation to $I =$

$$\begin{bmatrix} 1 & 0 & 0 & 0 \\ 0 & 1 & 0 & 0 \\ 0 & 0 & 1 & 0 \\ 0 & 0 & 0 & 1 \end{bmatrix}.$$

(b) Find $\det R$ by comparing with the previous slide.

(c) If $C \in M_{4,4}$ is a matrix with $\det(C) = -3$, find

$$\det(RC) = \det(R) \det(C).$$

Activity 5.1.21 Consider the row operation $R_1 \leftrightarrow R_3$ applied as follows to show $A \sim B$:

$$A = \begin{bmatrix} 1 & 2 & 3 & 4 \\ 5 & 6 & 7 & 8 \\ 9 & 10 & 11 & 12 \\ 13 & 14 & 15 & 16 \end{bmatrix} \sim \begin{bmatrix} 9 & 10 & 11 & 12 \\ 5 & 6 & 7 & 8 \\ 1 & 2 & 3 & 4 \\ 13 & 14 & 15 & 16 \end{bmatrix} = B$$

(a) Find a matrix R such that $B = RA$, by applying the same row operation to I .

(b) If $C \in M_{4,4}$ is a matrix with $\det(C) = 5$, find $\det(RC)$.

Activity 5.1.22 Consider the row operation $3R_2 \rightarrow R_2$ applied as follows to show $A \sim B$:

$$A = \begin{bmatrix} 1 & 2 & 3 & 4 \\ 5 & 6 & 7 & 8 \\ 9 & 10 & 11 & 12 \\ 13 & 14 & 15 & 16 \end{bmatrix} \sim \begin{bmatrix} 1 & 2 & 3 & 4 \\ 3(5) & 3(6) & 3(7) & 3(8) \\ 9 & 10 & 11 & 12 \\ 13 & 14 & 15 & 16 \end{bmatrix} = B$$

(a) Find a matrix R such that $B = RA$.

(b) If $C \in M_{4,4}$ is a matrix with $\det(C) = -7$, find $\det(RC)$.

Activity 5.1.23 Let A be *any* 4×4 matrix with determinant 2.

(a) Let B be the matrix obtained from A by applying the row operation $R_1 - 5R_3 \rightarrow R_1$. What is $\det B$?

A -4

B -2

C 2

D 10

(b) Let M be the matrix obtained from A by applying the row operation $R_3 \leftrightarrow R_1$. What is $\det M$?

A -4

B -2

C 2

D 10

(c) Let P be the matrix obtained from A by applying the row operation $2R_4 \rightarrow R_4$. What is $\det P$?

A -4

B -2

C 2

D 10

Remark 5.1.24 Recall that the column versions of the three row-reducing operations a matrix may be used to simplify a determinant:

1. Multiplying columns by scalars:

$$\det([\cdots \ c\vec{v} \ \cdots]) = c \det([\cdots \ \vec{v} \ \cdots])$$

2. Swapping two columns:

$$\det([\cdots \ \vec{v} \ \cdots \ \vec{w} \ \cdots]) = -\det([\cdots \ \vec{w} \ \cdots \ \vec{v} \ \cdots])$$

3. Adding a multiple of a column to another column:

$$\det([\cdots \ \vec{v} \ \cdots \ \vec{w} \ \cdots]) = \det([\cdots \ \vec{v} + c\vec{w} \ \cdots \ \vec{w} \ \cdots])$$

Remark 5.1.25 The determinants of row operation matrices may be computed by manipulating columns to reduce each matrix to the identity:

- Scaling a row:
$$\begin{bmatrix} 1 & 0 & 0 & 0 \\ 0 & c & 0 & 0 \\ 0 & 0 & 1 & 0 \\ 0 & 0 & 0 & 0 \end{bmatrix}$$

- Swapping rows:
$$\begin{bmatrix} 0 & 1 & 0 & 0 \\ 1 & 0 & 0 & 0 \\ 0 & 0 & 1 & 0 \\ 0 & 0 & 0 & 0 \end{bmatrix}$$

- Adding a row multiple to another row:
$$\begin{bmatrix} 1 & 0 & 0 & 0 \\ 0 & 1 & c & 0 \\ 0 & 0 & 1 & 0 \\ 0 & 0 & 0 & 1 \end{bmatrix}$$

Fact 5.1.26 Thus we can also use both row operations to simplify determinants:

- Multiplying rows by scalars:

$$\det \begin{bmatrix} \vdots \\ cR \\ \vdots \end{bmatrix} = c \det \begin{bmatrix} \vdots \\ R \\ \vdots \end{bmatrix}$$

- Swapping two rows:

$$\det \begin{bmatrix} \vdots \\ R \\ \vdots \\ S \\ \vdots \end{bmatrix} = -\det \begin{bmatrix} \vdots \\ S \\ \vdots \\ R \\ \vdots \end{bmatrix}$$

- Adding multiples of rows/columns to other rows:

$$\det \begin{bmatrix} \vdots \\ R \\ \vdots \\ S \\ \vdots \end{bmatrix} = \det \begin{bmatrix} \vdots \\ R + cS \\ \vdots \\ S \\ \vdots \end{bmatrix}$$

Activity 5.1.27 Complete the following derivation for a formula calculating 2×2 determinants:

$$\begin{aligned} \det \begin{bmatrix} a & b \\ c & d \end{bmatrix} &= ? \det \begin{bmatrix} 1 & b/a \\ c & d \end{bmatrix} \\ &= ? \det \begin{bmatrix} 1 & b/a \\ c - c & d - bc/a \end{bmatrix} \\ &= ? \det \begin{bmatrix} 1 & b/a \\ 0 & d - bc/a \end{bmatrix} \\ &= ? \det \begin{bmatrix} 1 & b/a \\ 0 & 1 \end{bmatrix} \\ &= ? \det \begin{bmatrix} 1 & 0 \\ 0 & 1 \end{bmatrix} \\ &= ? \det I \\ &= ? \end{aligned}$$

Observation 5.1.28 So we may compute the determinant of $\begin{bmatrix} 2 & 4 \\ 2 & 3 \end{bmatrix}$ by using determinant properties to manipulate its rows/columns to reduce the matrix to I :

$$\begin{aligned} \det \begin{bmatrix} 2 & 4 \\ 2 & 3 \end{bmatrix} &= 2 \det \begin{bmatrix} 1 & 2 \\ 2 & 3 \end{bmatrix} \\ &= 2 \det \begin{bmatrix} 1 & 2 \\ 0 & -1 \end{bmatrix} \\ &= -2 \det \begin{bmatrix} 1 & -2 \\ 0 & 1 \end{bmatrix} \\ &= -2 \det \begin{bmatrix} 1 & 0 \\ 0 & 1 \end{bmatrix} \\ &= -2 \end{aligned}$$

Or we may use a formula:

$$\det \begin{bmatrix} 2 & 4 \\ 2 & 3 \end{bmatrix} = (2)(3) - (4)(2) = -2$$

5.1.3 Individual Practice

Activity 5.1.29 Suppose we have a linear transformation $T: \mathbb{R}^2 \rightarrow \mathbb{R}^2$. Given some shape S in the plane \mathbb{R}^2 , we can use T to transform it into some new shape $T(S)$. Consider the following questions about properties that may or may not be preserved by T .

- If S is a straight line segment, explain why $T(S)$ is also a straight line segment.
- If S is a straight line segment, does $T(S)$ necessarily have to have the same length as that of S ?
- If S is a triangle, explain why $T(S)$ is also a triangle.
- Continuing as above, do the angles of $T(S)$ necessarily have to be the same as those of S ?

5.1.4 Videos

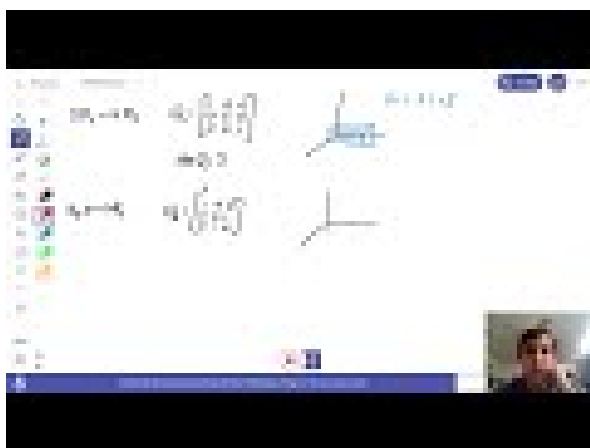

Standalone

Figure 55 Video: Row operations, matrix multiplication, and determinants

5.1.5 Exercises

Exercises available at <https://tbil.org/linear-algebra/preview/exercises/#/bank/GT1/>.

5.1.6 Mathematical Writing Explorations

Exploration 5.1.30

- Prove or disprove. The determinant is a linear operator on the vector space of $n \times n$ matrices.
- Find a matrix that will double the area of a region in \mathbb{R}^2 .
- Find a matrix that will triple the area of a region in \mathbb{R}^2 .
- Find a matrix that will halve the area of a region in \mathbb{R}^2 .

5.1.7 Sample Problem and Solution

Sample problem [Example B.1.22](#).

5.2 Computing Determinants (GT2)

Learning Outcomes

- Compute the determinant of a 4×4 matrix.

5.2.1 Warm Up

Activity 5.2.1 Consider the matrix $A = \begin{bmatrix} 1 & 2 \\ 3 & 4 \end{bmatrix}$.

- Use a combination of row and column operations to transform A into the identity matrix. Use this to calculate the determinant of A .
- Check your work using the formula for the determinant of a 2×2 matrix.

5.2.2 Class Activities

Remark 5.2.2 We've seen that row reducing all the way into RREF gives us a method of computing determinants.

However, we learned in [Chapter 1](#) that this can be tedious for large matrices. Thus, we will try to figure out how to turn the determinant of a larger matrix into the determinant of a smaller matrix.

Activity 5.2.3 The following image illustrates the transformation of the unit cube by the

matrix $\begin{bmatrix} 1 & 1 & 0 \\ 1 & 3 & 1 \\ 0 & 0 & 1 \end{bmatrix}$.

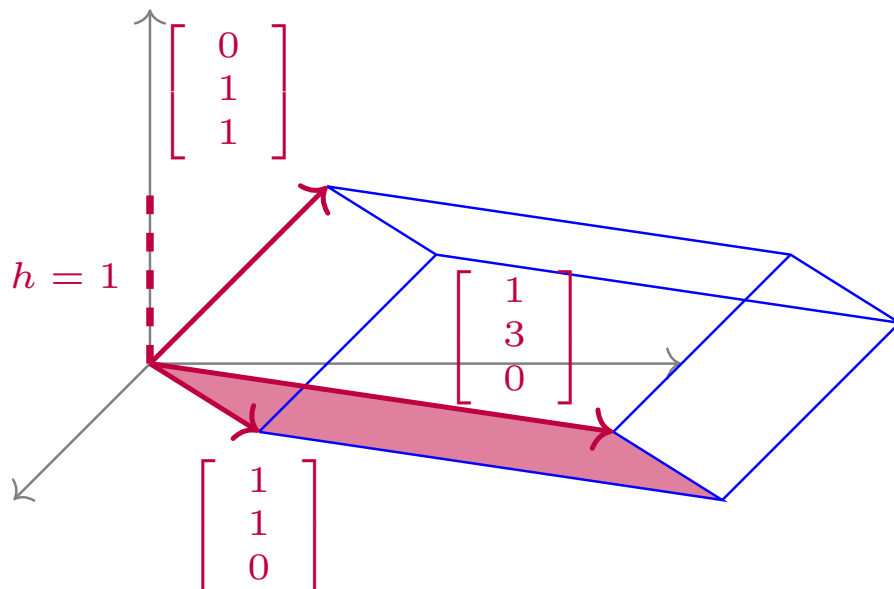

Figure 56 Transformation of the unit cube by the linear transformation.

Recall that for this solid $V = Bh$, where h is the height of the solid and B is the area of its parallelogram base. So what must its volume be?

A. $\det \begin{bmatrix} 1 & 1 \\ 1 & 3 \end{bmatrix}$

C. $\det \begin{bmatrix} 1 & 1 \\ 0 & 1 \end{bmatrix}$

B. $\det \begin{bmatrix} 1 & 0 \\ 3 & 1 \end{bmatrix}$

D. $\det \begin{bmatrix} 1 & 3 \\ 0 & 0 \end{bmatrix}$

Fact 5.2.4 If row i contains all zeros except for a 1 on the main (upper-left to lower-right) diagonal, then both column and row i may be removed without changing the value of the determinant.

$$\det \begin{bmatrix} 3 & 2 & -1 & 3 \\ 0 & 1 & 0 & 0 \\ -1 & 4 & 1 & 0 \\ 5 & 0 & 11 & 1 \end{bmatrix} = \det \begin{bmatrix} 3 & -1 & 3 \\ -1 & 1 & 0 \\ 5 & 11 & 1 \end{bmatrix}$$

Since row and column operations affect the determinants in the same way, the same technique works for a column of all zeros except for a 1 on the main diagonal.

$$\det \begin{bmatrix} 3 & 0 & -1 & 5 \\ 2 & 1 & 4 & 0 \\ -1 & 0 & 1 & 11 \\ 3 & 0 & 0 & 1 \end{bmatrix} = \det \begin{bmatrix} 3 & -1 & 5 \\ -1 & 1 & 11 \\ 3 & 0 & 1 \end{bmatrix}$$

Put another way, if you have either a column or row from the identity matrix, you can cancel both the column and row containing the 1.

Warning 5.2.5 If the 1 is not on the main diagonal, you'll need to use row or column swaps

in order to cancel.

$$\det \begin{bmatrix} 3 & 0 & -1 & 5 \\ -1 & 0 & 1 & 11 \\ 2 & 1 & 4 & 0 \\ 3 & 0 & 0 & 1 \end{bmatrix} = -\det \begin{bmatrix} 3 & 0 & -1 & 5 \\ 2 & 1 & 4 & 0 \\ -1 & 0 & 1 & 11 \\ 3 & 0 & 0 & 1 \end{bmatrix} = -\det \begin{bmatrix} 3 & -1 & 5 \\ -1 & 1 & 11 \\ 3 & 0 & 1 \end{bmatrix}$$

Activity 5.2.6 Remove an appropriate row and column of $\det \begin{bmatrix} 1 & 0 & 0 \\ 1 & 5 & 12 \\ 3 & 2 & -1 \end{bmatrix}$ to simplify the determinant to a 2×2 determinant.

Activity 5.2.7 Simplify $\det \begin{bmatrix} 0 & 3 & -2 \\ 2 & 5 & 12 \\ 0 & 2 & -1 \end{bmatrix}$ to a multiple of a 2×2 determinant by first doing the following:

- (a) Factor out a 2 from a column.
- (b) Swap rows or columns to put a 1 on the main diagonal.

Activity 5.2.8 Simplify $\det \begin{bmatrix} 4 & -2 & 2 \\ 3 & 1 & 4 \\ 1 & -1 & 3 \end{bmatrix}$ to a multiple of a 2×2 determinant by first doing the following:

- (a) Use row/column operations to create two zeroes in the same row or column.
- (b) Factor/swap as needed to get a row/column of all zeroes except a 1 on the main diagonal.

Observation 5.2.9 Using row/column operations, you can introduce zeros and reduce dimension to whittle down the determinant of a large matrix to a determinant of a smaller matrix.

$$\begin{aligned} \det \begin{bmatrix} 4 & 3 & 0 & 1 \\ 2 & -2 & 4 & 0 \\ -1 & 4 & 1 & 5 \\ 2 & 8 & 0 & 3 \end{bmatrix} &= \det \begin{bmatrix} 4 & 3 & 0 & 1 \\ 6 & -18 & 0 & -20 \\ -1 & 4 & 1 & 5 \\ 2 & 8 & 0 & 3 \end{bmatrix} = \det \begin{bmatrix} 4 & 3 & 1 \\ 6 & -18 & -20 \\ 2 & 8 & 3 \end{bmatrix} \\ &= \dots = -2 \det \begin{bmatrix} 1 & 3 & 4 \\ 0 & 21 & 43 \\ 0 & -1 & -10 \end{bmatrix} = -2 \det \begin{bmatrix} 21 & 43 \\ -1 & -10 \end{bmatrix} \\ &= \dots = -2 \det \begin{bmatrix} -167 & 21 \\ 0 & 1 \end{bmatrix} = -2 \det[-167] \\ &= -2(-167) \det(I) = 334 \end{aligned}$$

Activity 5.2.10 Rewrite

$$\det \begin{bmatrix} 2 & 1 & -2 & 1 \\ 3 & 0 & 1 & 4 \\ -2 & 2 & 3 & 0 \\ -2 & 0 & -3 & -3 \end{bmatrix}$$

as a multiple of a determinant of a 3×3 matrix.

Activity 5.2.11 Compute $\det \begin{bmatrix} 2 & 3 & 5 & 0 \\ 0 & 3 & 2 & 0 \\ 1 & 2 & 0 & 3 \\ -1 & -1 & 2 & 2 \end{bmatrix}$ by using any combination of row/column

operations.

Observation 5.2.12 Another option is to take advantage of the fact that the determinant is linear in each row or column. This approach is called **Laplace expansion** or **cofactor expansion**.

For example, since $\begin{bmatrix} 1 & 2 & 4 \end{bmatrix} = 1 \begin{bmatrix} 1 & 0 & 0 \end{bmatrix} + 2 \begin{bmatrix} 0 & 1 & 0 \end{bmatrix} + 4 \begin{bmatrix} 0 & 0 & 1 \end{bmatrix}$,

$$\begin{aligned} \det \begin{bmatrix} 2 & 3 & 5 \\ -1 & 3 & 5 \\ 1 & 2 & 4 \end{bmatrix} &= 1 \det \begin{bmatrix} 2 & 3 & 5 \\ -1 & 3 & 5 \\ 1 & 0 & 0 \end{bmatrix} + 2 \det \begin{bmatrix} 2 & 3 & 5 \\ -1 & 3 & 5 \\ 0 & 1 & 0 \end{bmatrix} + 4 \det \begin{bmatrix} 2 & 3 & 5 \\ -1 & 3 & 5 \\ 0 & 0 & 1 \end{bmatrix} \\ &= -1 \det \begin{bmatrix} 5 & 3 & 2 \\ 5 & 3 & -1 \\ 0 & 0 & 1 \end{bmatrix} - 2 \det \begin{bmatrix} 2 & 5 & 3 \\ -1 & 5 & 3 \\ 0 & 0 & 1 \end{bmatrix} + 4 \det \begin{bmatrix} 2 & 3 & 5 \\ -1 & 3 & 5 \\ 0 & 0 & 1 \end{bmatrix} \\ &= -\det \begin{bmatrix} 5 & 3 \\ 5 & 3 \end{bmatrix} - 2 \det \begin{bmatrix} 2 & 5 \\ -1 & 5 \end{bmatrix} + 4 \det \begin{bmatrix} 2 & 3 \\ -1 & 3 \end{bmatrix} \end{aligned}$$

Observation 5.2.13 Recall the formula for a 2×2 determinant found in [Observation 5.1.28](#):

$$\det \begin{bmatrix} a & b \\ c & d \end{bmatrix} = ad - bc.$$

There are formulas and algorithms for the determinants of larger matrices, but they can be pretty tedious to use. For example, writing out a formula for a 4×4 determinant would require 24 different terms!

$$\det \begin{bmatrix} a_{11} & a_{12} & a_{13} & a_{14} \\ a_{21} & a_{22} & a_{23} & a_{24} \\ a_{31} & a_{32} & a_{33} & a_{34} \\ a_{41} & a_{42} & a_{43} & a_{44} \end{bmatrix} = a_{11}(a_{22}(a_{33}a_{44} - a_{43}a_{34}) - a_{23}(a_{32}a_{44} - a_{42}a_{34}) + \dots) + \dots$$

Activity 5.2.14 Based on the previous activities, which technique is easier for computing determinants?

- A. Memorizing formulas.
- B. Using row/column operations.

C. Laplace expansion.

D. Some other technique.

Activity 5.2.15 Use your preferred technique to compute $\det \begin{bmatrix} 4 & -3 & 0 & 0 \\ 1 & -3 & 2 & -1 \\ 3 & 2 & 0 & 3 \\ 0 & -3 & 2 & -2 \end{bmatrix}$.

Insight 5.2.16 You can check your answers using technology.

```
det([4, -3, 0, 0; 1, -3, 2, -1; 3, 2, 0, 3; 0, -3, 2, -2])
```

5.2.3 Individual Practice

Activity 5.2.17 A *diagonal* matrix is a matrix that has zeroes in every position except (possibly) the main upper-left to lower-right diagonal. A matrix is *upper* (resp. *lower*) *triangular* if every entry below (resp. above) the main diagonal is zero.

- Explain why the determinant of a diagonal matrix is always equal to the product of the entries on the main diagonal.
- Explain why the determinant of an upper (or lower) triangular matrix is always equal to the product of the entries on the main diagonal.

5.2.4 Videos



Standalone

Figure 57 Video: Simplifying a determinant using row operations

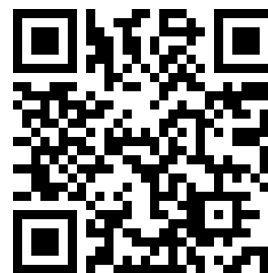

Standalone

Figure 58 Video: Computing a determinant

5.2.5 Exercises

Exercises available at <https://tbil.org/linear-algebra/preview/exercises/#/bank/GT2/>.

5.2.6 Mathematical Writing Explorations

Exploration 5.2.18 Prove that the equation of a line in the plane, through points $(x_1, y_1), (x_2, y_2)$, when $x_1 \neq x_2$ is given by the equation $\det \begin{pmatrix} x & y & 1 \\ x_1 & y_1 & 1 \\ x_2 & y_2 & 1 \end{pmatrix} = 0$.

Exploration 5.2.19 Show that, if an $n \times n$ matrix M has a non-zero determinant, then any $\vec{v} \in \mathbb{R}^n$ can be represented as a linear combination of the columns of M .

Exploration 5.2.20 What is the smallest number of zeros necessary to place in a 4×4 matrix, and the placement of those zeros, such that the matrix has a zero determinant?

5.2.7 Sample Problem and Solution

Sample problem [Example B.1.23](#).

5.3 Eigenvalues and Characteristic Polynomials (GT3)

Learning Outcomes

- Find the eigenvalues of a 2×2 matrix.

5.3.1 Warm Up

Activity 5.3.1 Let $R: \mathbb{R}^2 \rightarrow \mathbb{R}^2$ be the transformation given by rotating vectors about the origin through an angle of 45° , and let $S: \mathbb{R}^2 \rightarrow \mathbb{R}^2$ denote the transformation that reflects vectors about the line $x_1 = x_2$.

- (a) If L is a line, let $R(L)$ denote the line obtained by applying R to it. Are there any lines L for which $R(L)$ is parallel to L ?
- (b) Now consider the transformation S . Are there any lines L for which $S(L)$ is parallel to L ?

5.3.2 Class Activities

Activity 5.3.2 An invertible matrix M and its inverse M^{-1} are given below:

$$M = \begin{bmatrix} 1 & 2 \\ 3 & 4 \end{bmatrix} \quad M^{-1} = \begin{bmatrix} -2 & 1 \\ 3/2 & -1/2 \end{bmatrix}$$

Which of the following is equal to $\det(M) \det(M^{-1})$?

- | | |
|---------|--------|
| A. -1 | C. 1 |
| B. 0 | D. 4 |

Fact 5.3.3 For every invertible matrix M ,

$$\det(M) \det(M^{-1}) = \det(I) = 1$$

so $\det(M^{-1}) = \frac{1}{\det(M)}$.

Furthermore, a square matrix M is invertible if and only if $\det(M) \neq 0$.

Observation 5.3.4 Consider the linear transformation $A: \mathbb{R}^2 \rightarrow \mathbb{R}^2$ given by the matrix

$$A = \begin{bmatrix} 2 & 2 \\ 0 & 3 \end{bmatrix}.$$

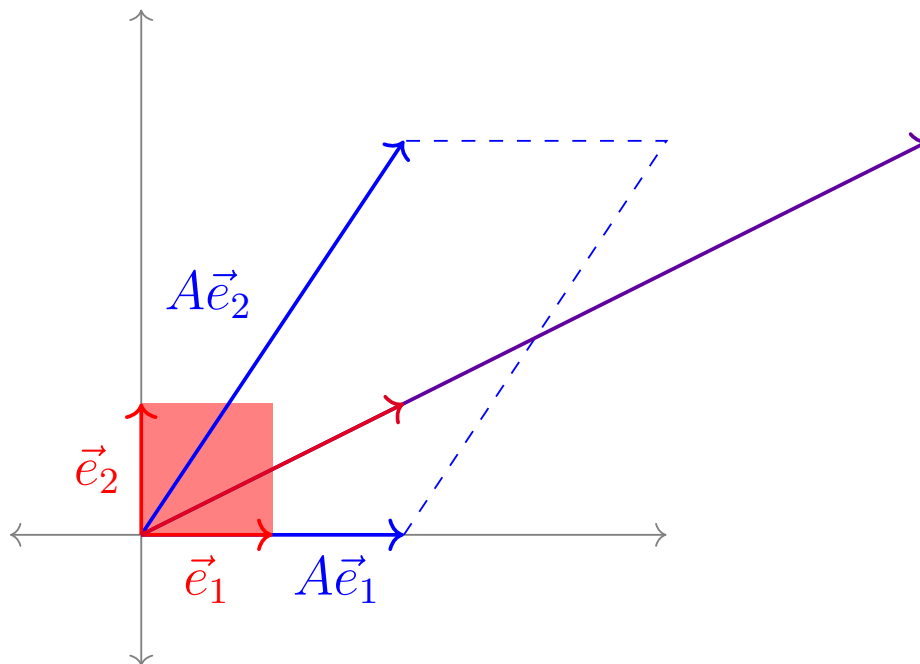

Figure 59 Transformation of the unit square by the linear transformation A

It is easy to see geometrically that

$$A \begin{bmatrix} 1 \\ 0 \end{bmatrix} = \begin{bmatrix} 2 & 2 \\ 0 & 3 \end{bmatrix} \begin{bmatrix} 1 \\ 0 \end{bmatrix} = \begin{bmatrix} 2 \\ 0 \end{bmatrix} = 2 \begin{bmatrix} 1 \\ 0 \end{bmatrix}.$$

It is less obvious (but easily checked once you find it) that

$$A \begin{bmatrix} 2 \\ 1 \end{bmatrix} = \begin{bmatrix} 2 & 2 \\ 0 & 3 \end{bmatrix} \begin{bmatrix} 2 \\ 1 \end{bmatrix} = \begin{bmatrix} 6 \\ 3 \end{bmatrix} = 3 \begin{bmatrix} 2 \\ 1 \end{bmatrix}.$$

Definition 5.3.5 Let $A \in M_{n,n}$. An **eigenvector** for A is a vector $\vec{x} \in \mathbb{R}^n$ such that $A\vec{x}$ is parallel to \vec{x} .

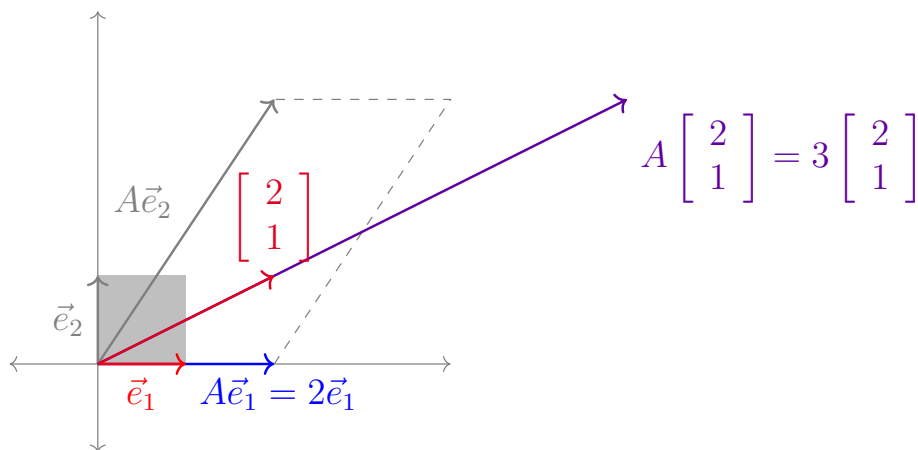

Figure 60 The map A stretches out the eigenvector $\begin{bmatrix} 2 \\ 1 \end{bmatrix}$ by a factor of 3 (the corresponding eigenvalue).

In other words, $A\vec{x} = \lambda\vec{x}$ for some scalar λ . If $\vec{x} \neq \vec{0}$, then we say \vec{x} is a **nontrivial eigenvector** and we call this λ an **eigenvalue** of A . \diamond

Activity 5.3.6 Finding the eigenvalues λ that satisfy

$$A\vec{x} = \lambda\vec{x} = \lambda(I\vec{x}) = (\lambda I)\vec{x}$$

for some nontrivial eigenvector \vec{x} is equivalent to finding nonzero solutions for the matrix equation

$$(A - \lambda I)\vec{x} = \vec{0}.$$

(a) If λ is an eigenvalue, and T is the transformation with standard matrix $A - \lambda I$, which of these must contain a non-zero vector?

- | | |
|----------------------|------------------------|
| A. The kernel of T | C. The domain of T |
| B. The image of T | D. The codomain of T |

(b) Therefore, what can we conclude?

- | | |
|--------------------------|--------------------------------------|
| A. A is invertible | C. $A - \lambda I$ is invertible |
| B. A is not invertible | D. $A - \lambda I$ is not invertible |

(c) And what else?

- | | |
|-----------------|------------------------------|
| A. $\det A = 0$ | C. $\det(A - \lambda I) = 0$ |
| B. $\det A = 1$ | D. $\det(A - \lambda I) = 1$ |

Fact 5.3.7 The eigenvalues λ for a matrix A are exactly the values that make $A - \lambda I$ non-invertible.

Thus the eigenvalues λ for a matrix A are the solutions to the equation

$$\det(A - \lambda I) = 0.$$

Definition 5.3.8 The expression $\det(A - \lambda I)$ is called the **characteristic polynomial** of A .

For example, when $A = \begin{bmatrix} 1 & 2 \\ 5 & 4 \end{bmatrix}$, we have

$$A - \lambda I = \begin{bmatrix} 1 & 2 \\ 5 & 4 \end{bmatrix} - \begin{bmatrix} \lambda & 0 \\ 0 & \lambda \end{bmatrix} = \begin{bmatrix} 1 - \lambda & 2 \\ 5 & 4 - \lambda \end{bmatrix}.$$

Thus the characteristic polynomial of A is

$$\det \begin{bmatrix} 1 - \lambda & 2 \\ 5 & 4 - \lambda \end{bmatrix} = (1 - \lambda)(4 - \lambda) - (2)(5) = \lambda^2 - 5\lambda - 6$$

and its eigenvalues are the solutions $-1, 6$ to $\lambda^2 - 5\lambda - 6 = 0$. ◇

Activity 5.3.9 Let $A = \begin{bmatrix} 5 & 2 \\ -3 & -2 \end{bmatrix}$.

- (a) Compute $\det(A - \lambda I)$ to determine the characteristic polynomial of A .
- (b) Set this characteristic polynomial equal to zero and factor to determine the eigenvalues of A .

Activity 5.3.10 Find all the eigenvalues for the matrix $A = \begin{bmatrix} 3 & -3 \\ 2 & -4 \end{bmatrix}$.

Activity 5.3.11 Find all the eigenvalues for the matrix $A = \begin{bmatrix} 1 & -4 \\ 0 & 5 \end{bmatrix}$.

Activity 5.3.12 Find all the eigenvalues for the matrix $A = \begin{bmatrix} 3 & -3 & 1 \\ 0 & -4 & 2 \\ 0 & 0 & 7 \end{bmatrix}$.

5.3.3 Individual Practice

Activity 5.3.13 Let $A \in M_{n,n}$ and $\lambda \in \mathbb{R}$. The eigenvalues of A that correspond to λ are the vectors that get stretched by a factor of λ . Consider the following special cases for which we can make more geometric meaning.

- (a) What are some other ways we can think of the eigenvalues corresponding to eigenvalue $\lambda = 0$?
- (b) What are some other ways we can think of the eigenvalues corresponding to eigenvalue $\lambda = 1$?
- (c) What are some other ways we can think of the eigenvalues corresponding to eigenvalue

$$\lambda = -1?$$

(d) How might we interpret a matrix that has no (real) eigenvectors/values?

5.3.4 Videos

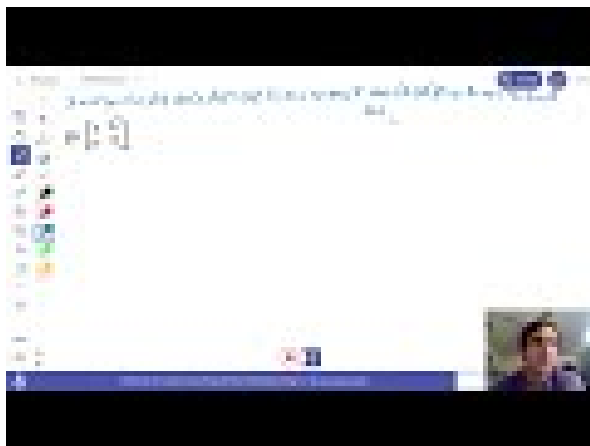

Standalone

Figure 61 Video: Finding eigenvalues

5.3.5 Exercises

Exercises available at <https://tbil.org/linear-algebra/preview/exercises/#/bank/GT3/>.

5.3.6 Mathematical Writing Explorations

Exploration 5.3.14 What are the maximum and minimum number of eigenvalues associated with an $n \times n$ matrix? Write small examples to convince yourself you are correct, and then prove this in generality.

5.3.7 Sample Problem and Solution

Sample problem [Example B.1.24](#).

5.4 Eigenvectors and Eigenspaces (GT4)

Learning Outcomes

- Find a basis for the eigenspace of a 4×4 matrix associated with a given eigenvalue.

5.4.1 Warm Up

Activity 5.4.1 Which of the following vectors is an eigenvector for $A =$

$$\begin{bmatrix} 2 & 4 & -1 & -5 \\ 0 & 0 & -3 & -9 \\ 1 & 1 & 0 & 2 \\ -2 & -2 & 3 & 5 \end{bmatrix}?$$

A. $\begin{bmatrix} -2 \\ 1 \\ 0 \\ 1 \end{bmatrix}$

B. $\begin{bmatrix} -3 \\ 3 \\ -2 \\ 1 \end{bmatrix}$

5.4.2 Class Activities

Activity 5.4.2 It's possible to show that -2 is an eigenvalue for $\begin{bmatrix} -1 & 4 & -2 \\ 2 & -7 & 9 \\ 3 & 0 & 4 \end{bmatrix}$.

Compute the kernel of the transformation with standard matrix

$$A - (-2)I = \begin{bmatrix} ? & 4 & -2 \\ 2 & ? & 9 \\ 3 & 0 & ? \end{bmatrix}$$

to find all the eigenvectors \vec{x} such that $A\vec{x} = -2\vec{x}$.

Definition 5.4.3 Since the kernel of a linear map is a subspace of \mathbb{R}^n , and the kernel obtained from $A - \lambda I$ contains all the eigenvectors associated with λ , we call this kernel the **eigenspace** of A associated with λ . \diamond

Activity 5.4.4 Find a basis for the eigenspace for the matrix $\begin{bmatrix} 0 & 0 & 3 \\ 1 & 0 & -1 \\ 0 & 1 & 3 \end{bmatrix}$ associated with the eigenvalue 3.

Activity 5.4.5 Find a basis for the eigenspace for the matrix $\begin{bmatrix} 5 & -2 & 0 & 4 \\ 6 & -2 & 1 & 5 \\ -2 & 1 & 2 & -3 \\ 4 & 5 & -3 & 6 \end{bmatrix}$ associated with the eigenvalue 1.

Activity 5.4.6 Find a basis for the eigenspace for the matrix $\begin{bmatrix} 4 & 3 & 0 & 0 \\ 3 & 3 & 0 & 0 \\ 0 & 0 & 2 & 5 \\ 0 & 0 & 0 & 2 \end{bmatrix}$ associated with the eigenvalue 2.

5.4.3 Individual Practice

Activity 5.4.7 Suppose that $T: \mathbb{R}^2 \rightarrow \mathbb{R}^2$ is a linear transformation with standard matrix A . Further, suppose that we know that $\vec{u} = \begin{bmatrix} 1 \\ -1 \end{bmatrix}$ and $\vec{v} = \begin{bmatrix} 2 \\ -3 \end{bmatrix}$ are eigenvectors corresponding to eigenvalues 2 and -3 respectively.

- Express the vector $\vec{w} = \begin{bmatrix} 2 \\ 1 \end{bmatrix}$ as a linear combination of \vec{u}, \vec{v} .
- Determine $T(\vec{w})$.

5.4.4 Videos

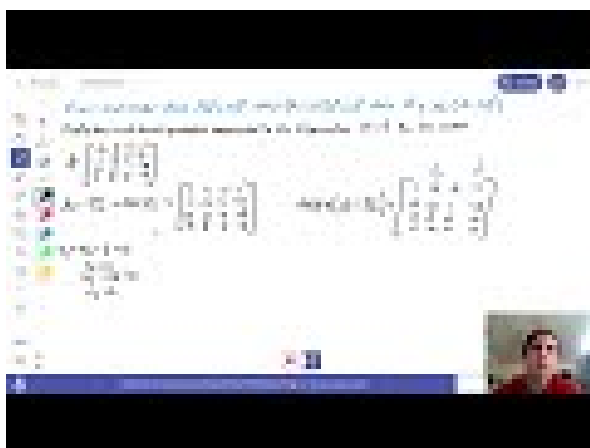

Figure 62 Video: Finding eigenvectors



Standalone

5.4.5 Exercises

Exercises available at <https://tbil.org/linear-algebra/preview/exercises/#/bank/GT4/>.

5.4.6 Mathematical Writing Explorations

Exploration 5.4.8 Given a matrix A , let $\{\vec{v}_1, \vec{v}_2, \dots, \vec{v}_n\}$ be the eigenvectors with associated distinct eigenvalues $\{\lambda_1, \lambda_2, \dots, \lambda_n\}$. Prove the set of eigenvectors is linearly independent.

5.4.7 Sample Problem and Solution

Sample problem [Example B.1.25](#).

Appendix A

Applications

A.1 Civil Engineering: Trusses and Struts

A.1.1 Activities

Definition A.1.1 In engineering, a **truss** is a structure designed from several beams of material called **struts**, assembled to behave as a single object.



Figure 63 A simple truss

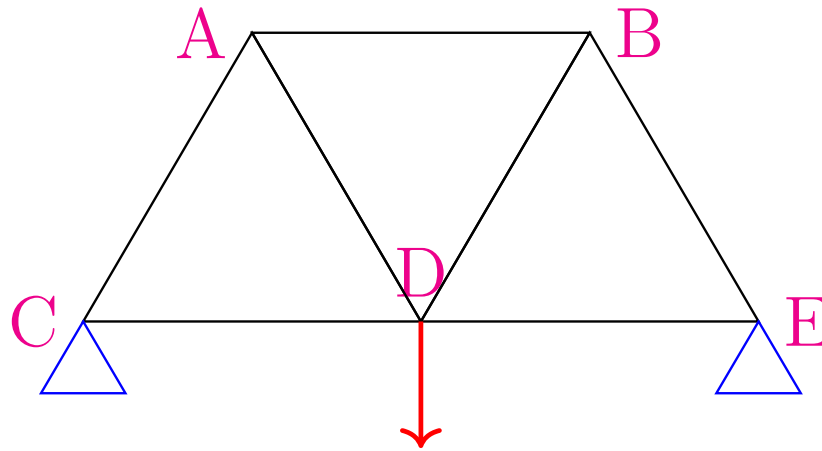

Figure 64 A simple truss



Activity A.1.2 Consider the representation of a simple truss pictured below. All of the seven struts are of equal length, affixed to two anchor points applying a normal force to nodes C and E , and with a $10000N$ load applied to the node given by D .

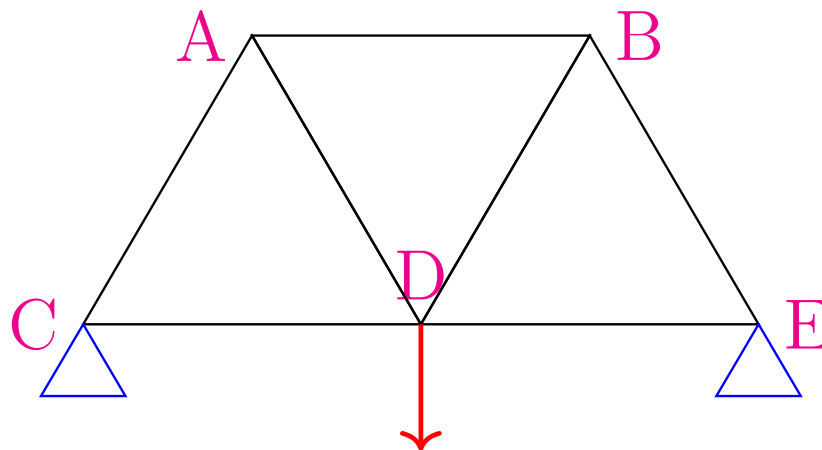

Figure 65 A simple truss

Which of the following must hold for the truss to be stable?

1. All of the struts will experience compression.
2. All of the struts will experience tension.
3. Some of the struts will be compressed, but others will be tensioned.

Observation A.1.3 Since the forces must balance at each node for the truss to be stable, some of the struts will be compressed, while others will be tensioned.

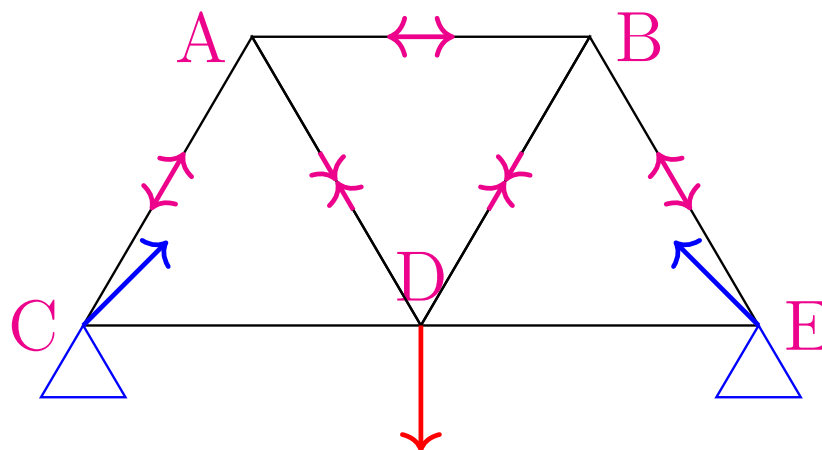

Figure 66 Completed truss

By finding vector equations that must hold at each node, we may determine many of the forces at play.

Remark A.1.4 For example, at the bottom left node there are 3 forces acting.

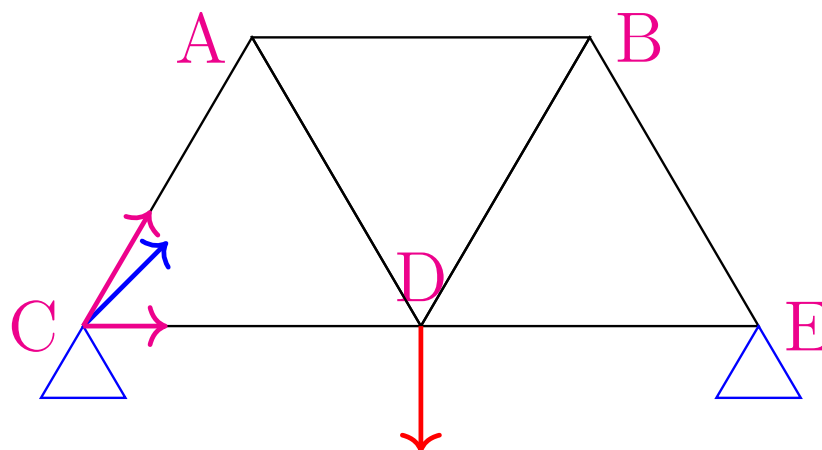

Figure 67 Truss with forces

Let \vec{F}_{CA} be the force on C given by the compression/tension of the strut CA , let \vec{F}_{CD} be defined similarly, and let \vec{N}_C be the normal force of the anchor point on C .

For the truss to be stable, we must have:

$$\vec{F}_{CA} + \vec{F}_{CD} + \vec{N}_C = \vec{0}$$

Activity A.1.5 Using the conventions of the previous remark, and where \vec{L} represents the load vector on node D , find four more vector equations that must be satisfied for each of the other four nodes of the truss.

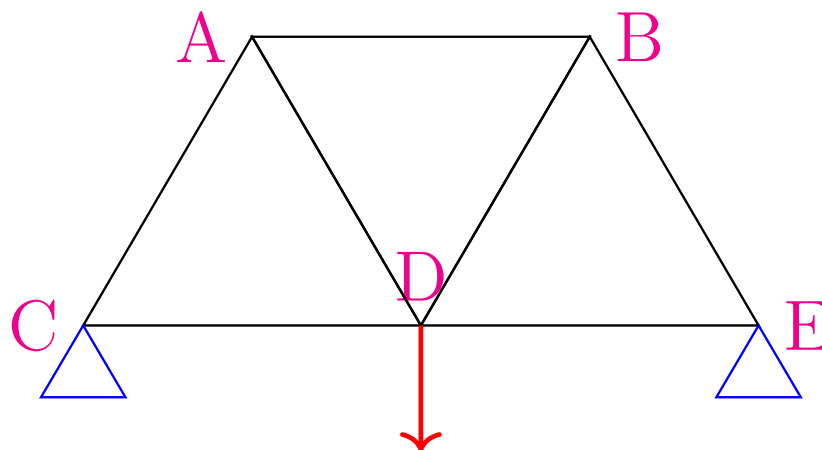

Figure 68 A simple truss

$$A : ?$$

$$B : ?$$

$$C : \vec{F}_{CA} + \vec{F}_{CD} + \vec{N}_C = \vec{0}$$

$$D : ?$$

$$E : ?$$

Remark A.1.6 The five vector equations may be written as follows.

$$A : \vec{F}_{AC} + \vec{F}_{AD} + \vec{F}_{AB} = \vec{0}$$

$$B : \vec{F}_{BA} + \vec{F}_{BD} + \vec{F}_{BE} = \vec{0}$$

$$C : \vec{F}_{CA} + \vec{F}_{CD} + \vec{N}_C = \vec{0}$$

$$D : \vec{F}_{DC} + \vec{F}_{DA} + \vec{F}_{DB} + \vec{F}_{DE} + \vec{L} = \vec{0}$$

$$E : \vec{F}_{EB} + \vec{F}_{ED} + \vec{N}_E = \vec{0}$$

Observation A.1.7 Each vector has a vertical and horizontal component, so it may be treated as a vector in \mathbb{R}^2 . Note that \vec{F}_{CA} must have the same magnitude (but opposite direction) as \vec{F}_{AC} .

$$\vec{F}_{CA} = x \begin{bmatrix} \cos(60^\circ) \\ \sin(60^\circ) \end{bmatrix} = x \begin{bmatrix} 1/2 \\ \sqrt{3}/2 \end{bmatrix}$$

$$\vec{F}_{AC} = x \begin{bmatrix} \cos(-120^\circ) \\ \sin(-120^\circ) \end{bmatrix} = x \begin{bmatrix} -1/2 \\ -\sqrt{3}/2 \end{bmatrix}$$

Activity A.1.8 To write a linear system that models the truss under consideration with constant load 10000 newtons, how many scalar variables will be required?

- 7: 5 from the nodes, 2 from the anchors
- 9: 7 from the struts, 2 from the anchors

- 11: 7 from the struts, 4 from the anchors
- 12: 7 from the struts, 4 from the anchors, 1 from the load
- 13: 5 from the nodes, 7 from the struts, 1 from the load

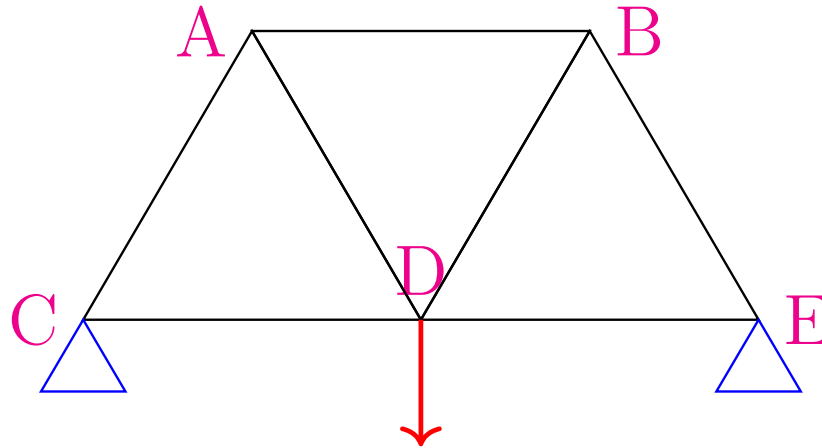

Figure 69 A simple truss

Observation A.1.9 Since the angles for each strut are known, one variable may be used to represent each.

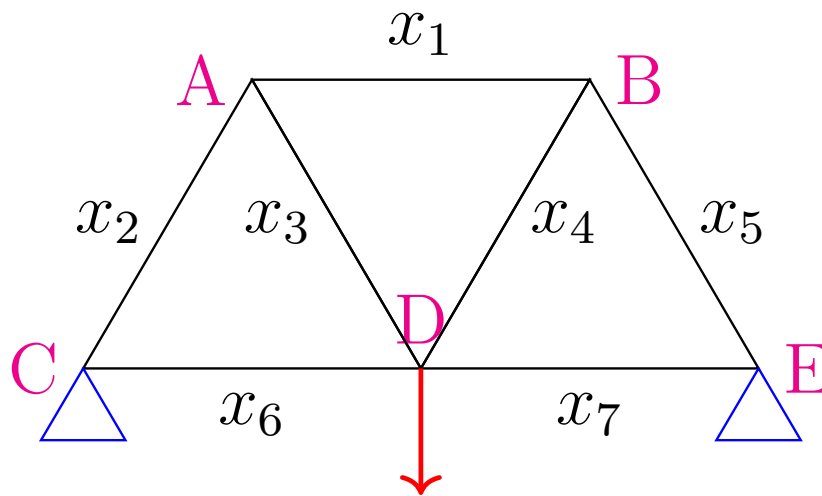

Figure 70 Variables for the truss

For example:

$$\vec{F}_{AB} = -\vec{F}_{BA} = x_1 \begin{bmatrix} \cos(0) \\ \sin(0) \end{bmatrix} = x_1 \begin{bmatrix} 1 \\ 0 \end{bmatrix}$$

$$\vec{F}_{BE} = -\vec{F}_{EB} = x_5 \begin{bmatrix} \cos(-60^\circ) \\ \sin(-60^\circ) \end{bmatrix} = x_5 \begin{bmatrix} 1/2 \\ -\sqrt{3}/2 \end{bmatrix}$$

Observation A.1.10 Since the angle of the normal forces for each anchor point are unknown, two variables may be used to represent each.

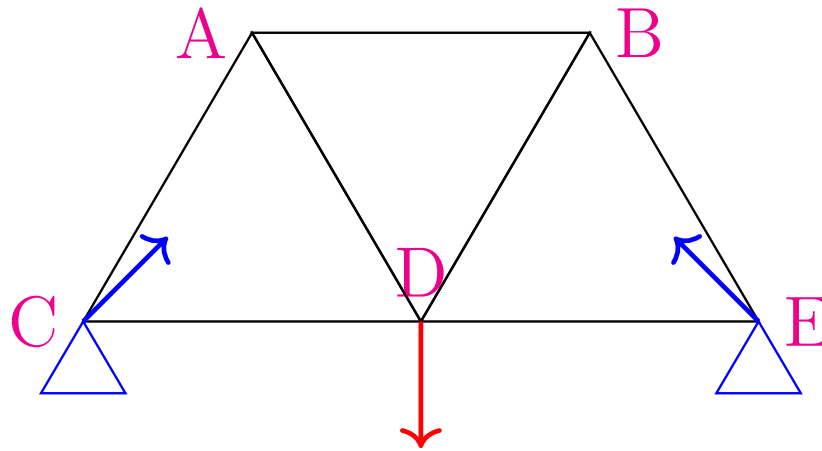

Figure 71 Truss with normal forces

$$\vec{N}_C = \begin{bmatrix} y_1 \\ y_2 \end{bmatrix} \quad \vec{N}_D = \begin{bmatrix} z_1 \\ z_2 \end{bmatrix}$$

The load vector is constant.

$$\vec{L} = \begin{bmatrix} 0 \\ -10000 \end{bmatrix}$$

Remark A.1.11 Each of the five vector equations found previously represent two linear equations: one for the horizontal component and one for the vertical.

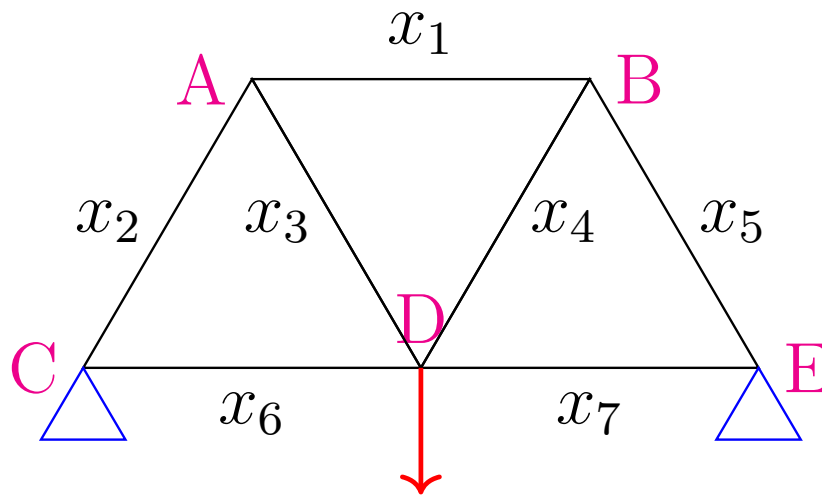

Figure 72 Variables for the truss

$$\begin{aligned} C : \vec{F}_{CA} + \vec{F}_{CD} + \vec{N}_C &= \vec{0} \\ \Leftrightarrow x_2 \begin{bmatrix} \cos(60^\circ) \\ \sin(60^\circ) \end{bmatrix} + x_6 \begin{bmatrix} \cos(0^\circ) \\ \sin(0^\circ) \end{bmatrix} + \begin{bmatrix} y_1 \\ y_2 \end{bmatrix} &= \begin{bmatrix} 0 \\ 0 \end{bmatrix} \end{aligned}$$

Observation A.1.14 This matrix row-reduces to the following.

$$\sim \left[\begin{array}{cccccccccccc|c} 1 & 0 & 0 & 0 & 0 & 0 & 0 & 0 & 0 & 0 & 0 & -5773.7 \\ 0 & 1 & 0 & 0 & 0 & 0 & 0 & 0 & 0 & 0 & 0 & -5773.7 \\ 0 & 0 & 1 & 0 & 0 & 0 & 0 & 0 & 0 & 0 & 0 & 5773.7 \\ 0 & 0 & 0 & 1 & 0 & 0 & 0 & 0 & 0 & 0 & 0 & 5773.7 \\ 0 & 0 & 0 & 0 & 1 & 0 & 0 & 0 & 0 & 0 & 0 & -5773.7 \\ 0 & 0 & 0 & 0 & 0 & 1 & 0 & 0 & 0 & -1 & 0 & 2886.8 \\ 0 & 0 & 0 & 0 & 0 & 0 & 1 & 0 & 0 & -1 & 0 & 2886.8 \\ 0 & 0 & 0 & 0 & 0 & 0 & 0 & 1 & 0 & 1 & 0 & 0 \\ 0 & 0 & 0 & 0 & 0 & 0 & 0 & 0 & 1 & 0 & 0 & 5000 \\ 0 & 0 & 0 & 0 & 0 & 0 & 0 & 0 & 0 & 0 & 1 & 5000 \end{array} \right]$$

Observation A.1.15 Thus we know the truss must satisfy the following conditions.

$$\begin{aligned} x_1 &= x_2 = x_5 = -5882.4 \\ x_3 &= x_4 = 5882.4 \\ x_6 &= x_7 = 2886.8 + z_1 \\ y_1 &= -z_1 \\ y_2 &= z_2 = 5000 \end{aligned}$$

In particular, the negative x_1, x_2, x_5 represent tension (forces pointing into the nodes), and the positive x_3, x_4 represent compression (forces pointing out of the nodes). The vertical normal forces $y_2 + z_2$ counteract the 10000 load.

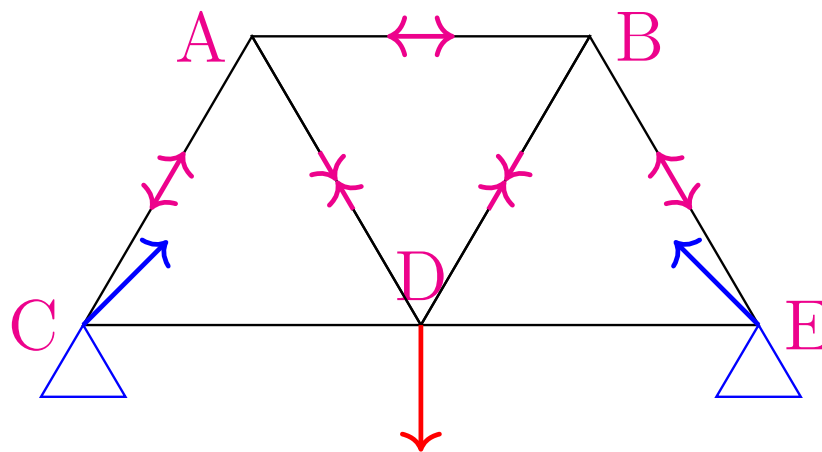

Figure 74 Completed truss

A.2 Computer Science: PageRank

A.2.1 Activities

Activity A.2.1 The \$978,000,000,000 Problem.

In the picture below, each circle represents a webpage, and each arrow represents a link from one page to another.

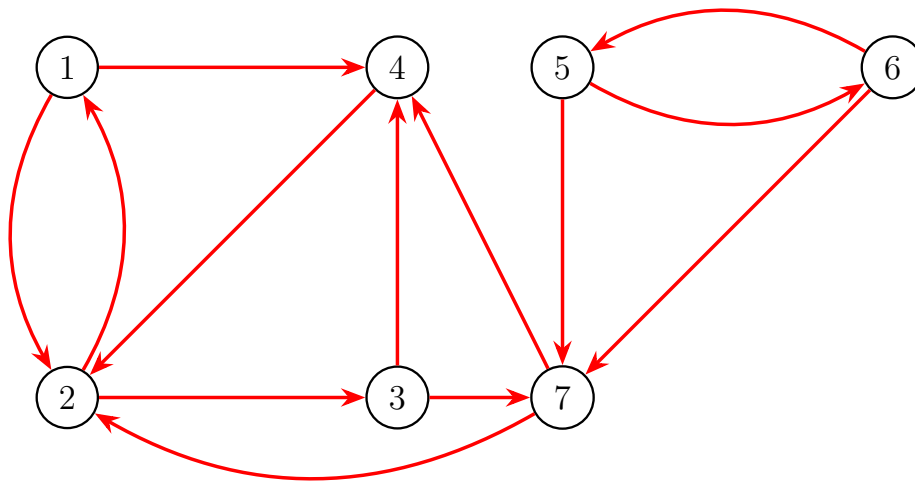

Figure 75 A seven-webpage network

Based on how these pages link to each other, write a list of the 7 webpages in order from most important to least important.

Observation A.2.2 The \$978,000,000,000 Idea. Links are endorsements. That is:

1. A webpage is important if it is linked to (endorsed) by important pages.
2. A webpage distributes its importance equally among all the pages it links to (endorses).

Consider this small network with only three pages. Let x_1, x_2, x_3 be the importance of the three pages respectively.

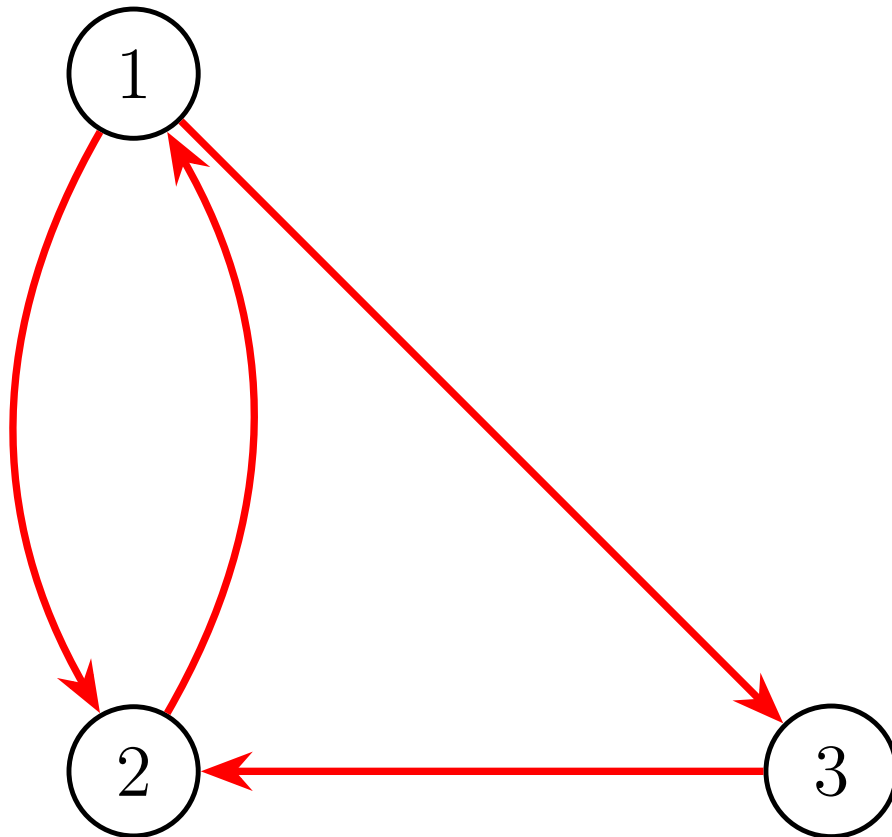

Figure 76 A three-webpage network

1. x_1 splits its endorsement in half between x_2 and x_3
2. x_2 sends all of its endorsement to x_1
3. x_3 sends all of its endorsement to x_2 .

This corresponds to the **page rank system**:

$$\begin{aligned}
 x_2 &= x_1 \\
 \frac{1}{2}x_1 + x_3 &= x_2 \\
 \frac{1}{2}x_1 &= x_3
 \end{aligned}$$

□

Observation A.2.4

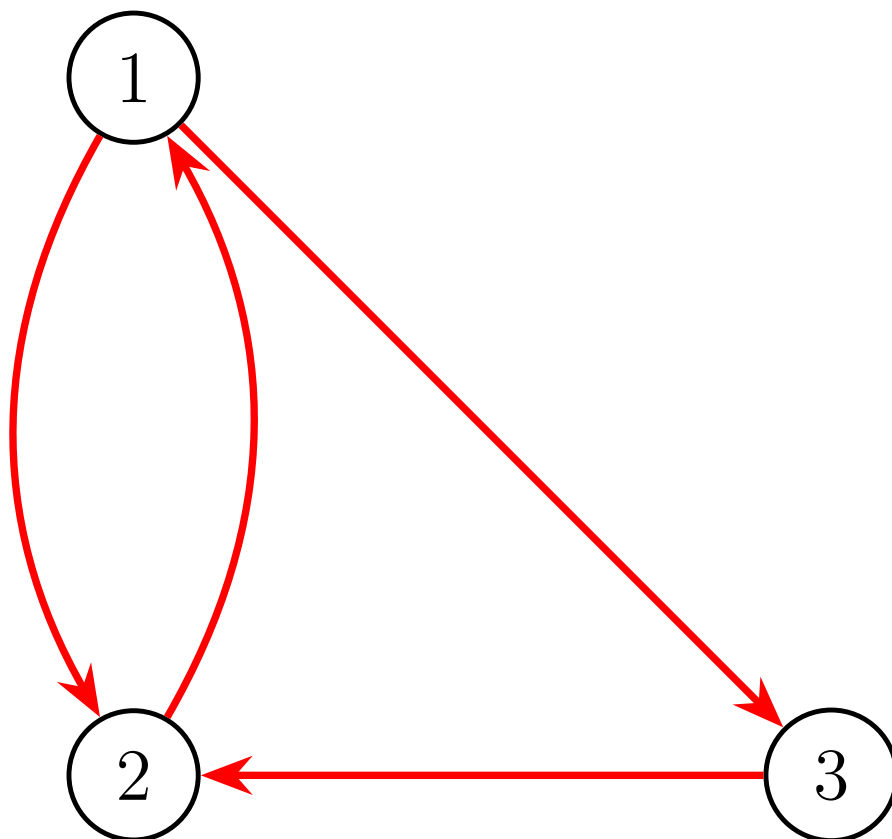

Figure 77 A three-webpage network

$$\begin{array}{rcl}
 x_2 & = & x_1 \\
 \frac{1}{2}x_1 + x_3 & = & x_2 \\
 \frac{1}{2}x_1 & = & x_3
 \end{array}
 \qquad
 \begin{bmatrix} 0 & 1 & 0 \\ \frac{1}{2} & 0 & 1 \\ \frac{1}{2} & 0 & 0 \end{bmatrix}
 \begin{bmatrix} x_1 \\ x_2 \\ x_3 \end{bmatrix}
 =
 \begin{bmatrix} x_1 \\ x_2 \\ x_3 \end{bmatrix}$$

By writing this linear system in terms of matrix multiplication, we obtain the **page rank matrix** $A = \begin{bmatrix} 0 & 1 & 0 \\ \frac{1}{2} & 0 & 1 \\ \frac{1}{2} & 0 & 0 \end{bmatrix}$ and page rank vector $\vec{x} = \begin{bmatrix} x_1 \\ x_2 \\ x_3 \end{bmatrix}$.

Thus, computing the importance of pages on a network is equivalent to solving the matrix equation $A\vec{x} = 1\vec{x}$.

Activity A.2.5 Thus, our \$978,000,000,000 problem is what kind of problem?

$$\begin{bmatrix} 0 & 1 & 0 \\ \frac{1}{2} & 0 & \frac{1}{2} \\ \frac{1}{2} & 0 & 0 \end{bmatrix}
 \begin{bmatrix} x_1 \\ x_2 \\ x_3 \end{bmatrix}
 = 1
 \begin{bmatrix} x_1 \\ x_2 \\ x_3 \end{bmatrix}$$

- A. An antiderivative problem
- B. A bijection problem

- C. A cofactoring problem
- D. A determinant problem
- E. An eigenvector problem

Activity A.2.6 Find a page rank vector \vec{x} satisfying $A\vec{x} = 1\vec{x}$ for the following network's page rank matrix A .

That is, find the eigenspace associated with $\lambda = 1$ for the matrix A , and choose a vector from that eigenspace.

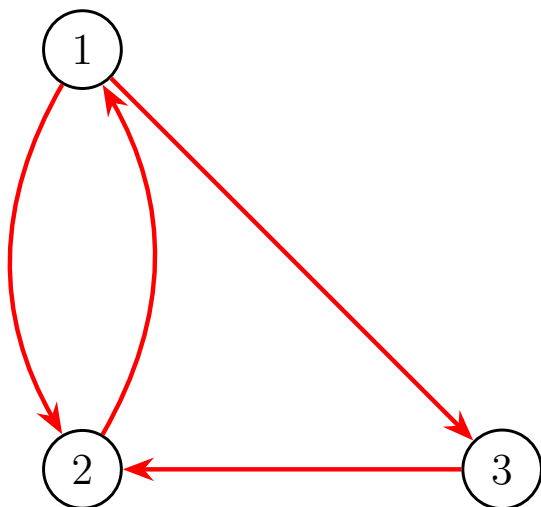

$$A = \begin{bmatrix} 0 & 1 & 0 \\ \frac{1}{2} & 0 & 1 \\ \frac{1}{2} & 0 & 0 \end{bmatrix}$$

Figure 78 A three-webpage network

Observation A.2.7 Row-reducing $A - I = \begin{bmatrix} -1 & 1 & 0 \\ \frac{1}{2} & -1 & 1 \\ \frac{1}{2} & 0 & -1 \end{bmatrix} \sim \begin{bmatrix} 1 & 0 & -2 \\ 0 & 1 & -2 \\ 0 & 0 & 0 \end{bmatrix}$ yields the

basic eigenvector $\begin{bmatrix} 2 \\ 2 \\ 1 \end{bmatrix}$.

Therefore, we may conclude that pages 1 and 2 are equally important, and both pages are twice as important as page 3.

Activity A.2.8 Compute the 7×7 page rank matrix for the following network.

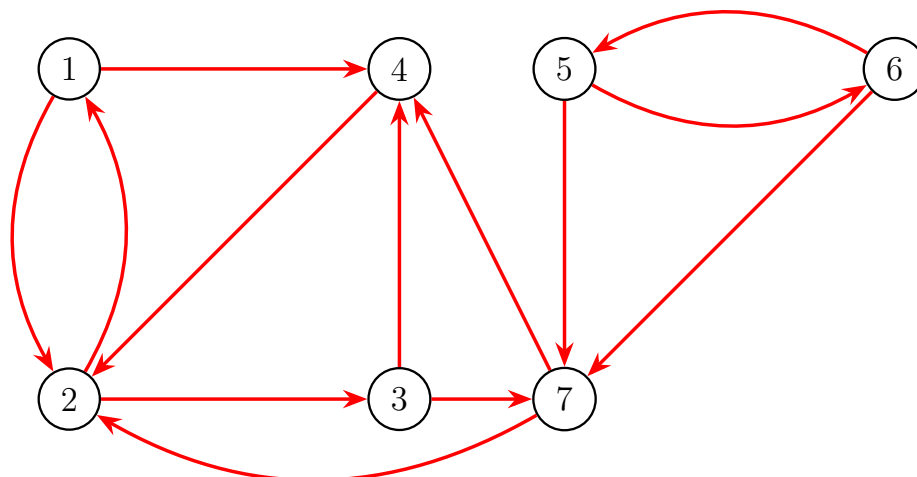

Figure 79 A seven-webpage network

For example, since website 1 distributes its endorsement equally between 2 and 4, the

first column is
$$\begin{bmatrix} 0 \\ \frac{1}{2} \\ 0 \\ \frac{1}{2} \\ 0 \\ 0 \\ 0 \end{bmatrix}.$$

Activity A.2.9 Find a page rank vector for the given page rank matrix.

$$A = \begin{bmatrix} 0 & \frac{1}{2} & 0 & 0 & 0 & 0 & 0 \\ \frac{1}{2} & 0 & 0 & 1 & 0 & 0 & \frac{1}{2} \\ 0 & \frac{1}{2} & 0 & 0 & 0 & 0 & 0 \\ \frac{1}{2} & 0 & \frac{1}{2} & 0 & 0 & 0 & \frac{1}{2} \\ 0 & 0 & 0 & 0 & 0 & \frac{1}{2} & 0 \\ 0 & 0 & 0 & 0 & \frac{1}{2} & 0 & 0 \\ 0 & 0 & \frac{1}{2} & 0 & \frac{1}{2} & \frac{1}{2} & 0 \end{bmatrix}$$

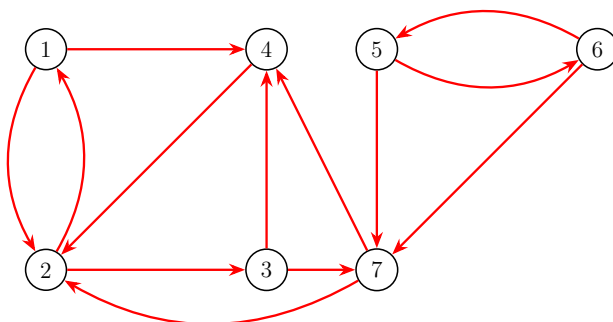

Figure 80 A seven-webpage network

Which webpage is most important?

Observation A.2.10 Since a page rank vector for the network is given by \vec{x} , it's reasonable

to consider page 2 as the most important page.

$$\vec{x} = \begin{bmatrix} 2 \\ 4 \\ 2 \\ 2.5 \\ 0 \\ 0 \\ 1 \end{bmatrix}$$

Based upon this page rank vector, here is a complete ranking of all seven pages from most important to least important:

2, 4, 1, 3, 7, 5, 6

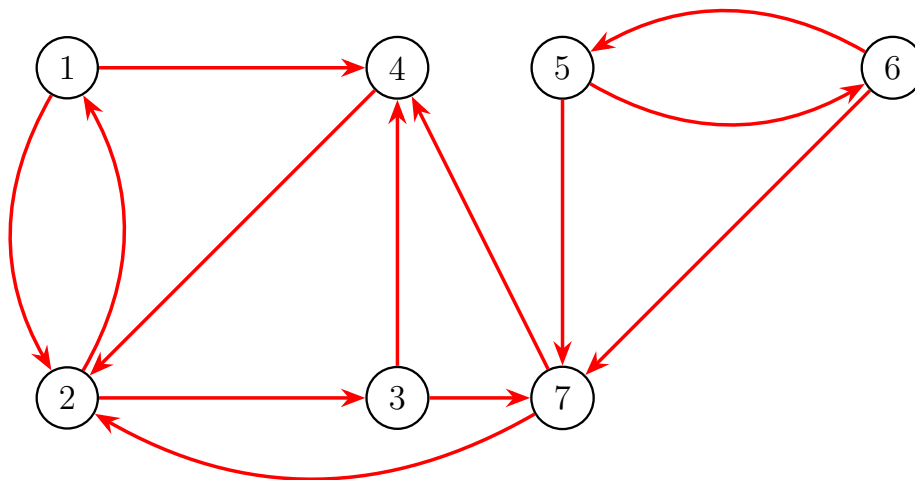

Figure 81 A seven-webpage network

Activity A.2.11 Given the following diagram, use a page rank vector to rank the pages 1 through 7 in order from most important to least important.

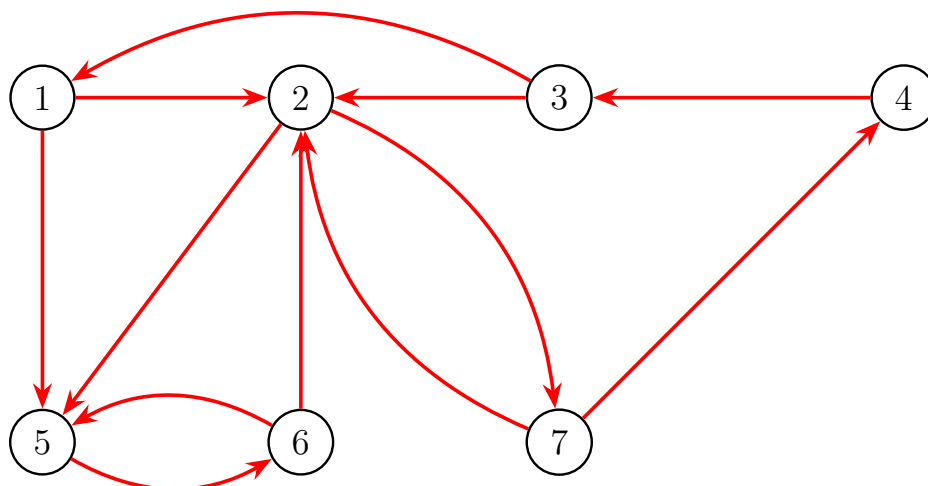

Figure 82 Another seven-webpage network

A.3 Geology: Phases and Components

A.3.1 Activities

Definition A.3.1 In geology, a **phase** is any physically separable material in the system, such as various minerals or liquids.

A **component** is a chemical compound necessary to make up the phases; these are usually oxides such as Calcium Oxide (CaO) or Silicon Dioxide (SiO₂).

In a typical application, a geologist knows how to build each phase from the components, and is interested in determining reactions among the different phases. \diamond

Observation A.3.2 Consider the 3 components

$$\vec{c}_1 = \text{CaO} \quad \vec{c}_2 = \text{MgO} \quad \text{and} \quad \vec{c}_3 = \text{SiO}_2$$

and the 5 phases:

$$\begin{array}{lll} \vec{p}_1 = \text{Ca}_3\text{MgSi}_2\text{O}_8 & \vec{p}_2 = \text{CaMgSiO}_4 & \vec{p}_3 = \text{CaSiO}_3 \\ \vec{p}_4 = \text{CaMgSi}_2\text{O}_6 & \vec{p}_5 = \text{Ca}_2\text{MgSi}_2\text{O}_7 & \end{array}$$

Geologists already know (or can easily deduce) that

$$\begin{array}{lll} \vec{p}_1 = 3\vec{c}_1 + \vec{c}_2 + 2\vec{c}_3 & \vec{p}_2 = \vec{c}_1 + \vec{c}_2 + \vec{c}_3 & \vec{p}_3 = \vec{c}_1 + 0\vec{c}_2 + \vec{c}_3 \\ \vec{p}_4 = \vec{c}_1 + \vec{c}_2 + 2\vec{c}_3 & \vec{p}_5 = 2\vec{c}_1 + \vec{c}_2 + 2\vec{c}_3 & \end{array}$$

since, for example:

$$\vec{c}_1 + \vec{c}_3 = \text{CaO} + \text{SiO}_2 = \text{CaSiO}_3 = \vec{p}_3$$

Activity A.3.3 To study this vector space, each of the three components $\vec{c}_1, \vec{c}_2, \vec{c}_3$ may be

considered as the three components of a Euclidean vector.

$$\vec{p}_1 = \begin{bmatrix} 3 \\ 1 \\ 2 \end{bmatrix}, \vec{p}_2 = \begin{bmatrix} 1 \\ 1 \\ 1 \end{bmatrix}, \vec{p}_3 = \begin{bmatrix} 1 \\ 0 \\ 1 \end{bmatrix}, \vec{p}_4 = \begin{bmatrix} 1 \\ 1 \\ 2 \end{bmatrix}, \vec{p}_5 = \begin{bmatrix} 2 \\ 1 \\ 2 \end{bmatrix}.$$

Determine if the set of phases is linearly dependent or linearly independent.

Activity A.3.4 Geologists are interested in knowing all the possible chemical reactions among the 5 phases:

$$\begin{aligned} \vec{p}_1 = \text{Ca}_3\text{MgSi}_2\text{O}_8 &= \begin{bmatrix} 3 \\ 1 \\ 2 \end{bmatrix} & \vec{p}_2 = \text{CaMgSiO}_4 &= \begin{bmatrix} 1 \\ 1 \\ 1 \end{bmatrix} & \vec{p}_3 = \text{CaSiO}_3 &= \begin{bmatrix} 1 \\ 0 \\ 1 \end{bmatrix} \\ \vec{p}_4 = \text{CaMgSi}_2\text{O}_6 &= \begin{bmatrix} 1 \\ 1 \\ 2 \end{bmatrix} & \vec{p}_5 = \text{Ca}_2\text{MgSi}_2\text{O}_7 &= \begin{bmatrix} 2 \\ 1 \\ 2 \end{bmatrix}. \end{aligned}$$

That is, they want to find numbers x_1, x_2, x_3, x_4, x_5 such that

$$x_1\vec{p}_1 + x_2\vec{p}_2 + x_3\vec{p}_3 + x_4\vec{p}_4 + x_5\vec{p}_5 = 0.$$

- Set up a system of equations equivalent to this vector equation.
- Find a basis for its solution space.
- Interpret each basis vector as a vector equation and a chemical equation.

Activity A.3.5 We found two basis vectors $\begin{bmatrix} 1 \\ -2 \\ -2 \\ 1 \\ 0 \end{bmatrix}$ and $\begin{bmatrix} 0 \\ -1 \\ -1 \\ 0 \\ 1 \end{bmatrix}$, corresponding to the

vector and chemical equations

$$\begin{aligned} 2\vec{p}_2 + 2\vec{p}_3 &= \vec{p}_1 + \vec{p}_4 & 2\text{CaMgSiO}_4 + 2\text{CaSiO}_3 &= \text{Ca}_3\text{MgSi}_2\text{O}_8 + \text{CaMgSi}_2\text{O}_6 \\ \vec{p}_2 + \vec{p}_3 &= \vec{p}_5 & \text{CaMgSiO}_4 + \text{CaSiO}_3 &= \text{Ca}_2\text{MgSi}_2\text{O}_7 \end{aligned}$$

Combine the basis vectors to produce a chemical equation among the five phases that does not involve $\vec{p}_2 = \text{CaMgSiO}_4$.

Appendix B

Appendix

B.1 Sample Exercises with Solutions

Here we model one exercise and solution for each learning objective. Your solutions should not look identical to those shown below, but these solutions can give you an idea of the level of detail required for a complete solution.

Consider the vector equation

$$x_1 \begin{bmatrix} 4 \\ -3 \\ 3 \end{bmatrix} + x_2 \begin{bmatrix} 4 \\ -3 \\ 3 \end{bmatrix} + x_3 \begin{bmatrix} 3 \\ 1 \\ 3 \end{bmatrix} + x_4 \begin{bmatrix} 18 \\ -7 \\ 15 \end{bmatrix} = \begin{bmatrix} -11 \\ 5 \\ -9 \end{bmatrix}$$

(a) Write a corresponding system of equations.

Solution.

$$\begin{aligned} 4x_1 + 4x_2 + 3x_3 + 18x_4 &= -11 \\ -3x_1 - 3x_2 + x_3 - 7x_4 &= 5 \\ 3x_1 + 3x_2 + 3x_3 + 15x_4 &= -9 \end{aligned}$$

(b) Write a corresponding augmented matrix.

Solution.

$$\left[\begin{array}{cccc|c} 4 & 4 & 3 & 18 & -11 \\ -3 & -3 & 1 & -7 & 5 \\ 3 & 3 & 3 & 15 & -9 \end{array} \right]$$

□

(a) For each of the following matrices, explain why it is not in reduced row echelon form.

(i)

$$A = \begin{bmatrix} 0 & 0 & 1 & 0 & -2 \\ 1 & 5 & 0 & -2 & 1 \\ 0 & 0 & 0 & 0 & 0 \end{bmatrix}$$

Solution. $A = \begin{bmatrix} 0 & 0 & \boxed{1} & 0 & -2 \\ \boxed{1} & 5 & 0 & -2 & 1 \\ 0 & 0 & 0 & 0 & 0 \end{bmatrix}$ is not in reduced row echelon form because the pivots are not descending to the right.

(ii)

$$B = \begin{bmatrix} 1 & -6 & 3 & 0 & -1 \\ 0 & 0 & 0 & 7 & 14 \\ 0 & 0 & 0 & 0 & 0 \end{bmatrix}$$

Solution. $B = \begin{bmatrix} \boxed{1} & -6 & 3 & 0 & -1 \\ 0 & 0 & 0 & \boxed{7} & 14 \\ 0 & 0 & 0 & 0 & 0 \end{bmatrix}$ is not in reduced row echelon form because a leading term has a value besides 1.

(iii)

$$C = \begin{bmatrix} 1 & 7 & -4 & 1 & 12 \\ 0 & 1 & -1 & 0 & 2 \\ 0 & 0 & 0 & 0 & 0 \end{bmatrix}$$

Solution. $C = \begin{bmatrix} \boxed{1} & 7 & -4 & 1 & 12 \\ 0 & \boxed{1} & -1 & 0 & 2 \\ 0 & 0 & 0 & 0 & 0 \end{bmatrix}$ is not in reduced row echelon form because there is a non-zero entry above or below a pivot.

(b) Show step by step why

$$\text{RREF} \begin{bmatrix} 4 & 4 & 3 & 18 & -11 \\ -3 & -3 & 1 & -7 & 5 \\ 3 & 3 & 3 & 15 & -9 \end{bmatrix} = \begin{bmatrix} 1 & 1 & 0 & 3 & -2 \\ 0 & 0 & 1 & 2 & -1 \\ 0 & 0 & 0 & 0 & 0 \end{bmatrix}$$

Solution.

$$\begin{aligned} \begin{bmatrix} 4 & 4 & 3 & 18 & -11 \\ -3 & -3 & 1 & -7 & 5 \\ 3 & 3 & 3 & 15 & -9 \end{bmatrix} &\xrightarrow{R_1+R_2 \rightarrow R_1} \begin{bmatrix} \boxed{1} & 1 & 4 & 11 & -6 \\ -3 & -3 & 1 & -7 & 5 \\ 3 & 3 & 3 & 15 & -9 \end{bmatrix} \\ &\xrightarrow{\substack{R_2+3R_1 \rightarrow R_2 \\ R_3-3R_1 \rightarrow R_3}} \begin{bmatrix} \boxed{1} & 1 & 4 & 11 & -6 \\ 0 & 0 & 13 & 26 & -13 \\ 0 & 0 & -9 & -18 & 9 \end{bmatrix} \\ &\xrightarrow{\substack{\frac{1}{13}R_2 \rightarrow R_2 \\ \frac{1}{9}R_3 \rightarrow R_3}} \begin{bmatrix} \boxed{1} & 1 & 4 & 11 & -6 \\ 0 & 0 & \boxed{1} & 2 & -1 \\ 0 & 0 & -1 & -2 & 1 \end{bmatrix} \\ &\xrightarrow{\substack{R_1-4R_2 \rightarrow R_1 \\ R_3+R_1 \rightarrow R_3}} \begin{bmatrix} \boxed{1} & 1 & 0 & 3 & -2 \\ 0 & 0 & \boxed{1} & 2 & -1 \\ 0 & 0 & 0 & 0 & 0 \end{bmatrix} \end{aligned}$$

□

Consider each of the following systems of linear equations or vector equations.

(a)

$$\begin{aligned} x_1 - x_2 + x_3 &= 4 \\ x_2 - 2x_3 &= -1 \\ x_2 - 2x_3 &= -3 \\ x_1 + 2x_2 - 5x_3 &= 0 \end{aligned}$$

- (i) Explain and demonstrate how to find a simpler linear system that has the same solution set.

Solution. The given linear system is represented by this augmented matrix, which row reduces as follows:

$$\left[\begin{array}{ccc|c} 1 & -1 & 1 & 4 \\ 0 & 1 & -2 & -1 \\ 0 & 1 & -2 & -3 \\ 1 & 2 & -5 & 0 \end{array} \right] \sim \left[\begin{array}{ccc|c} 1 & 0 & -1 & 0 \\ 0 & 1 & -2 & 0 \\ 0 & 0 & 0 & 1 \\ 0 & 0 & 0 & 0 \end{array} \right]$$

The RREF matrix then yields the following simplified linear system with the same solution set:

$$\begin{aligned} x_1 - x_3 &= 0 \\ x_2 - 2x_3 &= 0 \\ 0 &= 1 \\ 0 &= 0 \end{aligned}$$

- (ii) Explain whether this solution set has no solutions, one solution, or infinitely-many solutions. If the set is finite, describe it using set notation.

Solution. Because $0 = 1$ is false, the solution set has no solutions. This means the solution set is \emptyset .

(b)

$$\begin{aligned} -x_1 + x_2 + x_3 &= 2 \\ -3x_1 + x_2 - 4x_3 &= -9 \\ 2x_1 - x_2 + 2x_3 &= 5 \\ -6x_1 + 3x_2 - 4x_3 &= -9 \end{aligned}$$

- (i) Explain and demonstrate how to find a simpler linear system that has the same solution set.

Solution. The given linear system is represented by this augmented matrix, which row reduces as follows:

$$\left[\begin{array}{ccc|c} -1 & 1 & 1 & 2 \\ -3 & 1 & -4 & -9 \\ 2 & -1 & 2 & 5 \\ -6 & 3 & -4 & -9 \end{array} \right] \sim \left[\begin{array}{ccc|c} 1 & 0 & 0 & -2 \\ 0 & 1 & 0 & -3 \\ 0 & 0 & 1 & 3 \\ 0 & 0 & 0 & 0 \end{array} \right]$$

The RREF matrix then yields the following simplified linear system with the same solution set:

$$\begin{array}{rcl} x_1 & & = -2 \\ & x_2 & = -3 \\ & & x_3 = 3 \\ & & 0 = 0 \end{array}$$

- (ii) Explain whether this solution set has no solutions, one solution, or infinitely-many solutions. If the set is finite, describe it using set notation.

Solution. Since each variable is equal to a fixed value, there exists only one

solution. The solution set is $\left\{ \begin{bmatrix} -2 \\ -3 \\ 3 \end{bmatrix} \right\}$.

(c)

$$\begin{array}{rcl} x_1 & + & 4x_2 - 14x_3 = 11 \\ -x_1 & - & 3x_2 + 11x_3 = -8 \\ -x_1 & - & 3x_2 + 11x_3 = -8 \\ & & 3x_2 - 9x_3 = 9 \end{array}$$

- (i) Explain and demonstrate how to find a simpler linear system that has the same solution set.

Solution. The given linear system is represented by this augmented matrix, which row reduces as follows:

$$\left[\begin{array}{ccc|c} 1 & 4 & -14 & 11 \\ -1 & -3 & 11 & -8 \\ -1 & -3 & 11 & -8 \\ 0 & 3 & -9 & 9 \end{array} \right] \sim \left[\begin{array}{ccc|c} 1 & 0 & -2 & -1 \\ 0 & 1 & -3 & 3 \\ 0 & 0 & 0 & 0 \\ 0 & 0 & 0 & 0 \end{array} \right]$$

The RREF matrix then yields the following simplified linear system with the same solution set:

$$\begin{array}{rcl} x_1 & - & 2x_3 = -1 \\ & x_2 - & 3x_3 = 3 \\ & & 0 = 0 \\ & & 0 = 0 \end{array}$$

- (ii) Explain whether this solution set has no solutions, one solution, or infinitely-many solutions. If the set is finite, describe it using set notation.

Solution. Since the simplified system obtained from the RREF calculation has no contradictions, but has equations with multiple variables, the solution set has infinitely-many solutions.

□

Consider the following vector equation.

$$x_1 \begin{bmatrix} 1 \\ 0 \\ 1 \\ 1 \end{bmatrix} + x_2 \begin{bmatrix} -2 \\ 0 \\ -2 \\ -2 \end{bmatrix} + x_3 \begin{bmatrix} -5 \\ 1 \\ -5 \\ -2 \end{bmatrix} + x_4 \begin{bmatrix} 13 \\ -2 \\ 13 \\ 7 \end{bmatrix} + x_5 \begin{bmatrix} -14 \\ 3 \\ -14 \\ -5 \end{bmatrix} = \begin{bmatrix} 18 \\ -3 \\ 18 \\ 9 \end{bmatrix}$$

(a) Explain how to find a simpler linear system that has the same solution set.

Solution. The given linear system is represented by this augmented matrix, which row reduces as follows:

$$\left[\begin{array}{ccccc|c} 1 & -2 & -5 & 13 & -14 & 18 \\ 0 & 0 & 1 & -2 & 3 & -3 \\ 1 & -2 & -5 & 13 & -14 & 18 \\ 1 & -2 & -2 & 7 & -5 & 9 \end{array} \right] \sim \left[\begin{array}{ccccc|c} 1 & -2 & 0 & 3 & 1 & 3 \\ 0 & 0 & 1 & -2 & 3 & -3 \\ 0 & 0 & 0 & 0 & 0 & 0 \\ 0 & 0 & 0 & 0 & 0 & 0 \end{array} \right]$$

The RREF matrix then yields the following simplified linear system with the same solution set:

$$\begin{array}{rccccrcr} x_1 & - & 2x_2 & & + & 3x_4 & + & x_5 & = & 3 \\ & & & & & x_3 & - & 2x_4 & + & 3x_5 & = & -3 \\ & & & & & & & & & 0 & = & 0 \\ & & & & & & & & & 0 & = & 0 \end{array}$$

(b) Explain how to describe this solution set using set notation.

Solution. We can assign free variables for each of the non-pivot columns: $x_2 = a$, $x_4 = b$, and $x_5 = c$:

$$\begin{array}{rccccrcr} x_1 & - & 2a & & + & 3b & + & c & = & 3 \\ & & & & & x_3 & - & 2b & + & 3c & = & -3 \end{array}$$

Then we may solve for the bound variables x_1 and x_3 :

$$x_1 = 2a - 3b - c + 3$$

$$x_3 = 2b - 3c - 3$$

Therefore, the solution set is $\left\{ \left[\begin{array}{c} 2a - 3b - c + 3 \\ a \\ 2b - 3c - 3 \\ b \\ c \end{array} \right] \mid a, b, c \in \mathbb{R} \right\}$.

□

1. Write a statement involving the solutions of a vector equation that's equivalent to each claim below.

- $\begin{bmatrix} -13 \\ 3 \\ -13 \end{bmatrix}$ is a linear combination of the vectors $\begin{bmatrix} 1 \\ 0 \\ 1 \end{bmatrix}$, $\begin{bmatrix} 2 \\ 0 \\ 2 \end{bmatrix}$, $\begin{bmatrix} 3 \\ 0 \\ 3 \end{bmatrix}$, and $\begin{bmatrix} -5 \\ 1 \\ -5 \end{bmatrix}$.
- $\begin{bmatrix} -13 \\ 3 \\ -15 \end{bmatrix}$ is a linear combination of the vectors $\begin{bmatrix} 1 \\ 0 \\ 1 \end{bmatrix}$, $\begin{bmatrix} 2 \\ 0 \\ 2 \end{bmatrix}$, $\begin{bmatrix} 3 \\ 0 \\ 3 \end{bmatrix}$, and $\begin{bmatrix} -5 \\ 1 \\ -5 \end{bmatrix}$.

2. Use these statements to determine if each vector is or is not a linear combination. If it is, give an example of such a linear combination.

Solution.

- $\begin{bmatrix} -13 \\ 3 \\ -13 \end{bmatrix}$ is a linear combination of the vectors $\begin{bmatrix} 1 \\ 0 \\ 1 \end{bmatrix}$, $\begin{bmatrix} 2 \\ 0 \\ 2 \end{bmatrix}$, $\begin{bmatrix} 3 \\ 0 \\ 3 \end{bmatrix}$, and $\begin{bmatrix} -5 \\ 1 \\ -5 \end{bmatrix}$ exactly when the vector equation

$$x_1 \begin{bmatrix} 1 \\ 0 \\ 1 \end{bmatrix} + x_2 \begin{bmatrix} 2 \\ 0 \\ 2 \end{bmatrix} + x_3 \begin{bmatrix} 3 \\ 0 \\ 3 \end{bmatrix} + x_4 \begin{bmatrix} -5 \\ 1 \\ -5 \end{bmatrix} = \begin{bmatrix} -13 \\ 3 \\ -13 \end{bmatrix}$$

has a solution. To solve this vector equation, we compute

$$\text{RREF} \left[\begin{array}{cccc|c} 1 & 2 & 3 & -5 & -13 \\ 0 & 0 & 0 & 1 & 3 \\ 1 & 2 & 3 & -5 & -13 \end{array} \right] = \left[\begin{array}{cccc|c} 1 & 2 & 3 & 0 & 2 \\ 0 & 0 & 0 & 1 & 3 \\ 0 & 0 & 0 & 0 & 0 \end{array} \right].$$

We see that this vector equation has solution set $\left\{ \begin{bmatrix} 2 - 2a - 3b \\ a \\ b \\ 3 \end{bmatrix} \mid a, b \in \mathbb{R} \right\}$, so

$$\begin{bmatrix} -13 \\ 3 \\ -13 \end{bmatrix} \text{ is a linear combination; for example, } 2 \begin{bmatrix} 1 \\ 0 \\ 1 \end{bmatrix} + 3 \begin{bmatrix} -5 \\ 1 \\ -5 \end{bmatrix} = \begin{bmatrix} -13 \\ 3 \\ -13 \end{bmatrix}$$

- $\begin{bmatrix} -13 \\ 3 \\ -15 \end{bmatrix}$ is a linear combination of the vectors $\begin{bmatrix} 1 \\ 0 \\ 1 \end{bmatrix}$, $\begin{bmatrix} 2 \\ 0 \\ 2 \end{bmatrix}$, $\begin{bmatrix} 3 \\ 0 \\ 3 \end{bmatrix}$, and $\begin{bmatrix} -5 \\ 1 \\ -5 \end{bmatrix}$ exactly when the vector equation

$$x_1 \begin{bmatrix} 1 \\ 0 \\ 1 \end{bmatrix} + x_2 \begin{bmatrix} 2 \\ 0 \\ 2 \end{bmatrix} + x_3 \begin{bmatrix} 3 \\ 0 \\ 3 \end{bmatrix} + x_4 \begin{bmatrix} -5 \\ 1 \\ -5 \end{bmatrix} = \begin{bmatrix} -13 \\ 3 \\ -15 \end{bmatrix}$$

has a solution. To solve this vector equation, we compute

$$\text{RREF} \left[\begin{array}{cccc|c} 1 & 2 & 3 & -5 & -13 \\ 0 & 0 & 0 & 1 & 3 \\ 1 & 2 & 3 & -5 & -15 \end{array} \right] = \left[\begin{array}{cccc|c} 1 & 2 & 3 & 0 & 0 \\ 0 & 0 & 0 & 1 & 0 \\ 0 & 0 & 0 & 0 & 1 \end{array} \right].$$

This vector equation has no solution, so $\begin{bmatrix} -13 \\ 3 \\ -15 \end{bmatrix}$ is not a linear combination. □

- Write a statement involving the solutions of a vector equation that's equivalent to each claim below.

- The set of vectors $\left\{ \begin{bmatrix} 1 \\ -1 \\ 2 \\ 0 \end{bmatrix}, \begin{bmatrix} 3 \\ -2 \\ 3 \\ 3 \end{bmatrix}, \begin{bmatrix} 10 \\ -7 \\ 11 \\ 9 \end{bmatrix}, \begin{bmatrix} -6 \\ 3 \\ -3 \\ -9 \end{bmatrix} \right\}$ spans \mathbb{R}^4 .

- The set of vectors $\left\{ \begin{bmatrix} 1 \\ -1 \\ 2 \\ 0 \end{bmatrix}, \begin{bmatrix} 3 \\ -2 \\ 3 \\ 3 \end{bmatrix}, \begin{bmatrix} 10 \\ -7 \\ 11 \\ 9 \end{bmatrix}, \begin{bmatrix} -6 \\ 3 \\ -3 \\ -9 \end{bmatrix} \right\}$ does *not* span \mathbb{R}^4 .

- Explain how to determine which of these statements is true.

Solution. The set of vectors $\left\{ \begin{bmatrix} 1 \\ -1 \\ 2 \\ 0 \end{bmatrix}, \begin{bmatrix} 3 \\ -2 \\ 3 \\ 3 \end{bmatrix}, \begin{bmatrix} 10 \\ -7 \\ 11 \\ 9 \end{bmatrix}, \begin{bmatrix} -6 \\ 3 \\ -3 \\ -9 \end{bmatrix} \right\}$ spans \mathbb{R}^4 exactly

when the vector equation

$$x_1 \begin{bmatrix} 1 \\ -1 \\ 2 \\ 0 \end{bmatrix} + x_2 \begin{bmatrix} 3 \\ -2 \\ 3 \\ 3 \end{bmatrix} + x_3 \begin{bmatrix} 10 \\ -7 \\ 11 \\ 9 \end{bmatrix} + x_4 \begin{bmatrix} -6 \\ 3 \\ -3 \\ -9 \end{bmatrix} = \vec{v}$$

has a solution *for all* $\vec{v} \in \mathbb{R}^4$. If there is *some* vector $\vec{v} \in \mathbb{R}^4$ for which this vector equation has no solution, then the set does not span \mathbb{R}^4 . To answer this, we compute

$$\text{RREF} \begin{bmatrix} 1 & 3 & 10 & -6 \\ -1 & -2 & -7 & 3 \\ 2 & 3 & 11 & -3 \\ 0 & 3 & 9 & -9 \end{bmatrix} = \begin{bmatrix} 1 & 0 & 1 & 3 \\ 0 & 1 & 3 & -3 \\ 0 & 0 & 0 & 0 \\ 0 & 0 & 0 & 0 \end{bmatrix}.$$

We see that for some $\vec{v} \in \mathbb{R}^4$, this vector equation will not have a solution, so the set of

vectors $\left\{ \begin{bmatrix} 1 \\ -1 \\ 2 \\ 0 \end{bmatrix}, \begin{bmatrix} 3 \\ -2 \\ 3 \\ 3 \end{bmatrix}, \begin{bmatrix} 10 \\ -7 \\ 11 \\ 9 \end{bmatrix}, \begin{bmatrix} -6 \\ 3 \\ -3 \\ -9 \end{bmatrix} \right\}$ does *not* span \mathbb{R}^4 . □

Consider the following two sets of Euclidean vectors.

$$W = \left\{ \left[\begin{array}{c} x \\ y \\ z \\ w \end{array} \right] \mid x + y = 3z + 2w \right\} \quad U = \left\{ \left[\begin{array}{c} x \\ y \\ z \\ w \end{array} \right] \mid x + y = 3z + w^2 \right\}$$

Explain why one of these sets is a subspace of \mathbb{R}^3 , and why the other is not.

Solution. To show that W is a subspace, first note that it is nonempty as $\begin{bmatrix} 0 \\ 0 \\ 0 \\ 0 \end{bmatrix} \in W$,

since $0 + 0 = 3(0) + 2(0)$. Then let $\vec{v} = \begin{bmatrix} x_1 \\ y_1 \\ z_1 \\ w_1 \end{bmatrix} \in W$ and $\vec{w} = \begin{bmatrix} x_2 \\ y_2 \\ z_2 \\ w_2 \end{bmatrix} \in W$, so we know

that $x_1 + y_1 = 3z_1 + 2w_1$ and $x_2 + y_2 = 3z_2 + 2w_2$.

Consider

$$\begin{bmatrix} x_1 \\ y_1 \\ z_1 \\ w_1 \end{bmatrix} + \begin{bmatrix} x_2 \\ y_2 \\ z_2 \\ w_2 \end{bmatrix} = \begin{bmatrix} x_1 + x_2 \\ y_1 + y_2 \\ z_1 + z_2 \\ w_1 + w_2 \end{bmatrix}.$$

To see if $\vec{v} + \vec{w} \in W$, we need to check if $(x_1 + x_2) + (y_1 + y_2) = 3(z_1 + z_2) + 2(w_1 + w_2)$. We compute

$$\begin{aligned} (x_1 + x_2) + (y_1 + y_2) &= (x_1 + y_1) + (x_2 + y_2) && \text{by regrouping} \\ &= (3z_1 + 2w_1) + (3z_2 + 2w_2) && \text{since} \\ &= 3(z_1 + z_2) + 2(w_1 + w_2) && \text{by regrouping.} \end{aligned}$$

Thus $\vec{v} + \vec{w} \in W$, so W is closed under vector addition.

Now consider

$$c\vec{v} = \begin{bmatrix} cx_1 \\ cy_1 \\ cz_1 \\ cw_1 \end{bmatrix}.$$

Similarly, to check that $c\vec{v} \in W$, we need to check if $cx_1 + cy_1 = 3(cz_1) + 2(cw_1)$, so we compute

$$\begin{aligned} cx_1 + cy_1 &= c(x_1 + y_1) && \text{by factoring} \\ &= c(3z_1 + 2w_1) && \text{since} \\ &= 3(cz_1) + 2(cw_1) && \text{by regrouping} \end{aligned}$$

and we see that $c\vec{v} \in W$, so W is closed under scalar multiplication. Therefore W is a subspace of \mathbb{R}^3 .

Now, to show U is not a subspace, we will show that it is not closed under vector addition.

- (Solution Method 1) Now let $\vec{v} = \begin{bmatrix} x_1 \\ y_1 \\ z_1 \\ w_1 \end{bmatrix} \in U$ and $\vec{w} = \begin{bmatrix} x_2 \\ y_2 \\ z_2 \\ w_2 \end{bmatrix} \in U$, so we know that $x_1 + y_1 = 3z_1 + w_1^2$ and $x_2 + y_2 = 3z_2 + w_2^2$.

Consider

$$\vec{v} + \vec{w} = \begin{bmatrix} x_1 \\ y_1 \\ z_1 \\ w_1 \end{bmatrix} + \begin{bmatrix} x_2 \\ y_2 \\ z_2 \\ w_2 \end{bmatrix} = \begin{bmatrix} x_1 + x_2 \\ y_1 + y_2 \\ z_1 + z_2 \\ w_1 + w_2 \end{bmatrix}.$$

To see if $\vec{v} + \vec{w} \in U$, we need to check if $(x_1 + x_2) + (y_1 + y_2) = 3(z_1 + z_2) + (w_1 + w_2)^2$. We compute

$$\begin{aligned} (x_1 + x_2) + (y_1 + y_2) &= (x_1 + y_1) + (x_2 + y_2) && \text{by regrouping} \\ &= (3z_1 + w_1^2) + (3z_2 + w_2^2) && \text{since} \\ &= 3(z_1 + z_2) + (w_1^2 + w_2^2) && \text{by regrouping} \end{aligned}$$

and thus $\vec{v} + \vec{w} \in U$ \textbf{only when} $w_1^2 + w_2^2 = (w_1 + w_2)^2$. Since this is not true in general, U is not closed under vector addition, and thus cannot be a subspace.

- (Solution Method 2) Note that the vector $\vec{v} = \begin{bmatrix} 0 \\ 1 \\ 0 \\ 1 \end{bmatrix}$ belongs to U since $0+1 = 3(0)+1^2$.

However, the vector $2\vec{v} = \begin{bmatrix} 0 \\ 2 \\ 0 \\ 2 \end{bmatrix}$ does not belong to U since $0+2 \neq 3(0)+2^2$. Therefore

U is not closed under scalar multiplication, and thus is not a subspace.

□

1. Write a statement involving the solutions of a vector equation that's equivalent to each claim below.

- The set of vectors $\left\{ \begin{bmatrix} 1 \\ 3 \\ 4 \\ -4 \end{bmatrix}, \begin{bmatrix} -1 \\ -3 \\ -4 \\ 4 \end{bmatrix}, \begin{bmatrix} 0 \\ 1 \\ 3 \\ -3 \end{bmatrix} \right\}$ is linearly *independent*.
- The set of vectors $\left\{ \begin{bmatrix} 1 \\ 3 \\ 4 \\ -4 \end{bmatrix}, \begin{bmatrix} -1 \\ -3 \\ -4 \\ 4 \end{bmatrix}, \begin{bmatrix} 0 \\ 1 \\ 3 \\ -3 \end{bmatrix} \right\}$ is linearly *dependent*.

2. Explain how to determine which of these statements is true.

Solution. The set of vectors $\left\{ \begin{bmatrix} 1 \\ 3 \\ 4 \\ -4 \end{bmatrix}, \begin{bmatrix} -1 \\ -3 \\ -4 \\ 4 \end{bmatrix}, \begin{bmatrix} 0 \\ 1 \\ 3 \\ -3 \end{bmatrix} \right\}$ is linearly independent exactly

when the vector equation

$$x_1 \begin{bmatrix} 1 \\ 3 \\ 4 \\ -4 \end{bmatrix} + x_2 \begin{bmatrix} -1 \\ -3 \\ -4 \\ 4 \end{bmatrix} + x_3 \begin{bmatrix} 0 \\ 1 \\ 3 \\ -3 \end{bmatrix} = \begin{bmatrix} 0 \\ 0 \\ 0 \\ 0 \end{bmatrix}$$

has no non-trivial (i.e. nonzero) solutions. The set is linearly *dependent* when there exists a nontrivial (i.e. nonzero) solution. We compute

$$\text{RREF} \begin{bmatrix} 1 & -1 & 0 \\ 3 & -3 & 1 \\ 4 & -4 & 3 \\ -4 & 4 & -3 \end{bmatrix} = \begin{bmatrix} 1 & -1 & 0 \\ 0 & 0 & 1 \\ 0 & 0 & 0 \\ 0 & 0 & 0 \end{bmatrix}.$$

Thus, this vector equation has a solution set $\left\{ \begin{bmatrix} a \\ a \\ 0 \end{bmatrix} \mid a \in \mathbb{R} \right\}$. Since there are nontrivial solutions, we conclude that the set of vectors $\left\{ \begin{bmatrix} 1 \\ 3 \\ 4 \\ -4 \end{bmatrix}, \begin{bmatrix} -1 \\ -3 \\ -4 \\ 4 \end{bmatrix}, \begin{bmatrix} 0 \\ 1 \\ 3 \\ -3 \end{bmatrix} \right\}$ is linearly *dependent*. \square

- Write a statement involving spanning and independence properties that's equivalent to each claim below.

• The set of vectors $\left\{ \begin{bmatrix} 1 \\ 3 \\ 4 \\ -4 \end{bmatrix}, \begin{bmatrix} 0 \\ 1 \\ 3 \\ -3 \end{bmatrix}, \begin{bmatrix} 3 \\ 11 \\ 18 \\ -18 \end{bmatrix}, \begin{bmatrix} -2 \\ -7 \\ -11 \\ 11 \end{bmatrix} \right\}$ is a *basis* of \mathbb{R}^4 .

• The set of vectors $\left\{ \begin{bmatrix} 1 \\ 3 \\ 4 \\ -4 \end{bmatrix}, \begin{bmatrix} 0 \\ 1 \\ 3 \\ -3 \end{bmatrix}, \begin{bmatrix} 3 \\ 11 \\ 18 \\ -18 \end{bmatrix}, \begin{bmatrix} -2 \\ -7 \\ -11 \\ 11 \end{bmatrix} \right\}$ is *not* a basis of \mathbb{R}^4 .

- Explain how to determine which of these statements is true.

Solution. The set of vectors $\left\{ \begin{bmatrix} 1 \\ 3 \\ 4 \\ -4 \end{bmatrix}, \begin{bmatrix} 0 \\ 1 \\ 3 \\ -3 \end{bmatrix}, \begin{bmatrix} 3 \\ 11 \\ 18 \\ -18 \end{bmatrix}, \begin{bmatrix} -2 \\ -7 \\ -11 \\ 11 \end{bmatrix} \right\}$ is a basis of \mathbb{R}^4

exactly when it is linearly independent *and* the set spans \mathbb{R}^4 . If it is either linearly dependent, *or* the set does not span \mathbb{R}^4 , then the set is not a basis.

To answer this, we compute

$$\text{RREF} \begin{bmatrix} 1 & 0 & 3 & -2 \\ 3 & 1 & 11 & -7 \\ 4 & 3 & 18 & -11 \\ -4 & -3 & -18 & 11 \end{bmatrix} = \begin{bmatrix} 1 & 0 & 3 & -2 \\ 0 & 1 & 2 & -1 \\ 0 & 0 & 0 & 0 \\ 0 & 0 & 0 & 0 \end{bmatrix}.$$

We see that this set of vectors is linearly dependent, so therefore the set of vectors $\left\{ \begin{bmatrix} 1 \\ 3 \\ 4 \\ -4 \end{bmatrix}, \begin{bmatrix} 0 \\ 1 \\ 3 \\ -3 \end{bmatrix}, \begin{bmatrix} 3 \\ 11 \\ 18 \\ -18 \end{bmatrix}, \begin{bmatrix} -2 \\ -7 \\ -11 \\ 11 \end{bmatrix} \right\}$ is *not* a basis. \square

Consider the subspace

$$W = \text{span} \left\{ \begin{bmatrix} 1 \\ -3 \\ -1 \\ 2 \end{bmatrix}, \begin{bmatrix} 1 \\ 0 \\ 1 \\ -2 \end{bmatrix}, \begin{bmatrix} 3 \\ -6 \\ -1 \\ 2 \end{bmatrix}, \begin{bmatrix} 1 \\ 6 \\ 1 \\ -1 \end{bmatrix}, \begin{bmatrix} 2 \\ 3 \\ 0 \\ 1 \end{bmatrix} \right\}.$$

1. Explain how to find a basis of W .
2. Explain how to find the dimension of W .

Solution.

1. Observe that

$$\text{RREF} \begin{bmatrix} 1 & 1 & 3 & 1 & 2 \\ -3 & 0 & -6 & 6 & 3 \\ -1 & 1 & -1 & 1 & 0 \\ 2 & -2 & 2 & -1 & 1 \end{bmatrix} = \begin{bmatrix} 1 & 0 & 2 & 0 & 1 \\ 0 & 1 & 1 & 0 & 0 \\ 0 & 0 & 0 & 1 & 1 \\ 0 & 0 & 0 & 0 & 0 \end{bmatrix}$$

If we remove the vectors yielding non-pivot columns, the resulting set will span the same vectors while being linearly independent. Therefore

$$\left\{ \begin{bmatrix} 1 \\ -3 \\ -1 \\ 2 \end{bmatrix}, \begin{bmatrix} 1 \\ 0 \\ 1 \\ -2 \end{bmatrix}, \begin{bmatrix} 1 \\ 6 \\ 1 \\ -1 \end{bmatrix} \right\}$$

is a basis of W .

2. Since this (and thus every other) basis has three vectors in it, the dimension of W is 3.

\square

Consider the homogeneous system of equations

$$\begin{aligned}x_1 + x_2 + 3x_3 + x_4 + 2x_5 &= 0 \\-3x_1 - 6x_3 + 6x_4 + 3x_5 &= 0 \\-x_1 + x_2 - x_3 + x_4 &= 0 \\2x_1 - 2x_2 + 2x_3 - x_4 + x_5 &= 0\end{aligned}$$

1. Find the solution space of the system.
2. Find a basis of the solution space.

Solution.

1. Observe that

$$\text{RREF} \left[\begin{array}{ccccc|c} 1 & 1 & 3 & 1 & 2 & 0 \\ -3 & 0 & -6 & 6 & 3 & 0 \\ -1 & 1 & -1 & 1 & 0 & 0 \\ 2 & -2 & 2 & -1 & 1 & 0 \end{array} \right] = \left[\begin{array}{ccccc|c} 1 & 0 & 2 & 0 & 1 & 0 \\ 0 & 1 & 1 & 0 & 0 & 0 \\ 0 & 0 & 0 & 1 & 1 & 0 \\ 0 & 0 & 0 & 0 & 0 & 0 \end{array} \right]$$

Letting $x_3 = a$ and $x_5 = b$ (since those correspond to the non-pivot columns), this is equivalent to the system

$$\begin{aligned}x_1 + 2x_3 + x_5 &= 0 \\x_2 + x_3 &= 0 \\x_3 &= a \\x_4 + x_5 &= 0 \\x_5 &= b\end{aligned}$$

Thus, the solution set is

$$\left\{ \left[\begin{array}{c} -2a - b \\ -a \\ a \\ -b \\ b \end{array} \right] \mid a, b \in \mathbb{R} \right\}.$$

2. Since we can write

$$\left[\begin{array}{c} -2a - b \\ -a \\ a \\ -b \\ b \end{array} \right] = a \left[\begin{array}{c} -2 \\ -1 \\ 1 \\ 0 \\ 0 \end{array} \right] + b \left[\begin{array}{c} -1 \\ 0 \\ 0 \\ -1 \\ 1 \end{array} \right],$$

a basis for the solution space is

$$\left\{ \left[\begin{array}{c} -2 \\ -1 \\ 1 \\ 0 \\ 0 \end{array} \right], \left[\begin{array}{c} -1 \\ 0 \\ 0 \\ -1 \\ 1 \end{array} \right] \right\}.$$

□

Answer the following questions about transformations.

1. Consider the following maps of Euclidean vectors $P : \mathbb{R}^3 \rightarrow \mathbb{R}^3$ and $Q : \mathbb{R}^3 \rightarrow \mathbb{R}^3$ defined by

$$P \left(\begin{bmatrix} x \\ y \\ z \end{bmatrix} \right) = \begin{bmatrix} 3x - y + z \\ 2x - 2y + 4z \\ -2x - 2y - 3z \end{bmatrix} \quad \text{and} \quad Q \left(\begin{bmatrix} x \\ y \\ z \end{bmatrix} \right) = \begin{bmatrix} y - 2z \\ -3x - 4y + 12z \\ 5xy + 3z \end{bmatrix}.$$

Without writing a proof, explain why only one of these maps is likely to be a linear transformation.

2. Consider the following map of Euclidean vectors $S : \mathbb{R}^2 \rightarrow \mathbb{R}^2$

$$S \left(\begin{bmatrix} x \\ y \end{bmatrix} \right) = \begin{bmatrix} x + 2y \\ -3xy \end{bmatrix}.$$

Prove that S is *not* a linear transformation.

3. Consider the following map of Euclidean vectors $T : \mathbb{R}^2 \rightarrow \mathbb{R}^2$

$$T \left(\begin{bmatrix} x \\ y \end{bmatrix} \right) = \begin{bmatrix} -4x - 5y \\ 2x - 4y \end{bmatrix}.$$

Prove that T is a linear transformation.

Solution.

1. A linear map between Euclidean spaces must consist of linear polynomials in each component. All three components of P are linear so P is likely to be linear; however, the third component of Q contains the nonlinear term xy , so Q is unlikely to be linear.
2. We need to show *either* that S fails to preserve either vector addition *or* that S fails to preserve scalar multiplication.

For example, for a scalar $c \in \mathbb{R}$ and a vector $\begin{bmatrix} x \\ y \end{bmatrix} \in \mathbb{R}^2$, we can compute

$$S \left(c \begin{bmatrix} x \\ y \end{bmatrix} \right) = S \left(\begin{bmatrix} cx \\ cy \end{bmatrix} \right) = \begin{bmatrix} cx + 2cy \\ -3c^2xy \end{bmatrix}$$

whereas

$$cS \left(\begin{bmatrix} x \\ y \end{bmatrix} \right) = c \begin{bmatrix} x + 2y \\ -3xy \end{bmatrix} = \begin{bmatrix} cx + 2cy \\ -3cxy \end{bmatrix}.$$

Since $-3c^2xy \neq -3cxy$, we see that $S \left(c \begin{bmatrix} x \\ y \end{bmatrix} \right) \neq cS \left(\begin{bmatrix} x \\ y \end{bmatrix} \right)$, so S fails to preserve scalar multiplication and cannot be a linear transformation.

Alternatively, we could instead take two vectors $\begin{bmatrix} x_1 \\ y_1 \end{bmatrix}, \begin{bmatrix} x_2 \\ y_2 \end{bmatrix} \in \mathbb{R}^2$ and compute

$$S\left(\begin{bmatrix} x_1 \\ y_1 \end{bmatrix} + \begin{bmatrix} x_2 \\ y_2 \end{bmatrix}\right) = S\left(\begin{bmatrix} x_1 + x_2 \\ y_1 + y_2 \end{bmatrix}\right) = \begin{bmatrix} (x_1 + x_2) + 2(y_1 + y_2) \\ -3(x_1 + x_2)(y_1 + y_2) \end{bmatrix}$$

whereas

$$S\left(\begin{bmatrix} x_1 \\ y_1 \end{bmatrix}\right) + S\left(\begin{bmatrix} x_2 \\ y_2 \end{bmatrix}\right) = \begin{bmatrix} x_1 + 2y_1 \\ -3x_1y_1 \end{bmatrix} + \begin{bmatrix} x_2 + 2y_2 \\ -3x_2y_2 \end{bmatrix} = \begin{bmatrix} x_1 + 2y_1 + x_2 + 2y_2 \\ -3x_1y_1 - 3x_2y_2 \end{bmatrix}$$

Since $-3(x_1 + x_2)(y_1 + y_2) \neq -3x_1y_1 - 3x_2y_2$, we see that $S\left(\begin{bmatrix} x_1 \\ y_1 \end{bmatrix} + \begin{bmatrix} x_2 \\ y_2 \end{bmatrix}\right) \neq S\left(\begin{bmatrix} x_1 \\ y_1 \end{bmatrix}\right) + S\left(\begin{bmatrix} x_2 \\ y_2 \end{bmatrix}\right)$, so S fails to preserve addition and cannot be a linear transformation.

3. We need to show that T preserves *both* vector addition *and* that T preserves scalar multiplication.

First, let us take two vectors $\begin{bmatrix} x_1 \\ y_1 \end{bmatrix}, \begin{bmatrix} x_2 \\ y_2 \end{bmatrix} \in \mathbb{R}^2$ and compute

$$T\left(\begin{bmatrix} x_1 \\ y_1 \end{bmatrix} + \begin{bmatrix} x_2 \\ y_2 \end{bmatrix}\right) = T\left(\begin{bmatrix} x_1 + x_2 \\ y_1 + y_2 \end{bmatrix}\right) = \begin{bmatrix} -4(x_1 + x_2) - 5(y_1 + y_2) \\ 2(x_1 + x_2) - 4(y_1 + y_2) \end{bmatrix}$$

and

$$T\left(\begin{bmatrix} x_1 \\ y_1 \end{bmatrix}\right) + T\left(\begin{bmatrix} x_2 \\ y_2 \end{bmatrix}\right) = \begin{bmatrix} -4x_1 - 5y_1 \\ 2x_1 - 4y_1 \end{bmatrix} + \begin{bmatrix} -4x_2 - 5y_2 \\ 2x_2 - 4y_2 \end{bmatrix} = \begin{bmatrix} -4x_1 - 5y_1 - 4x_2 - 5y_2 \\ 2x_1 - 4y_1 + 2x_2 - 4y_2 \end{bmatrix}$$

So we see that $T\left(\begin{bmatrix} x_1 \\ y_1 \end{bmatrix} + \begin{bmatrix} x_2 \\ y_2 \end{bmatrix}\right) = T\left(\begin{bmatrix} x_1 \\ y_1 \end{bmatrix}\right) + T\left(\begin{bmatrix} x_2 \\ y_2 \end{bmatrix}\right)$, so T preserves addition.

Now, take a scalar $c \in \mathbb{R}$ and a vector $\begin{bmatrix} x \\ y \end{bmatrix} \in \mathbb{R}^2$, and compute

$$T\left(c \begin{bmatrix} x \\ y \end{bmatrix}\right) = T\left(\begin{bmatrix} cx \\ cy \end{bmatrix}\right) = \begin{bmatrix} -4cx - 5cy \\ 2cx - 4cy \end{bmatrix}$$

and

$$cT\left(\begin{bmatrix} x \\ y \end{bmatrix}\right) = c \begin{bmatrix} -4x - 5y \\ 2x - 4y \end{bmatrix} = \begin{bmatrix} -4cx - 5cy \\ 2cx - 4cy \end{bmatrix}.$$

We see that $T\left(c \begin{bmatrix} x \\ y \end{bmatrix}\right) = cT\left(\begin{bmatrix} x \\ y \end{bmatrix}\right)$, so T preserves scalar multiplication.

Since T preserves both addition and scalar multiplication, we have proven that T is a linear transformation.

□

1. Find the standard matrix for the linear transformation $T : \mathbb{R}^3 \rightarrow \mathbb{R}^4$ given by

$$T \left(\begin{bmatrix} x \\ y \\ z \end{bmatrix} \right) = \begin{bmatrix} -x + y \\ -x + 3y - z \\ 7x + y + 3z \\ 0 \end{bmatrix}.$$

2. Let $S : \mathbb{R}^4 \rightarrow \mathbb{R}^3$ be the linear transformation given by the standard matrix

$$\begin{bmatrix} 2 & 3 & 4 & 1 \\ 0 & 1 & -1 & -1 \\ 3 & -2 & -2 & 4 \end{bmatrix}.$$

Compute $S \left(\begin{bmatrix} -2 \\ 1 \\ 3 \\ 2 \end{bmatrix} \right)$.

Solution.

1. Since

$$T \left(\begin{bmatrix} 1 \\ 0 \\ 0 \end{bmatrix} \right) = \begin{bmatrix} -1 \\ -1 \\ 7 \\ 0 \end{bmatrix}$$

$$T \left(\begin{bmatrix} 0 \\ 1 \\ 0 \end{bmatrix} \right) = \begin{bmatrix} 1 \\ 3 \\ 1 \\ 0 \end{bmatrix}$$

$$T \left(\begin{bmatrix} 0 \\ 0 \\ 1 \end{bmatrix} \right) = \begin{bmatrix} 0 \\ -1 \\ 3 \\ 0 \end{bmatrix},$$

the standard matrix for T is $\begin{bmatrix} -1 & 1 & 0 \\ -1 & 3 & -1 \\ 7 & 1 & 3 \\ 0 & 0 & 0 \end{bmatrix}$.

- 2.

$$\begin{aligned} S \left(\begin{bmatrix} -2 \\ 1 \\ 3 \\ 2 \end{bmatrix} \right) &= -2S(\vec{e}_1) + S(\vec{e}_2) + 3S(\vec{e}_3) + 2S(\vec{e}_4) \\ &= -2 \begin{bmatrix} 2 \\ 0 \\ 3 \end{bmatrix} + \begin{bmatrix} 3 \\ 1 \\ -2 \end{bmatrix} + 3 \begin{bmatrix} 4 \\ -1 \\ -2 \end{bmatrix} + 2 \begin{bmatrix} 1 \\ -1 \\ 4 \end{bmatrix} = \begin{bmatrix} 13 \\ -4 \\ -6 \end{bmatrix}. \end{aligned}$$

□

Let $T : \mathbb{R}^4 \rightarrow \mathbb{R}^3$ be the linear transformation given by

$$T \left(\begin{bmatrix} x \\ y \\ z \\ w \end{bmatrix} \right) = \begin{bmatrix} x + 3y + 2z - 3w \\ 2x + 4y + 6z - 10w \\ x + 6y - z + 3w \end{bmatrix}$$

1. Explain how to find the image of T and the kernel of T .
2. Explain how to find a basis of the image of T and a basis of the kernel of T .
3. Explain how to find the rank and nullity of T , and why the rank-nullity theorem holds for T .

Solution.

1. To find the image we compute

$$\begin{aligned} \text{Im}(T) &= T(\text{span}\{\vec{e}_1, \vec{e}_2, \vec{e}_3, \vec{e}_4\}) \\ &= \text{span}\{T(\vec{e}_1), T(\vec{e}_2), T(\vec{e}_3), T(\vec{e}_4)\} \\ &= \text{span}\left\{ \begin{bmatrix} 1 \\ 2 \\ 1 \end{bmatrix}, \begin{bmatrix} 3 \\ 4 \\ 6 \end{bmatrix}, \begin{bmatrix} 2 \\ 6 \\ -1 \end{bmatrix}, \begin{bmatrix} -3 \\ -10 \\ 3 \end{bmatrix} \right\}. \end{aligned}$$

2. The kernel is the solution set of the corresponding homogeneous system of equations, i.e.

$$\begin{aligned} x + 3y + 2z - 3w &= 0 \\ 2x + 4y + 6z - 10w &= 0 \\ x + 6y - z + 3w &= 0. \end{aligned}$$

So we compute

$$\text{RREF} \left[\begin{array}{cccc|c} 1 & 3 & 2 & -3 & 0 \\ 2 & 4 & 6 & -10 & 0 \\ 1 & 6 & -1 & 3 & 0 \end{array} \right] = \left[\begin{array}{cccc|c} 1 & 0 & 5 & -9 & 0 \\ 0 & 1 & -1 & 2 & 0 \\ 0 & 0 & 0 & 0 & 0 \end{array} \right].$$

Then, letting $z = a$ and $w = b$ we have

$$\ker T = \left\{ \left[\begin{array}{c} -5a + 9b \\ a - 2b \\ a \\ b \end{array} \right] \mid a, b \in \mathbb{R} \right\}.$$

3. Since $\text{Im}(T) = \text{span} \left\{ \begin{bmatrix} 1 \\ 2 \\ 1 \end{bmatrix}, \begin{bmatrix} 3 \\ 4 \\ 6 \end{bmatrix}, \begin{bmatrix} 2 \\ 6 \\ -1 \end{bmatrix}, \begin{bmatrix} -3 \\ -10 \\ 3 \end{bmatrix} \right\}$, we simply need to find a linearly independent subset of these four spanning vectors. So we compute

$$\text{RREF} \begin{bmatrix} 1 & 3 & 2 & -3 \\ 2 & 4 & 6 & -10 \\ 1 & 6 & -1 & 3 \end{bmatrix} = \begin{bmatrix} 1 & 0 & 5 & -9 \\ 0 & 1 & -1 & 2 \\ 0 & 0 & 0 & 0 \end{bmatrix}.$$

Since the first two columns are pivot columns, they form a linearly independent spanning set, so a basis for $\text{Im } T$ is $\left\{ \begin{bmatrix} 1 \\ 2 \\ 1 \end{bmatrix}, \begin{bmatrix} 3 \\ 4 \\ 6 \end{bmatrix} \right\}$.

To find a basis for the kernel, note that

$$\begin{aligned} \ker T &= \left\{ \begin{bmatrix} -5a + 9b \\ a - 2b \\ a \\ b \end{bmatrix} \mid a, b \in \mathbb{R} \right\} \\ &= \left\{ a \begin{bmatrix} -5 \\ 1 \\ 1 \\ 0 \end{bmatrix} + b \begin{bmatrix} 9 \\ -2 \\ 0 \\ 1 \end{bmatrix} \mid a, b \in \mathbb{R} \right\} \\ &= \text{span} \left\{ \begin{bmatrix} -5 \\ 1 \\ 1 \\ 0 \end{bmatrix}, \begin{bmatrix} 9 \\ -2 \\ 0 \\ 1 \end{bmatrix} \right\}. \end{aligned}$$

so a basis for the kernel is

$$\left\{ \begin{bmatrix} -5 \\ 1 \\ 1 \\ 0 \end{bmatrix}, \begin{bmatrix} 9 \\ -2 \\ 0 \\ 1 \end{bmatrix} \right\}.$$

4. The dimension of the image (the rank) is 2, the dimension of the kernel (the nullity) is 2, and the dimension of the domain of T is 4, so we see $2 + 2 = 4$, which verifies that the sum of the rank and nullity of T is the dimension of the domain of T .

□

Let $T : \mathbb{R}^4 \rightarrow \mathbb{R}^3$ be the linear transformation given by the standard matrix

$$\begin{bmatrix} 1 & 3 & 2 & -3 \\ 2 & 4 & 6 & -10 \\ 1 & 6 & -1 & 3 \end{bmatrix}.$$

1. Explain why T is or is not injective.

2. Explain why T is or is not surjective.

Solution. Compute

$$\text{RREF} \begin{bmatrix} 1 & 3 & 2 & -3 \\ 2 & 4 & 6 & -10 \\ 1 & 6 & -1 & 3 \end{bmatrix} = \begin{bmatrix} 1 & 0 & 5 & -9 \\ 0 & 1 & -1 & 2 \\ 0 & 0 & 0 & 0 \end{bmatrix}.$$

1. Note that the third and fourth columns are non-pivot columns, which means $\ker T$ contains infinitely many vectors, so T is not injective.
2. Since there are only two pivots, the image (i.e. the span of the columns) is a 2-dimensional subspace (and thus does not equal \mathbb{R}^3), so T is not surjective.

□

Let V be the set of all pairs of numbers (x, y) of real numbers together with the following operations:

$$\begin{aligned} (x_1, y_1) \oplus (x_2, y_2) &= (2x_1 + 2x_2, 2y_1 + 2y_2) \\ c \odot (x, y) &= (cx, c^2y) \end{aligned}$$

1. Show that scalar multiplication distributes over vector addition:

$$c \odot ((x_1, y_1) \oplus (x_2, y_2)) = c \odot (x_1, y_1) \oplus c \odot (x_2, y_2)$$

2. Explain why V nonetheless is not a vector space.

Solution.

1. We compute both sides:

$$\begin{aligned} c \odot ((x_1, y_1) \oplus (x_2, y_2)) &= c \odot (2x_1 + 2x_2, 2y_1 + 2y_2) \\ &= (c(2x_1 + 2x_2), c^2(2y_1 + 2y_2)) \\ &= (2cx_1 + 2cx_2, 2c^2y_1 + 2c^2y_2) \end{aligned}$$

and

$$\begin{aligned} c \odot (x_1, y_1) \oplus c \odot (x_2, y_2) &= (cx_1, c^2y_1) \oplus (cx_2, c^2y_2) \\ &= (2cx_1 + 2cx_2, 2c^2y_1 + 2c^2y_2) \end{aligned}$$

Since these are the same, we have shown that the property holds.

2. To show V is not a vector space, we must show that it fails one of the 8 defining properties of vector spaces. We will show that scalar multiplication does not distribute over scalar addition, i.e., there are values such that

$$(c + d) \odot (x, y) \neq c \odot (x, y) \oplus d \odot (x, y)$$

- (Solution method 1) First, we compute

$$\begin{aligned}(c + d) \odot (x, y) &= ((c + d)x, (c + d)^2y) \\ &= ((c + d)x, (c^2 + 2cd + d^2)y).\end{aligned}$$

Then we compute

$$\begin{aligned}c \odot (x, y) \oplus d \odot (x, y) &= (cx, c^2y) \oplus (dx, d^2y) \\ &= (2cx + 2dx, 2c^2y + 2d^2y).\end{aligned}$$

Since $(c + d)x \neq 2cx + 2dx$ when $c, d, x, y = 1$, the property fails to hold.

- (Solution method 2) When we let $c, d, x, y = 1$, we may simplify both sides as follows.

$$\begin{aligned}(c + d) \odot (x, y) &= 2 \odot (1, 1) \\ &= (2 \cdot 1, 2^2 \cdot 1) \\ &= (2, 4)\end{aligned}$$

$$\begin{aligned}c \odot (x, y) \oplus d \odot (x, y) &= 1 \odot (1, 1) \oplus 1 \odot (1, 1) \\ &= (1 \cdot 1, 1^2 \cdot 1) \oplus (1 \cdot 1, 1^2 \cdot 1) \\ &= (1, 1) \oplus (1, 1) \\ &= (2 \cdot 1 + 2 \cdot 1, 2 \cdot 1 + 2 \cdot 1) \\ &= (4, 4)\end{aligned}$$

Since these ordered pairs are different, the property fails to hold.

□

1. Given the set

$$\{x^3 - 2x^2 + x + 2, 2x^2 - 1, -x^3 + 3x^2 + 3x - 2, x^3 - 6x^2 + 9x + 5\}$$

write a statement involving the solutions to a polynomial equation that's equivalent to each claim below.

- The set of polynomials is linearly *independent*.
- The set of polynomials is linearly *dependent*.

2. Explain how to determine which of these statements is true.

Solution. The set of polynomials

$$\{x^3 - 2x^2 + x + 2, 2x^2 - 1, -x^3 + 3x^2 + 3x - 2, x^3 - 6x^2 + 9x + 5\}$$

is linearly *independent* exactly when the polynomial equation

$$y_1(x^3 - 2x^2 + x + 2) + y_2(2x^2 - 1) + y_3(-x^3 + 3x^2 + 3x - 2) + y_4(x^3 - 6x^2 + 9x + 5) = 0$$

has no nontrivial (i.e. nonzero) solutions. The set is linearly *dependent* when this equation has a nontrivial (i.e. nonzero) solution.

To solve this equation, we distribute and then collect coefficients to obtain

$$(y_1 - y_3 + y_4)x^3 + (-2y_1 + 2y_2 + 3y_3 - 6y_4)x^2 + (y_1 + 3y_3 + 9y_4)x + (2y_1 - y_2 - 2y_3 + 5y_4) = 0.$$

These polynomials are equal precisely when their coefficients are equal, leading to the system

$$\begin{array}{rccccrcr} y_1 & & & - & y_3 & + & y_4 & = & 0 \\ -2y_1 & + & 2y_2 & + & 3y_3 & - & 6y_4 & = & 0 \\ y_1 & + & & + & 3y_3 & + & 9y_4 & = & 0 \\ 2y_1 & - & y_2 & - & 2y_3 & + & 5y_4 & = & 0 \end{array}$$

To solve this, we compute

$$\text{RREF} \left[\begin{array}{cccc|c} 1 & 0 & -1 & 1 & 0 \\ -2 & 2 & 3 & -6 & 0 \\ 1 & 0 & 3 & 9 & 0 \\ 2 & -1 & -2 & 5 & 0 \end{array} \right] = \left[\begin{array}{cccc|c} 1 & 0 & 0 & 3 & 0 \\ 0 & 1 & 0 & -3 & 0 \\ 0 & 0 & 1 & 2 & 0 \\ 0 & 0 & 0 & 0 & 0 \end{array} \right]$$

The system has (infinitely many) nontrivial solutions, so we that the set of polynomials is linearly *dependent*. \square

Of the following three matrices, only two may be multiplied.

$$A = \begin{bmatrix} 1 & -3 \\ 0 & 1 \end{bmatrix} \quad B = [4 \quad 1 \quad 2] \quad C = \begin{bmatrix} 0 & 1 & 3 \\ 1 & -2 & 5 \end{bmatrix}$$

Explain which two may be multiplied and why. Then show how to find their product.

Solution. AC is the only one that can be computed, since C corresponds to a linear transformation $\mathbb{R}^3 \rightarrow \mathbb{R}^2$ and A corresponds to a linear transformation $\mathbb{R}^2 \rightarrow \mathbb{R}^2$. Thus the composition AC corresponds to a linear transformation $\mathbb{R}^3 \rightarrow \mathbb{R}^2$ with a 2×3 standard matrix. We compute

$$AC(\vec{e}_1) = A\left(\begin{bmatrix} 0 \\ 1 \end{bmatrix}\right) = 0 \begin{bmatrix} 1 \\ 0 \end{bmatrix} + 1 \begin{bmatrix} -3 \\ 1 \end{bmatrix} = \begin{bmatrix} -3 \\ 1 \end{bmatrix}$$

$$AC(\vec{e}_2) = A\left(\begin{bmatrix} 1 \\ -2 \end{bmatrix}\right) = 1 \begin{bmatrix} 1 \\ 0 \end{bmatrix} - 2 \begin{bmatrix} -3 \\ 1 \end{bmatrix} = \begin{bmatrix} 7 \\ -2 \end{bmatrix}$$

$$AC(\vec{e}_3) = A\left(\begin{bmatrix} 3 \\ 5 \end{bmatrix}\right) = 3 \begin{bmatrix} 1 \\ 0 \end{bmatrix} + 5 \begin{bmatrix} -3 \\ 1 \end{bmatrix} = \begin{bmatrix} -12 \\ 5 \end{bmatrix}$$

Thus

$$AC = \begin{bmatrix} -3 & 7 & -12 \\ 1 & -2 & 5 \end{bmatrix}.$$

\square

Explain why each of the following matrices is or is not invertible by discussing its corresponding linear transformation. If the matrix is invertible, explain how to find its inverse.

$$D = \begin{bmatrix} -1 & 1 & 0 & 2 \\ -2 & 5 & 5 & -4 \\ 2 & -3 & -2 & 0 \\ 4 & -4 & -3 & 5 \end{bmatrix} \quad N = \begin{bmatrix} -3 & 9 & 1 & -11 \\ 3 & -9 & -2 & 13 \\ 3 & -9 & -3 & 15 \\ -4 & 12 & 2 & -16 \end{bmatrix}$$

Solution. We compute

$$\text{RREF}(D) = \begin{bmatrix} 1 & 0 & 0 & 0 \\ 0 & 1 & 0 & 0 \\ 0 & 0 & 1 & 0 \\ 0 & 0 & 0 & 1 \end{bmatrix}.$$

We see D is bijective, and therefore invertible. To compute the inverse, we solve $D\vec{x} = \vec{e}_1$ by computing

$$\text{RREF} \left[\begin{array}{cccc|c} -1 & 1 & 0 & 2 & 1 \\ -2 & 5 & 5 & -4 & 0 \\ 2 & -3 & -2 & 0 & 0 \\ 4 & -4 & -3 & 5 & 0 \end{array} \right] = \left[\begin{array}{cccc|c} 1 & 0 & 0 & 0 & 21 \\ 0 & 1 & 0 & 0 & 38 \\ 0 & 0 & 1 & 0 & -36 \\ 0 & 0 & 0 & 1 & -8 \end{array} \right].$$

Similarly, we solve $D\vec{x} = \vec{e}_2$ by computing

$$\text{RREF} \left[\begin{array}{cccc|c} -1 & 1 & 0 & 2 & 0 \\ -2 & 5 & 5 & -4 & 1 \\ 2 & -3 & -2 & 0 & 0 \\ 4 & -4 & -3 & 5 & 0 \end{array} \right] = \left[\begin{array}{cccc|c} 1 & 0 & 0 & 0 & 8 \\ 0 & 1 & 0 & 0 & 14 \\ 0 & 0 & 1 & 0 & -13 \\ 0 & 0 & 0 & 1 & -3 \end{array} \right].$$

Similarly, we solve $D\vec{x} = \vec{e}_3$ by computing

$$\text{RREF} \left[\begin{array}{cccc|c} -1 & 1 & 0 & 2 & 0 \\ -2 & 5 & 5 & -4 & 0 \\ 2 & -3 & -2 & 0 & 1 \\ 4 & -4 & -3 & 5 & 0 \end{array} \right] = \left[\begin{array}{cccc|c} 1 & 0 & 0 & 0 & 23 \\ 0 & 1 & 0 & 0 & 41 \\ 0 & 0 & 1 & 0 & -39 \\ 0 & 0 & 0 & 1 & -9 \end{array} \right].$$

Similarly, we solve $D\vec{x} = \vec{e}_4$ by computing

$$\text{RREF} \left[\begin{array}{cccc|c} -1 & 1 & 0 & 2 & 0 \\ -2 & 5 & 5 & -4 & 0 \\ 2 & -3 & -2 & 0 & 0 \\ 4 & -4 & -3 & 5 & 1 \end{array} \right] = \left[\begin{array}{cccc|c} 1 & 0 & 0 & 0 & -2 \\ 0 & 1 & 0 & 0 & -4 \\ 0 & 0 & 1 & 0 & 4 \\ 0 & 0 & 0 & 1 & 1 \end{array} \right].$$

Combining these, we obtain

$$D^{-1} = \begin{bmatrix} 21 & 8 & 23 & -2 \\ 38 & 14 & 41 & -4 \\ -36 & -13 & -39 & 4 \\ -8 & -3 & -9 & 1 \end{bmatrix}.$$

We compute

$$\text{RREF}(N) = \begin{bmatrix} 1 & -3 & 0 & 3 \\ 0 & 0 & 1 & -2 \\ 0 & 0 & 0 & 0 \\ 0 & 0 & 0 & 0 \end{bmatrix}.$$

We see N is not bijective and thus is *not* invertible. □

Use a matrix inverse to solve the following matrix-vector equation.

$$\begin{bmatrix} 1 & 2 & 1 \\ 0 & 0 & 2 \\ 1 & 1 & 1 \end{bmatrix} \vec{v} = \begin{bmatrix} 4 \\ -2 \\ 2 \end{bmatrix}$$

Solution. Using the techniques from section [Section 4.3](#), and letting $M = \begin{bmatrix} 1 & 2 & 1 \\ 0 & 0 & 2 \\ 1 & 1 & 1 \end{bmatrix}$, we find $M^{-1} = \begin{bmatrix} -1 & -1/2 & 2 \\ 1 & 0 & -1 \\ 0 & 1/2 & 0 \end{bmatrix}$. Our equation can be written as $M\vec{v} = \begin{bmatrix} 4 \\ -2 \\ 2 \end{bmatrix}$, and may therefore be solved via

$$\vec{v} = I\vec{v} = M^{-1}M\vec{v} = M^{-1} \begin{bmatrix} 4 \\ -2 \\ 2 \end{bmatrix} = \begin{bmatrix} 1 \\ 2 \\ -1 \end{bmatrix}$$

□

Let A be a 4×4 matrix.

1. Give a 4×4 matrix P that may be used to perform the row operation $R_3 \rightarrow R_3 + 4R_1$.
2. Give a 4×4 matrix Q that may be used to perform the row operation $R_1 \rightarrow -4R_1$.
3. Use matrix multiplication to describe the matrix obtained by applying $R_3 \rightarrow 4R_1 + R_3$ and then $R_1 \rightarrow -4R_1$ to A (note the order).

Solution.

$$1. P = \begin{bmatrix} 1 & 0 & 0 & 0 \\ 0 & 1 & 0 & 0 \\ 4 & 0 & 1 & 0 \\ 0 & 0 & 0 & 1 \end{bmatrix}$$

$$2. Q = \begin{bmatrix} -4 & 0 & 0 & 0 \\ 0 & 1 & 0 & 0 \\ 0 & 0 & 1 & 0 \\ 0 & 0 & 0 & 1 \end{bmatrix}$$

3. QPA

□

Let A be a 4×4 matrix with determinant -7 .

1. Let B be the matrix obtained from A by applying the row operation $R_3 + 3R_4 \rightarrow R_3$. What is $\det(B)$?
2. Let C be the matrix obtained from A by applying the row operation $-3R_2 \rightarrow R_2$. What is $\det(C)$?
3. Let D be the matrix obtained from A by applying the row operation $R_3 \leftrightarrow R_4$. What is $\det(D)$?

Solution.

1. Adding a multiple of one row to another row does not change the determinant, so $\det(B) = \det(A) = -7$.
2. Scaling a row scales the determinant by the same factor, so $\det(B) = -3 \det(A) = -3(-7) = 21$.
3. Swapping rows changes the sign of the determinant, so $\det(B) = -\det(A) = 7$.

□

Show how to compute the determinant of the matrix

$$A = \begin{bmatrix} 1 & 3 & 0 & -1 \\ 1 & 1 & 2 & 4 \\ 1 & 1 & 1 & 3 \\ -3 & 1 & 2 & -5 \end{bmatrix}$$

Solution. Here is one possible solution, first applying a single row operation, and then performing Laplace/cofactor expansions to reduce the determinant to a linear combination of 2×2 determinants:

$$\begin{aligned} \det \begin{bmatrix} 1 & 3 & 0 & -1 \\ 1 & 1 & 2 & 4 \\ 1 & 1 & 1 & 3 \\ -3 & 1 & 2 & -5 \end{bmatrix} &= \det \begin{bmatrix} 1 & 3 & 0 & -1 \\ 0 & 0 & 1 & 1 \\ 1 & 1 & 1 & 3 \\ -3 & 1 & 2 & -5 \end{bmatrix} = (-1) \det \begin{bmatrix} 1 & 3 & -1 \\ 1 & 1 & 3 \\ -3 & 1 & -5 \end{bmatrix} + (1) \det \begin{bmatrix} 1 & 3 & 0 \\ 1 & 1 & 1 \\ -3 & 1 & 2 \end{bmatrix} \\ &= (-1) \left((1) \det \begin{bmatrix} 1 & 3 \\ 1 & -5 \end{bmatrix} - (1) \det \begin{bmatrix} 3 & -1 \\ 1 & -5 \end{bmatrix} + (-3) \det \begin{bmatrix} 3 & -1 \\ 1 & 3 \end{bmatrix} \right) + \\ &\quad (1) \left((1) \det \begin{bmatrix} 1 & 1 \\ 1 & 2 \end{bmatrix} - (3) \det \begin{bmatrix} 1 & 1 \\ -3 & 2 \end{bmatrix} \right) \\ &= (-1)(-8 + 14 - 30) + (1)(1 - 15) \\ &= 10 \end{aligned}$$

Here is another possible solution, using row and column operations to first reduce the determinant to a 3×3 matrix and then applying a formula:

$$\begin{aligned} \det \begin{bmatrix} 1 & 3 & 0 & -1 \\ 1 & 1 & 2 & 4 \\ 1 & 1 & 1 & 3 \\ -3 & 1 & 2 & -5 \end{bmatrix} &= \det \begin{bmatrix} 1 & 3 & 0 & -1 \\ 0 & 0 & 1 & 1 \\ 1 & 1 & 1 & 3 \\ -3 & 1 & 2 & -5 \end{bmatrix} = \det \begin{bmatrix} 1 & 3 & 0 & -1 \\ 0 & 0 & 1 & 0 \\ 1 & 1 & 1 & 2 \\ -3 & 1 & 2 & -7 \end{bmatrix} \\ &= -\det \begin{bmatrix} 1 & 3 & 0 & -1 \\ 1 & 1 & 1 & 2 \\ 0 & 0 & 1 & 0 \\ -3 & 1 & 2 & -7 \end{bmatrix} = -\det \begin{bmatrix} 1 & 3 & -1 \\ 1 & 1 & 2 \\ -3 & 1 & -7 \end{bmatrix} \\ &= -((-7 - 18 - 1) - (3 + 2 - 21)) \\ &= 10 \end{aligned}$$

□

Explain how to find the eigenvalues of the matrix $\begin{bmatrix} -2 & -2 \\ 10 & 7 \end{bmatrix}$.

Solution. Compute the characteristic polynomial:

$$\begin{aligned} \det(A - \lambda I) &= \det \begin{bmatrix} -2 - \lambda & -2 \\ 10 & 7 - \lambda \end{bmatrix} \\ &= (-2 - \lambda)(7 - \lambda) + 20 = \lambda^2 - 5\lambda + 6 = (\lambda - 2)(\lambda - 3) \end{aligned}$$

The eigenvalues are the roots of the characteristic polynomial, namely 2 and 3. □

Explain how to find a basis for the eigenspace associated to the eigenvalue 3 in the matrix

$$\begin{bmatrix} -7 & -8 & 2 \\ 8 & 9 & -1 \\ \frac{13}{2} & 5 & 2 \end{bmatrix}.$$

Solution. The eigenspace associated to 3 is the kernel of $A - 3I$, so we compute

$$\begin{aligned} \text{RREF}(A - 3I) &= \text{RREF} \begin{bmatrix} -7 - 3 & -8 & 2 \\ 8 & 9 - 3 & -1 \\ \frac{13}{2} & 5 & 2 - 3 \end{bmatrix} = \\ &= \text{RREF} \begin{bmatrix} -10 & -8 & 2 \\ 8 & 6 & -1 \\ \frac{13}{2} & 5 & -1 \end{bmatrix} = \begin{bmatrix} 1 & 0 & 1 \\ 0 & 1 & -\frac{3}{2} \\ 0 & 0 & 0 \end{bmatrix}. \end{aligned}$$

Thus we see the kernel is

$$\left\{ \left[\begin{array}{c} -a \\ \frac{3}{2}a \\ a \end{array} \right] \mid a \in \mathbb{R} \right\}$$

which has a basis of $\left\{ \left[\begin{array}{c} -1 \\ \frac{3}{2} \\ 1 \end{array} \right] \right\}$.

□

B.2 Definitions

Section 1.1 Linear Systems, Vector Equations, and Augmented Matrices (LE1)

[Definition 1.1.2](#)

[Definition 1.1.3](#)

[Definition 1.1.5](#)

[Definition 1.1.7](#)

[Definition 1.1.10](#)

[Definition 1.1.17](#)

Section 1.2 Row Reduction of Matrices (LE2)

[Definition 1.2.2](#)

[Definition 1.2.5](#)

[Definition 1.2.8](#)

Section 1.4 Linear Systems with Infinitely-Many Solutions (LE4)

[Definition 1.4.3](#)

Section 2.1 Linear Combinations (EV1)

[Definition 2.1.3](#)

[Definition 2.1.4](#)

Section 2.3 Subspaces (EV3)

[Definition 2.3.4](#)

[Definition 2.3.7](#)

Section 2.4 Linear Independence (EV4)

[Definition 2.4.3](#)

Section 2.5 Identifying a Basis (EV5)

[Definition 2.5.5](#)

(Continued on next page)

[Definition 2.5.9](#)

Section 2.6 Subspace Basis and Dimension (EV6)

[Definition 2.6.4](#)

[Definition 2.6.9](#)

Section 3.1 Linear Transformations (AT1)

[Definition 3.1.3](#)

[Definition 3.1.4](#)

Section 3.2 Standard Matrices (AT2)

[Definition 3.2.8](#)

Section 3.3 Image and Kernel (AT3)

[Definition 3.3.3](#)

[Definition 3.3.8](#)

Section 3.4 Injective and Surjective Linear Maps (AT4)

[Definition 3.4.2](#)

[Definition 3.4.5](#)

[Definition 3.4.12](#)

Section 3.5 Vector Spaces (AT5)

[Definition 3.5.7](#)

Section 4.1 Matrices and Multiplication (MX1)

[Definition 4.1.4](#)

Section 4.2 The Inverse of a Matrix (MX2)

[Definition 4.2.3](#)

[Definition 4.2.6](#)

Section 5.1 Row Operations and Determinants (GT1)

[Definition 5.1.11](#)

Section 5.3 Eigenvalues and Characteristic Polynomials (GT3)

(Continued on next page)

[Definition 5.3.5](#)

[Definition 5.3.8](#)

Section 5.4 Eigenvectors and Eigenspaces (GT4)

[Definition 5.4.3](#)

Section A.1 Civil Engineering: Trusses and Struts

[Definition A.1.1](#)

Section A.3 Geology: Phases and Components

[Definition A.3.1](#)

Index

- additive identity, 107
- additive inverse, 107
- augmented matrix, 6
- basis, 58, 59
- bound variables, 24
- closed under addition, 44
- closed under scalar multiplication, 44
- coefficient matrix, 7
- column space, 115
- determine, 82
- dot product, 85
- eigenspace, 163
- eigenvalue, 160
- eigenvector, 159, 160
- equivalence relation, 9
- equivalent matrices, 10
- Euclidean
 - vector space, 30
- Euclidean vector, 3
- free variables, 24
- Gauss-Jordan elimination, 14
- homogeneous, 42, 67
- identity matrix, 61
- inverse map, 124
- inverse matrix, 124
- invertible, 124
- isomorphic, 44, 113
- isomorphism, 113
- kernel, 87
- linear combination, 31
- linear equation, 3
 - solution, 4
- linear system, 4
 - consistent, 5
 - inconsistent, 5
- linear transformation, 74
- linearly dependent, 52
- linearly independent, 52
- matrix, 2
- non-singular, 71
- nontrivial, 160
- pivot, 13
- rank, 115
- Reduced row echelon form, 13
- row operations, 12
- row space, 115
- scalar, 106
- solution set, 4
- span, 31
- standard, 59
- standard matrix, 82
- subspace, 44
- symmetric matrix, 50
- system of linear equations, 4
- vector, 106
 - Euclidean, 3
- vector equation, 4
- vector space, 44, 106